

GENERAL DESCRIPTION

The SGM835 has a wide input common-mode voltage range from -0.3V to 72V, and is available with gains of 12.5V/V, 20V/V and 50V/V. The bandwidth of small-signal can reach up to 160kHz.

The SGM835 is available in a Green MSOP-8 package. It is specified over a junction temperature range of -40°C to +125°C.

APPLICATIONS

- Communication Equipment
- Servers
- Battery Chargers
- Industrial Control
- Automation Equipment
- Energy Management

FEATURES

- **Input Common-Mode Voltage Range: -0.3V to 72V**
- **Low Input Offset Voltage: 125μV (MAX)**
- **Gain: 12.5V/V, 20V/V or 50V/V**
- **Low Gain Error: 0.2% (MAX)**
- **Available in a Green MSOP-8 Package**

TYPICAL APPLICATION

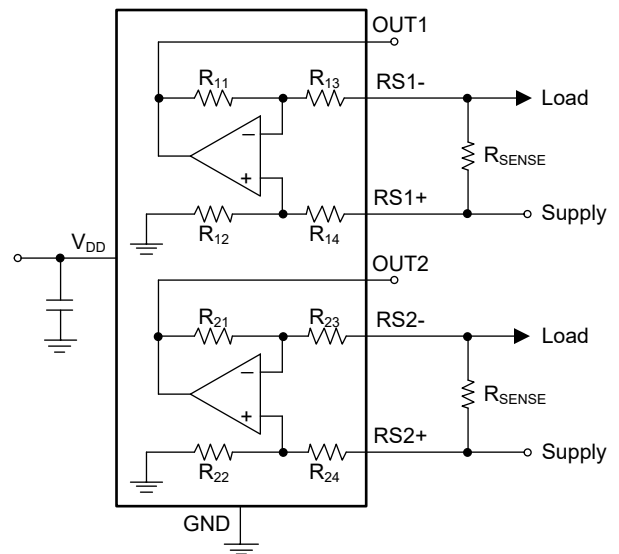

Figure 1. Simplified Typical Application Circuit

PACKAGE/ORDERING INFORMATION

MODEL	PACKAGE DESCRIPTION	SPECIFIED TEMPERATURE RANGE	GAIN (V/V)	ORDERING NUMBER	PACKAGE MARKING	PACKING OPTION
SGM835L	MSOP-8	-40°C to +125°C	12.5	SGM835LXMS8G/TR	0EO XMS8 XXXXX	Tape and Reel, 4000
SGM835T	MSOP-8	-40°C to +125°C	20	SGM835TXMS8G/TR	0EM XMS8 XXXXX	Tape and Reel, 4000
SGM835F	MSOP-8	-40°C to +125°C	50	SGM835FXMS8G/TR	0EN XMS8 XXXXX	Tape and Reel, 4000

MARKING INFORMATION

NOTE: XXXXX = Date Code.

XXXXX

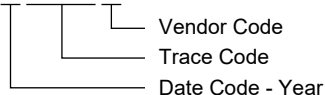

Green (RoHS & HSF): SG Micro Corp defines "Green" to mean Pb-Free (RoHS compatible) and free of halogen substances. If you have additional comments or questions, please contact your SGMICRO representative directly.

ABSOLUTE MAXIMUM RATINGS

V _{DD} to GND	-0.3V to 6V
RSX+, RSX- to GND	-0.3V to 76V
RSX+ to RSX-	±76V
Continuous Input Current at Any Pin	±20mA
Package Thermal Resistance	
MSOP-8, θ _{JA}	158°C/W
Junction Temperature	+150°C
Storage Temperature Range	-65°C to +150°C
Lead Temperature (Soldering, 10s)	+260°C
ESD Susceptibility	
HBM	4000V
CDM	1000V

RECOMMENDED OPERATING CONDITIONS

Supply Voltage Range	2.7V to 5.5V
Operating Junction Temperature Range	-40°C to +125°C

OVERSTRESS CAUTION

Stresses beyond those listed in Absolute Maximum Ratings may cause permanent damage to the device. Exposure to absolute maximum rating conditions for extended periods may affect reliability. Functional operation of the device at any conditions beyond those indicated in the Recommended Operating Conditions section is not implied.

ESD SENSITIVITY CAUTION

This integrated circuit can be damaged if ESD protections are not considered carefully. SGMICRO recommends that all integrated circuits be handled with appropriate precautions. Failure to observe proper handling and installation procedures can cause damage. ESD damage can range from subtle performance degradation to complete device failure. Precision integrated circuits may be more susceptible to damage because even small parametric changes could cause the device not to meet the published specifications.

DISCLAIMER

SG Micro Corp reserves the right to make any change in circuit design, or specifications without prior notice.

PIN CONFIGURATIONS

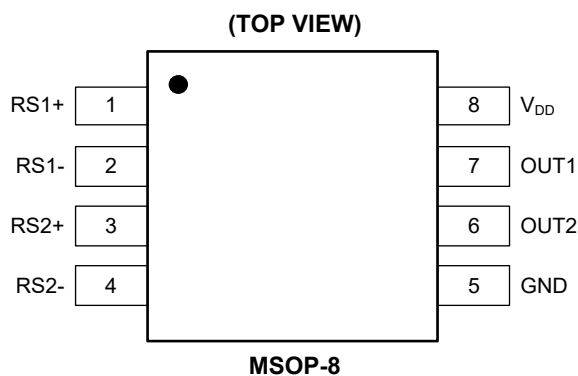

PIN DESCRIPTION

PIN	NAME	FUNCTION
1	RS1+	Power-Side Connection Pin. Channel 1.
2	RS1-	Load-Side Connection Pin. Channel 1.
3	RS2+	Power-Side Connection Pin. Channel 2.
4	RS2-	Load-Side Connection Pin. Channel 2.
5	GND	Ground.
6	OUT2	Output Pin. Channel 2.
7	OUT1	Output Pin. Channel 1.
8	V _{DD}	Supply Voltage Pin.

PACKAGE OUTLINE DIMENSIONS

MSOP-8

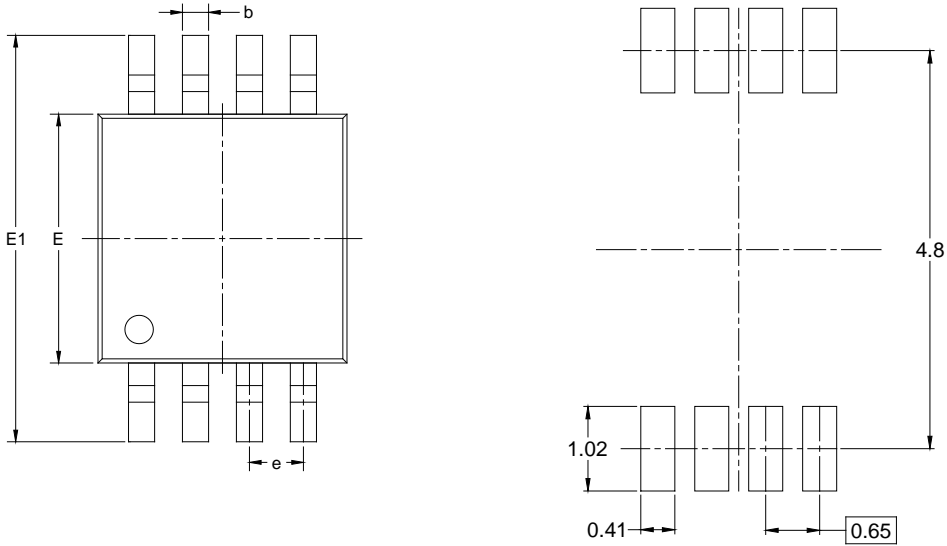

RECOMMENDED LAND PATTERN (Unit: mm)

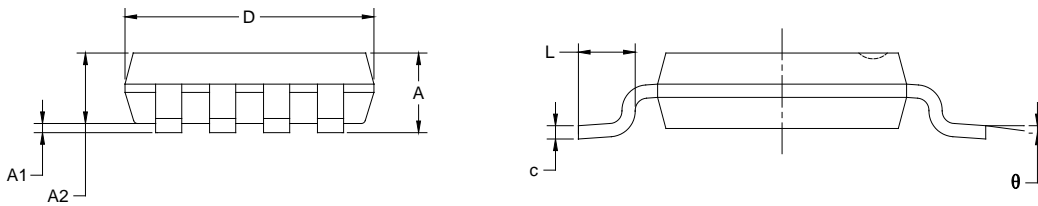

Symbol	Dimensions In Millimeters		Dimensions In Inches	
	MIN	MAX	MIN	MAX
A	0.820	1.100	0.032	0.043
A1	0.020	0.150	0.001	0.006
A2	0.750	0.950	0.030	0.037
b	0.250	0.380	0.010	0.015
c	0.090	0.230	0.004	0.009
D	2.900	3.100	0.114	0.122
E	2.900	3.100	0.114	0.122
E1	4.750	5.050	0.187	0.199
e	0.650 BSC		0.026 BSC	
L	0.400	0.800	0.016	0.031
θ	0°	6°	0°	6°

NOTES:

1. Body dimensions do not include mode flash or protrusion.
2. This drawing is subject to change without notice.

PACKAGE INFORMATION

TAPE AND REEL INFORMATION

REEL DIMENSIONS



TAPE DIMENSIONS



NOTE: The picture is only for reference. Please make the object as the standard.

KEY PARAMETER LIST OF TAPE AND REEL

Package Type	Reel Diameter	Reel Width W1 (mm)	A0 (mm)	B0 (mm)	K0 (mm)	P0 (mm)	P1 (mm)	P2 (mm)	W (mm)	Pin1 Quadrant
MSOP-8	13"	12.4	5.20	3.30	1.50	4.0	8.0	2.0	12.0	Q1

DD0001

PACKAGE INFORMATION

CARTON BOX DIMENSIONS



NOTE: The picture is only for reference. Please make the object as the standard.

KEY PARAMETER LIST OF CARTON BOX

Reel Type	Length (mm)	Width (mm)	Height (mm)	Pizza/Carton
13"	386	280	370	5

DD0002