

GENERAL DESCRIPTION

The SGMPM21330 is a power MOSFET with a low on-state resistance and low gate charge. This feature makes it a good choice for a load switch application.

FEATURES

- Low On-State Resistance
- High-Speed Switching
- Halogen-Free/RoHS Compliant

APPLICATIONS

Load Switch Applications
 High-Speed Line Driver
 Relay Driver Applications
 Handheld and Mobile Applications
 USB Connector VBUS Power Switch

ABSOLUTE MAXIMUM RATINGS

PARAMETER	SYMBOL	VALUE	UNITS
Drain-to-Source Voltage	V_{DS}	-30	V
Gate-to-Source Voltage	V_{GS}	± 20	V
Continuous Drain Current (DC)	I_D	-7.5	A
Continuous Drain Current (Pulse)	I_D	-30	A
Total Dissipation	P_D	2	W
Avalanche Current ⁽¹⁾	I_{AS}	-37.1	A
Avalanche Energy ⁽¹⁾	E_{AS}	68.8	mJ
Junction Temperature	T_J	+150	$^{\circ}C$
Storage Temperature Range	T_{STG}	-55 to +150	$^{\circ}C$
Lead Temperature (Soldering, 10s)		+260	$^{\circ}C$

Stresses beyond those listed in Absolute Maximum Ratings may cause permanent damage to the device. Exposure to absolute maximum rating conditions for extended periods may affect reliability.

NOTE: 1. Parts are 100% tested at $V_{GS} = -10V$, $I_L = -26A$, and $E_{AS} = 33.8mJ$.

PRODUCT SUMMARY

$R_{DS(on)}$ (TYP) $V_{GS} = -10V$	$R_{DS(on)}$ (MAX) $V_{GS} = -10V$	I_D (MAX) $T_A = +25^{\circ}C$
16.7m Ω	21.7m Ω	-7.5A

PIN CONFIGURATIONS

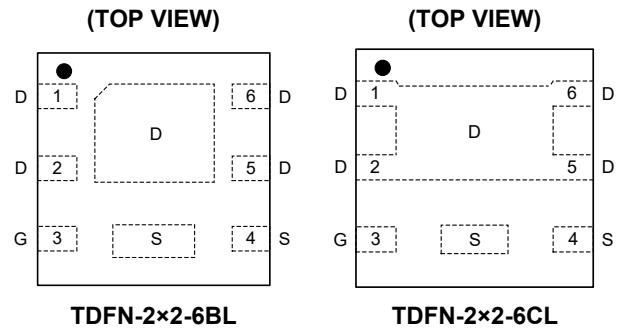

EQUIVALENT CIRCUIT

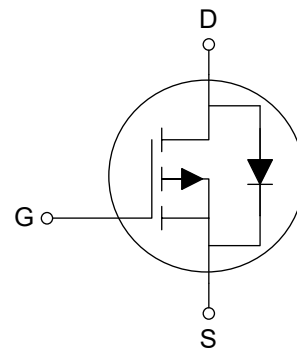

PACKAGE/ORDERING INFORMATION

MODEL	PACKAGE DESCRIPTION	SPECIFIED TEMPERATURE RANGE	ORDERING NUMBER	PACKAGE MARKING	PACKING OPTION
SGMPM21330	TDFN-2x2-6BL	-55°C to +150°C	SGMPM21330TTEN6G/TR	MEL XXXX	Tape and Reel, 3000
	TDFN-2x2-6CL	-55°C to +150°C	SGMPM21330TTEO6G/TR	MEM XXXX	Tape and Reel, 3000

MARKING INFORMATION

NOTE: XXXX = Date Code, Trace Code and Vendor Code.

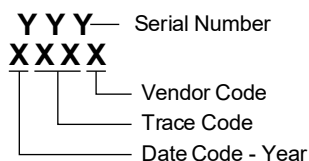

Green (RoHS & HSF): SG Micro Corp defines "Green" to mean Pb-Free (RoHS compatible) and free of halogen substances. If you have additional comments or questions, please contact your SGMICRO representative directly.

DISCLAIMER

SG Micro Corp reserves the right to make any change in circuit design, or specifications without prior notice.

THERMAL RESISTANCE MAXIMUM RATINGS

PARAMETER	SYMBOL	VALUE	UNITS
Junction-to-Ambient Thermal Resistance	R _{θJA}	62.5	°C/W

ELECTRICAL CHARACTERISTICS(T_A = +25°C, unless otherwise noted.)

PARAMETER	SYMBOL	CONDITIONS	MIN	TYP	MAX	UNITS
Static Off Characteristics						
Drain-to-Source Breakdown Voltage	V _{BR_DSS}	V _{GS} = 0V, I _D = -250μA	-30			V
Zero Gate Voltage Drain Current	I _{DSS}	V _{GS} = 0V, V _{DS} = -30V			-1	μA
Gate-to-Source Leakage Current	I _{GSS}	V _{GS} = ±20V, V _{DS} = 0V			±100	nA
Static On Characteristics						
Gate Threshold Voltage	V _{GS_TH}	V _{GS} = V _{DS} , I _D = -250μA	-1		-2.5	V
Static Drain-to-Source On-State Resistance	R _{DSON}	V _{GS} = -10V, I _D = -7.5A		16	21	mΩ
		V _{GS} = -4.5V, I _D = -7.5A		24	31	
Forward Transconductance	g _{FS}	V _{DS} = -5V, I _D = -7.5A		17.5		S
Diode Characteristics						
Diode Forward Voltage	V _{F_SD}	V _{GS} = 0V, I _S = -1A		-0.7	-1.2	V
Dynamic Characteristics						
Input Capacitance	C _{ISS}	V _{GS} = 0V, V _{DS} = -15V, f = 1MHz		1791		pF
Output Capacitance	C _{OSS}			194		
Reverse Transfer Capacitance	C _{RSS}			156		
Total Gate Charge	Q _G	V _{DS} = -15V, I _D = -7.5A	V _{GS} = -10V	32		nC
			V _{GS} = -4.5V	15		
Gate-to-Source Charge	Q _{GS}	V _{GS} = -4.5V, V _{DS} = -15V, I _D = -7.5A		7.2		nC
Gate-to-Drain Charge	Q _{GD}			5		
Switch Characteristics						
Turn-On Delay Time	t _{D_ON}	V _{GS} = -10V, V _{DS} = -15V, I _D = -3.75A, R _G = 3Ω		8.6		ns
Rise Time	t _R			16.8		
Turn-Off Delay Time	t _{D_OFF}			37		
Fall Time	t _F			28.8		

TYPICAL PERFORMANCE CHARACTERISTICS

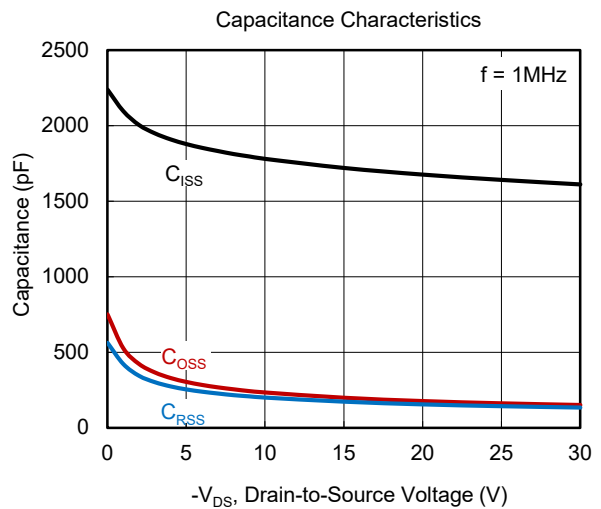
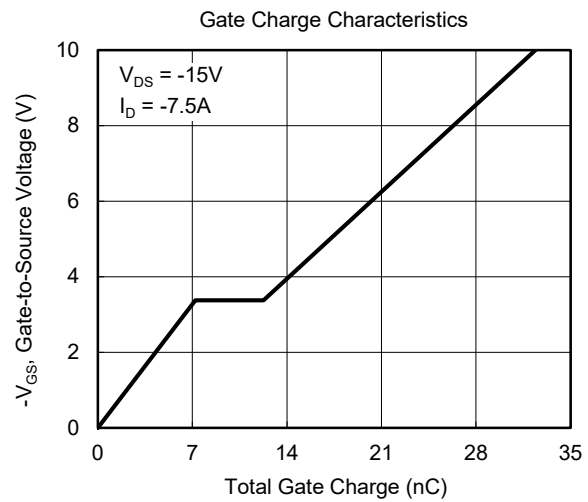
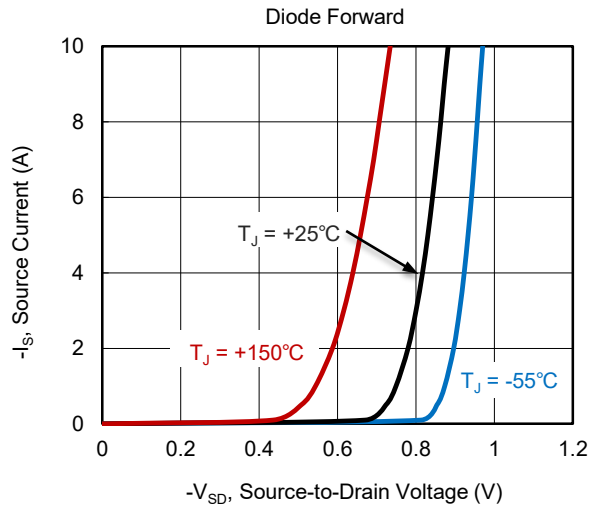
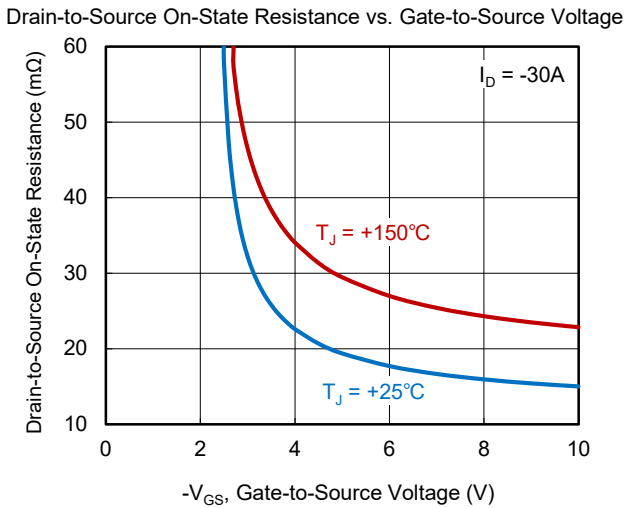
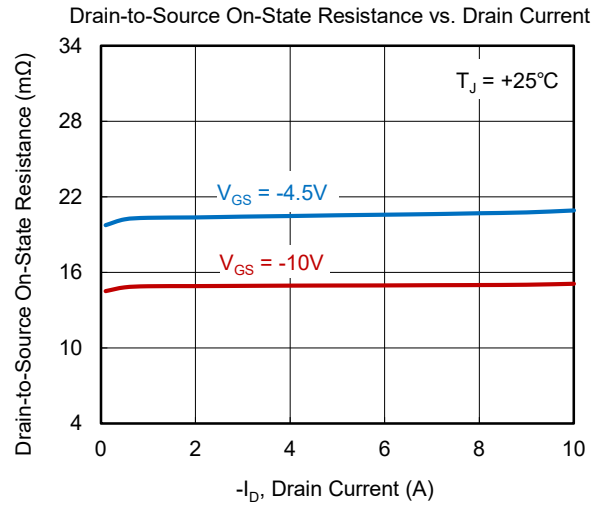
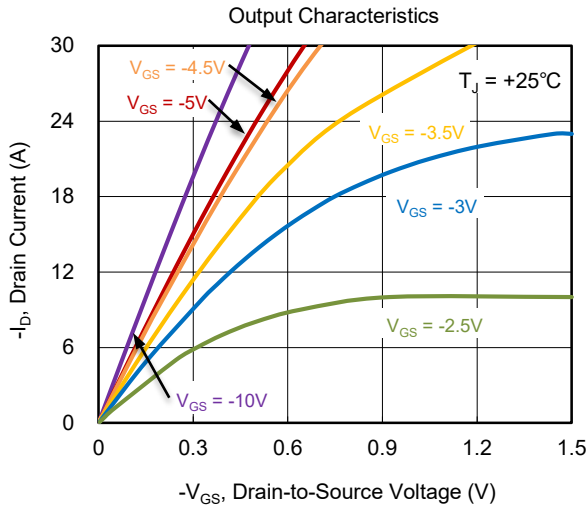

TYPICAL PERFORMANCE CHARACTERISTICS (continued)

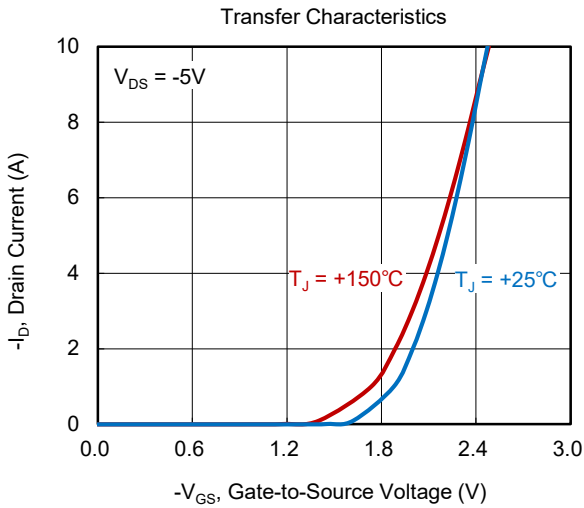
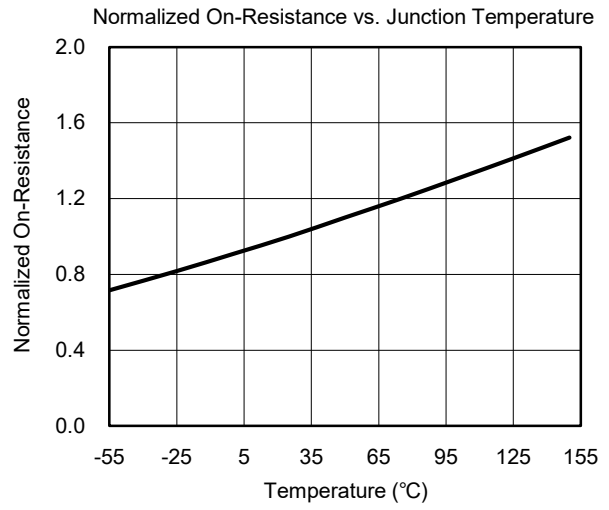
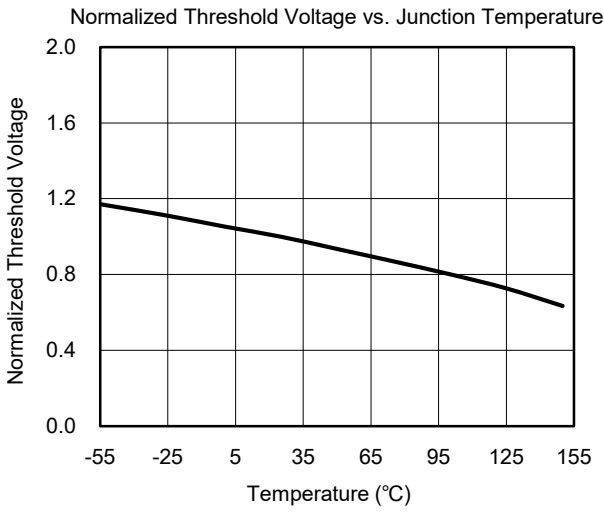

REVISION HISTORY

NOTE: Page numbers for previous revisions may differ from page numbers in the current version.

JANUARY 2024 – REV.A to REV.A.1		Page
Updated product summary and diode forward curve	1, 4
Changes from Original (OCTOBER 2023) to REV.A		Page
Changed from Product Preview to Production Data	All

PACKAGE OUTLINE DIMENSIONS

TDFN-2x2-6BL

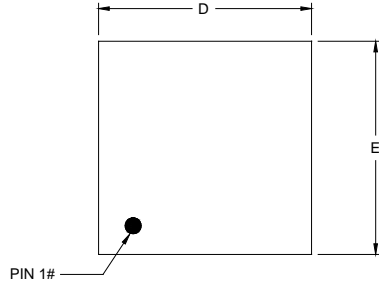

TOP VIEW

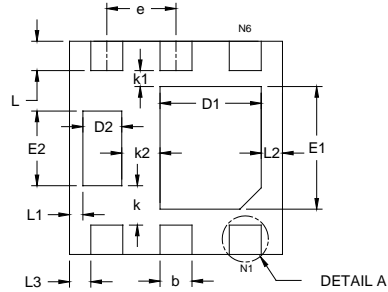

BOTTOM VIEW

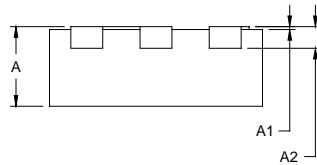

SIDE VIEW

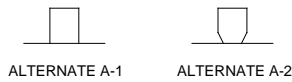

DETAIL A

ALTERNATE TERMINAL CONSTRUCTION

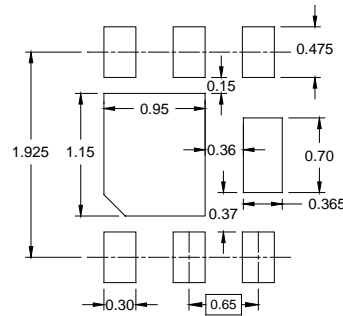

RECOMMENDED LAND PATTERN (Unit: mm)

Symbol	Dimensions In Millimeters		
	MIN	MOD	MAX
A	0.700	0.750	0.800
A1	0.000	0.020	0.050
A2	0.200 REF		
b	0.250	0.300	0.350
D	1.900	2.000	2.100
E	1.900	2.000	2.100
D1	0.850	0.950	1.050
E1	1.050	1.150	1.250
D2	0.315	0.365	0.415
E2	0.650	0.700	0.750
e	0.650 BSC		
k	0.370 REF		
k1	0.150 REF		
k2	0.360 REF		
L	0.225	0.275	0.325
L1	0.125 REF		
L2	0.200 REF		
L3	0.200 REF		

NOTE: This drawing is subject to change without notice.

PACKAGE OUTLINE DIMENSIONS

TDFN-2x2-6CL

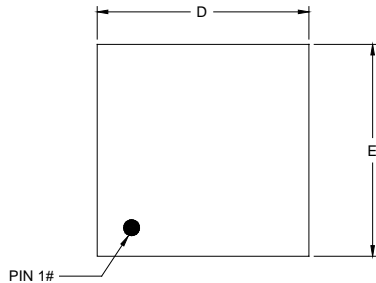

TOP VIEW

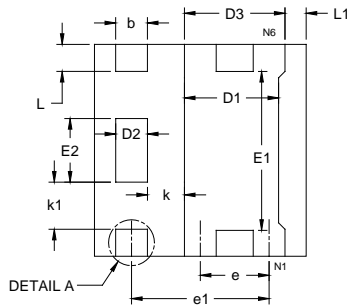

BOTTOM VIEW

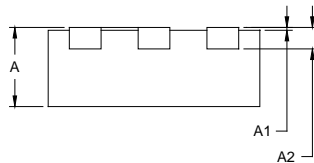

SIDE VIEW

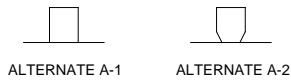

DETAIL A

ALTERNATE TERMINAL CONSTRUCTION

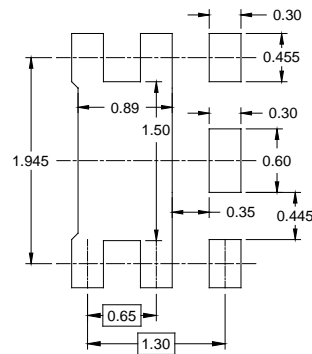

RECOMMENDED LAND PATTERN (Unit: mm)

Symbol	Dimensions In Millimeters		
	MIN	MOD	MAX
A	0.700	0.750	0.800
A1	0.000	0.020	0.050
A2	0.200 REF		
b	0.250	0.300	0.350
D	1.900	2.000	2.100
E	1.900	2.000	2.100
D1	0.790	0.890	0.990
E1	1.400	1.500	1.600
D2	0.200	0.300	0.400
E2	0.500	0.600	0.700
D3	0.950 REF		
e	0.650 BSC		
e1	1.300 BSC		
k	0.350 REF		
k1	0.445 REF		
L	0.180	0.255	0.355
L1	0.200 REF		

NOTE: This drawing is subject to change without notice.

TAPE AND REEL INFORMATION

REEL DIMENSIONS

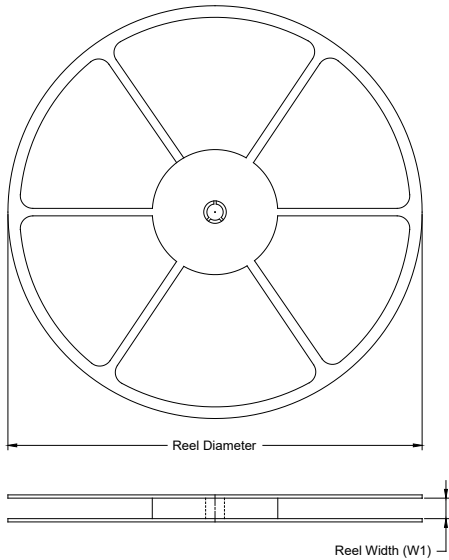

TAPE DIMENSIONS

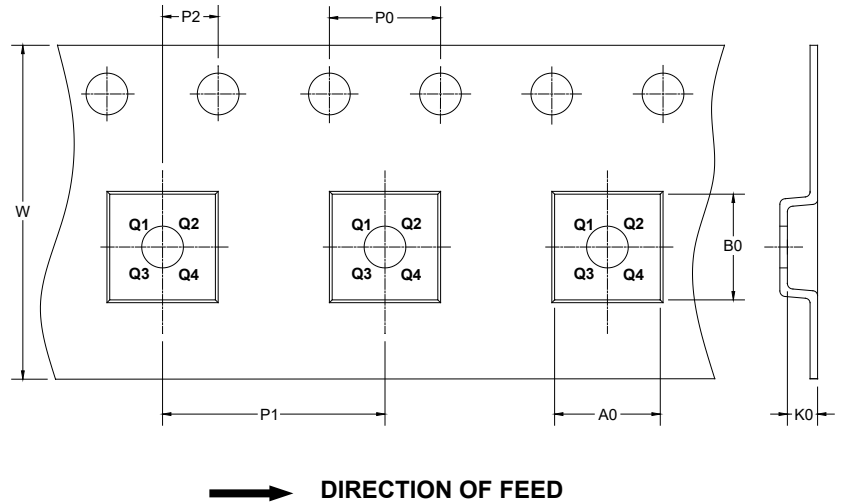

NOTE: The picture is only for reference. Please make the object as the standard.

KEY PARAMETER LIST OF TAPE AND REEL

Package Type	Reel Diameter	Reel Width W1 (mm)	A0 (mm)	B0 (mm)	K0 (mm)	P0 (mm)	P1 (mm)	P2 (mm)	W (mm)	Pin1 Quadrant
TDFN-2×2-6BL	7"	9.5	2.30	2.30	1.00	4.0	4.0	2.0	8.0	Q1
TDFN-2×2-6CL	7"	9.5	2.30	2.30	1.00	4.0	4.0	2.0	8.0	Q1

D20001

PACKAGE INFORMATION

CARTON BOX DIMENSIONS



NOTE: The picture is only for reference. Please make the object as the standard.

KEY PARAMETER LIST OF CARTON BOX

Reel Type	Length (mm)	Width (mm)	Height (mm)	Pizza/Carton
7" (Option)	368	227	224	8
7"	442	410	224	18

DD0002