

### GENERAL DESCRIPTION

The SGM4581 is an 8-channel, TTL/CMOS compatible analog multiplexer. It operates from +3.6V to +11V single power supply or  $\pm 1.8V$  to  $\pm 5.5V$  dual power supplies.

The SGM4581 features high voltage, low on-resistance and low distortion. The high performances make it very suitable for multiple applications, such as cellular phones, audio and video signal routing, etc.

TTL/CMOS logic compatibility can be guaranteed when using a single +5V or dual  $\pm 5V$  power supplies because the logic thresholds of all digital inputs are between 0.8V and 2.4V.

The SGM4581 is available in Green SOIC-16, SSOP-16, TSSOP-16 and TQFN-3 $\times$ 3-16L packages. It operates over an ambient temperature range of -40°C to +85°C.

### FEATURES

- **Single Supply Voltage Range: +3.6V to +11V**
- **Dual-Supply Voltage Range:  $\pm 1.8V$  to  $\pm 5.5V$**
- **High Off-Isolation: -70dB ( $R_L = 50\Omega$ ,  $f = 1MHz$ )**
- **On-Resistance:**
  - 51 $\Omega$  (MAX) with  $\pm 5V$  Supplies**
  - 84 $\Omega$  (MAX) with Single +5V Supply**
- **Low On-Resistance Flatness**
- **Low Off-Leakage Current: 10nA (TYP) at +25°C**
- **Low On-Leakage Current: 10nA (TYP) at +25°C**
- **Low Distortion: 0.08% ( $R_L = 600\Omega$ ,  $f = 20Hz$  to 20kHz)**
- **Rail-to-Rail Input and Output Operation**
- **TTL/CMOS-Logic Compatible**
- **-40°C to +85°C Operating Temperature Range**
- **Available in Green SOIC-16, SSOP-16, TSSOP-16 and TQFN-3 $\times$ 3-16L Packages**

### APPLICATIONS

Automotive  
Cellular Phones  
Portable Equipment  
Sample-and-Hold Circuits  
Battery-Powered Systems  
Audio and Video Signal Routing

**PACKAGE/ORDERING INFORMATION**

MODEL	PACKAGE DESCRIPTION	SPECIFIED TEMPERATURE RANGE	ORDERING NUMBER	PACKAGE MARKING	PACKING OPTION
SGM4581	SOIC-16	-40°C to +85°C	SGM4581YS16G/TR	SGM4581YS16 XXXXX	Tape and Reel, 2500
	SSOP-16	-40°C to +85°C	SGM4581YQS16G/TR	SGM4581 YQS16 XXXXX	Tape and Reel, 3000
	TSSOP-16	-40°C to +85°C	SGM4581YTS16G/TR	SGM4581 YTS16 XXXXX	Tape and Reel, 3000
	TQFN-3×3-16L	-40°C to +85°C	SGM4581YTQ16G/TR	4581TQ XXXXX	Tape and Reel, 3000

**MARKING INFORMATION**

NOTE: XXXXX = Date Code and Vendor Code.

**SOIC-16/SSOP-16/TSSOP-16/TQFN-3×3-16L**

**XXXXX**

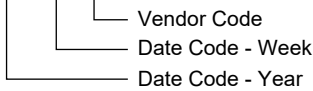

Green (RoHS & HSF): SG Micro Corp defines "Green" to mean Pb-Free (RoHS compatible) and free of halogen substances. If you have additional comments or questions, please contact your SGMICRO representative directly.

**ABSOLUTE MAXIMUM RATINGS**

- Voltages Referenced to V<sub>EE</sub>
- V<sub>CC</sub> ..... -0.3V to 13.2V
- GND ..... -0.3V to 6V
- Voltage into Any Terminal <sup>(1)</sup>  
..... (V<sub>EE</sub> - 0.3V) to (V<sub>CC</sub> + 0.3V)
- Continuous Current into Any Terminal..... ±20mA
- Peak Current, X<sub>-</sub> (pulsed at 1ms, 10% duty cycle)  
..... ±40mA
- Junction Temperature..... +150°C
- Storage Temperature Range..... -65°C to +150°C
- Lead Temperature (Soldering, 10s)..... +260°C
- ESD Susceptibility
- HBM..... 3000V
- MM..... 200V

NOTE: 1. Voltages exceeding V<sub>CC</sub> or V<sub>EE</sub> on any signal terminal are clamped by internal diodes. Limit forward-diode current to maximum current rating.

**RECOMMENDED OPERATING CONDITIONS**

- Operating Temperature Range..... -40°C to +85°C

**OVERSTRESS CAUTION**

Stresses beyond those listed in Absolute Maximum Ratings may cause permanent damage to the device. Exposure to absolute maximum rating conditions for extended periods may affect reliability. Functional operation of the device at any conditions beyond those indicated in the Recommended Operating Conditions section is not implied.

**ESD SENSITIVITY CAUTION**

This integrated circuit can be damaged if ESD protections are not considered carefully. SGMICRO recommends that all integrated circuits be handled with appropriate precautions. Failure to observe proper handling and installation procedures can cause damage. ESD damage can range from subtle performance degradation to complete device failure. Precision integrated circuits may be more susceptible to damage because even small parametric changes could cause the device not to meet the published specifications.

**DISCLAIMER**

SG Micro Corp reserves the right to make any change in circuit design, or specifications without prior notice.

PIN CONFIGURATIONS

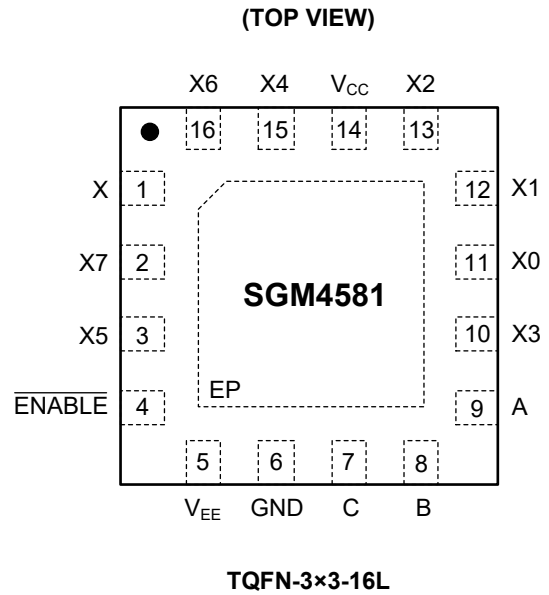
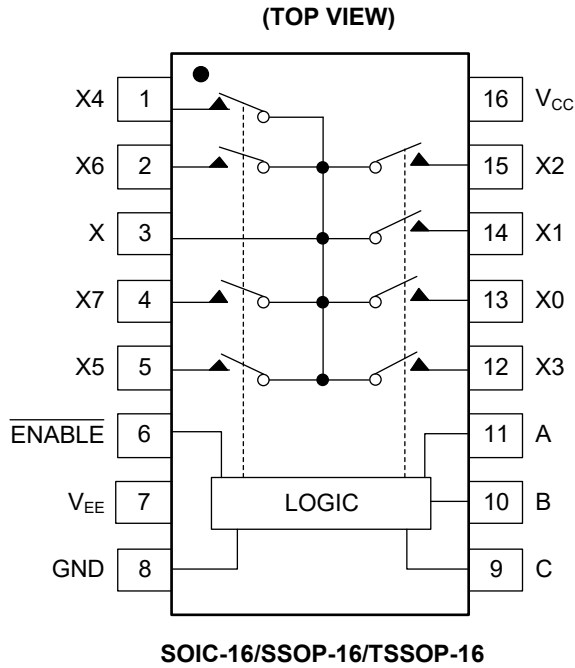

PIN DESCRIPTION

PIN		NAME	FUNCTION
SOIC-16, SSOP-16, TSSOP-16	TQFN-3x3-16L		
13, 14, 15, 12, 1, 5, 2, 4	11, 12, 13, 10, 15, 3, 16, 2	X0-X7	Analog Switch Input Pins.
3	1	X	Analog Switch Output Pin.
6	4	ENABLE	Digital Enable Control Pin. Normally connected to GND.
7	5	VEE	Negative Analog Supply Voltage Input Pin. Connect to GND for single-supply operation.
8	6	GND	Ground.
9	7	C	Digital Address "C" Input Pin.
10	8	B	Digital Address "B" Input Pin.
11	9	A	Digital Address "A" Input Pin.
16	14	VCC	Positive Analog and Digital Supply Voltage Input Pin.
—	Exposed Pad	EP	Exposed Pad. Connect exposed pad to VEE Pin.

NOTE:

Any input terminal can be used as an output terminal, and any output terminal can also be used as an input terminal. Signal transmission in both directions is equally well.

## FUNCTION TABLE

ENABLE INPUT	SELECT INPUTS			ON SWITCHES
	C	B	A	
H	X	X	X	All Switches Open
L	L	L	L	X-X0
L	L	L	H	X-X1
L	L	H	L	X-X2
L	L	H	H	X-X3
L	H	L	L	X-X4
L	H	L	H	X-X5
L	H	H	L	X-X6
L	H	H	H	X-X7

X = Don't care.

**ELECTRICAL CHARACTERISTICS (Dual Supplies)**(V<sub>CC</sub> = 4.5V to 5.5V, V<sub>EE</sub> = -4.5V to -5.5V, Full = -40°C to +85°C, typical values are at T<sub>A</sub> = +25°C, unless otherwise noted.)

PARAMETER	SYMBOL	CONDITIONS	TEMP	MIN	TYP	MAX	UNITS
<b>Analog Switch</b>							
Analog Signal Range	V <sub>X-</sub> , V <sub>X</sub>		Full	V <sub>EE</sub>		V <sub>CC</sub>	V
On-Resistance	R <sub>ON</sub>	V <sub>CC</sub> = 4.5V, V <sub>EE</sub> = -4.5V, I <sub>X</sub> = 1mA	+25°C		36	51	Ω
			Full			62	
On-Resistance Match Between Channels	ΔR <sub>ON</sub>	V <sub>CC</sub> = 4.5V, V <sub>EE</sub> = -4.5V, I <sub>X</sub> = 1mA	+25°C		3	11	Ω
			Full			12.7	
On-Resistance Flatness	R <sub>FLAT(ON)</sub>	V <sub>CC</sub> = 4.5V, V <sub>EE</sub> = -4.5V, I <sub>X</sub> = 1mA	+25°C		15	25	Ω
			Full			29	
X <sub>-</sub> Off Leakage Current	I <sub>X(OFF)</sub>	V <sub>CC</sub> = 5.5V, V <sub>EE</sub> = -5.5V, V <sub>X-</sub> = ±4.5V, V <sub>X</sub> = ∓4.5V	+25°C		10		nA
X Off Leakage Current	I <sub>X(OFF)</sub>	V <sub>CC</sub> = 5.5V, V <sub>EE</sub> = -5.5V, V <sub>X-</sub> = ±4.5V, V <sub>X</sub> = ∓4.5V	+25°C		10		nA
X On Leakage Current	I <sub>X(ON)</sub>	V <sub>CC</sub> = 5.5V, V <sub>EE</sub> = -5.5V, V <sub>X</sub> = ±4.5V	+25°C		10		nA
<b>Digital I/O</b>							
Logic Input Logic Threshold High	V <sub>AH</sub> , V <sub>BH</sub> , V <sub>CH</sub> , V <sub>ENABLEH</sub>		+25°C	2.4			V
Logic Input Logic Threshold Low	V <sub>AL</sub> , V <sub>BL</sub> , V <sub>CL</sub> , V <sub>ENABLEL</sub>		+25°C			0.8	V
Input-Current High	I <sub>AH</sub> , I <sub>BH</sub> , I <sub>CH</sub> , I <sub>ENABLEH</sub>	V <sub>A</sub> , V <sub>B</sub> , V <sub>C</sub> , V <sub>ENABLE</sub> = V <sub>CC</sub>	+25°C		10		nA
Input-Current Low	I <sub>AL</sub> , I <sub>BL</sub> , I <sub>CL</sub> , I <sub>ENABLEL</sub>	V <sub>A</sub> , V <sub>B</sub> , V <sub>C</sub> , V <sub>ENABLE</sub> = 0V	+25°C		10		nA
<b>Dynamic Characteristics</b>							
Address Transition Time	t <sub>TRANS</sub>	V <sub>X-</sub> = ±3V, R <sub>L</sub> = 300Ω, C <sub>L</sub> = 35pF, Test Circuit 1	+25°C		70		ns
ENABLE Turn-On Time	t <sub>ON</sub>	V <sub>X-</sub> = 3V, R <sub>L</sub> = 300Ω, C <sub>L</sub> = 35pF, Test Circuit 2	+25°C		60		ns
ENABLE Turn-Off Time	t <sub>OFF</sub>	V <sub>X-</sub> = 3V, R <sub>L</sub> = 300Ω, C <sub>L</sub> = 35pF, Test Circuit 2	+25°C		60		ns
Break-Before-Make Time Delay	t <sub>D</sub>	V <sub>X-</sub> = 3V, R <sub>L</sub> = 300Ω, C <sub>L</sub> = 35pF, Test Circuit 3	+25°C		20		ns
Charge Injection	Q	R <sub>S</sub> = 0Ω, C = 1nF, V <sub>S</sub> = 0V, Test Circuit 4	+25°C		15		pC
Off-Isolation	V <sub>ISO</sub>	R <sub>L</sub> = 50Ω, f = 1MHz, Test Circuit 5	+25°C		-70		dB
Input Off-Capacitance	C <sub>X(OFF)</sub>	V <sub>X-</sub> = 0V, f = 1MHz, Test Circuit 6	+25°C		9		pF
Output Off-Capacitance	C <sub>X(OFF)</sub>	V <sub>X-</sub> = 0V, f = 1MHz, Test Circuit 6	+25°C		40		pF
Output On-Capacitance	C <sub>X(ON)</sub>	V <sub>X-</sub> = 0V, f = 1MHz, Test Circuit 6	+25°C		60		pF
-3dB Bandwidth	BW	R <sub>L</sub> = 50Ω	+25°C		90		MHz
Total Harmonic Distortion	THD	R <sub>L</sub> = 600Ω, 5V <sub>P-P</sub> , f = 20Hz to 20kHz	+25°C		0.08		%
<b>Power Supply</b>							
Power Supply Range	V <sub>CC</sub> , V <sub>EE</sub>		Full	±1.8		±5.5	V
Power Supply Current	I <sub>CC</sub> , I <sub>EE</sub>	V <sub>CC</sub> = 5.5V, V <sub>EE</sub> = -5.5V, V <sub>A</sub> , V <sub>B</sub> , V <sub>C</sub> , V <sub>ENABLE</sub> = V <sub>CC</sub> or 0	+25°C		0.01	20	μA

**ELECTRICAL CHARACTERISTICS (Single Supply at +5V)**(V<sub>CC</sub> = 4.5V to 5.5V, V<sub>EE</sub> = 0V, Full = -40°C to +85°C, typical values are at T<sub>A</sub> = +25°C, unless otherwise noted.)

PARAMETER	SYMBOL	CONDITIONS	TEMP	MIN	TYP	MAX	UNITS
<b>Analog Switch</b>							
Analog Signal Range	V <sub>X-</sub> , V <sub>X</sub>		Full	V <sub>EE</sub>		V <sub>CC</sub>	V
On-Resistance	R <sub>ON</sub>	V <sub>CC</sub> = 4.5V, I <sub>X</sub> = 1mA	+25°C		66	84	Ω
			Full			97	
On-Resistance Match Between Channels	ΔR <sub>ON</sub>	V <sub>CC</sub> = 4.5V, I <sub>X</sub> = 1mA	+25°C		3	11	Ω
			Full			14	
X <sub>-</sub> Off Leakage Current	I <sub>X(OFF)</sub>	V <sub>CC</sub> = 5.5V, V <sub>X-</sub> = 1V, 4.5V, V <sub>X</sub> = 4.5V, 1V	+25°C		10		nA
X Off Leakage Current	I <sub>X(OFF)</sub>	V <sub>CC</sub> = 5.5V, V <sub>X-</sub> = 1V, 4.5V, V <sub>X</sub> = 4.5V, 1V	+25°C		10		nA
X On Leakage Current	I <sub>X(ON)</sub>	V <sub>CC</sub> = 5.5V, V <sub>X</sub> = 4.5V, 1V	+25°C		10		nA
<b>Digital I/O</b>							
Logic Input Logic Threshold High	V <sub>AH</sub> , V <sub>BH</sub> , V <sub>CH</sub> , V <sub>ENABLEH</sub>		+25°C	2.4			V
Logic Input Logic Threshold Low	V <sub>AL</sub> , V <sub>BL</sub> , V <sub>CL</sub> , V <sub>ENABLEL</sub>		+25°C			0.8	V
Input-Current High	I <sub>AH</sub> , I <sub>BH</sub> , I <sub>CH</sub> , I <sub>ENABLEH</sub>	V <sub>A</sub> , V <sub>B</sub> , V <sub>C</sub> , V <sub>ENABLE</sub> = V <sub>CC</sub>	+25°C		10		nA
Input-Current Low	I <sub>AL</sub> , I <sub>BL</sub> , I <sub>CL</sub> , I <sub>ENABLEL</sub>	V <sub>A</sub> , V <sub>B</sub> , V <sub>C</sub> , V <sub>ENABLE</sub> = 0V	+25°C		10		nA
<b>Dynamic Characteristics</b>							
Address Transition Time	t <sub>TRANS</sub>	V <sub>X-</sub> = 3V/0V, R <sub>L</sub> = 300Ω, C <sub>L</sub> = 35pF, Test Circuit 1	+25°C		100		ns
ENABLE Turn-On Time	t <sub>ON</sub>	V <sub>X-</sub> = 3V, R <sub>L</sub> = 300Ω, C <sub>L</sub> = 35pF, Test Circuit 2	+25°C		80		ns
ENABLE Turn-Off Time	t <sub>OFF</sub>	V <sub>X-</sub> = 3V, R <sub>L</sub> = 300Ω, C <sub>L</sub> = 35pF, Test Circuit 2	+25°C		70		ns
Break-Before-Make Time Delay	t <sub>D</sub>	V <sub>X-</sub> = 3V, R <sub>L</sub> = 300Ω, C <sub>L</sub> = 35pF, Test Circuit 3	+25°C		40		ns
-3dB Bandwidth	BW	R <sub>L</sub> = 50Ω	+25°C		90		MHz
Charge Injection	Q	R <sub>S</sub> = 0Ω, C = 1nF, V <sub>S</sub> = 2.5V, Test Circuit 4	+25°C		2		pC
<b>Power Supply</b>							
Power Supply Range	V <sub>CC</sub> , V <sub>EE</sub>		Full	3.6		11	V
Power Supply Current	I <sub>CC</sub> , I <sub>EE</sub>	V <sub>CC</sub> = 5.5V, V <sub>A</sub> , V <sub>B</sub> , V <sub>C</sub> , V <sub>ENABLE</sub> = V <sub>CC</sub> or 0	+25°C		0.01	20	μA

**ELECTRICAL CHARACTERISTICS (Single Supply at +3.6V)**(V<sub>CC</sub> = 3.6V, V<sub>EE</sub> = 0V, Full = -40°C to +85°C, typical values are at T<sub>A</sub> = +25°C, unless otherwise noted.)

PARAMETER	SYMBOL	CONDITIONS	TEMP	MIN	TYP	MAX	UNITS
<b>Analog Switch</b>							
Analog Signal Range	V <sub>X-</sub> , V <sub>X</sub>		Full	V <sub>EE</sub>		V <sub>CC</sub>	V
On-Resistance	R <sub>ON</sub>	I <sub>X</sub> = 1mA	+25°C		100	130	Ω
			Full			140	
X <sub>-</sub> Off Leakage Current	I <sub>X(OFF)</sub>	V <sub>X-</sub> = 1V, 3V, V <sub>X</sub> = 3V, 1V	+25°C		10		nA
X Off Leakage Current	I <sub>X(OFF)</sub>	V <sub>X-</sub> = 1V, 3V, V <sub>X</sub> = 3V, 1V	+25°C		10		nA
X On Leakage Current	I <sub>X(ON)</sub>	V <sub>X</sub> = 3V, 1V	+25°C		10		nA
<b>Digital I/O</b>							
Logic Input Logic Threshold High	V <sub>AH</sub> , V <sub>BH</sub> , V <sub>CH</sub> , V <sub>ENABLEH</sub>		+25°C	2			V
Logic Input Logic Threshold Low	V <sub>AL</sub> , V <sub>BL</sub> , V <sub>CL</sub> , V <sub>ENABLEL</sub>		+25°C			0.5	V
Input-Current High	I <sub>AH</sub> , I <sub>BH</sub> , I <sub>CH</sub> , I <sub>ENABLEH</sub>	V <sub>A</sub> , V <sub>B</sub> , V <sub>C</sub> , V <sub>ENABLE</sub> = V <sub>CC</sub>	+25°C		10		nA
Input-Current Low	I <sub>AL</sub> , I <sub>BL</sub> , I <sub>CL</sub> , I <sub>ENABLEL</sub>	V <sub>A</sub> , V <sub>B</sub> , V <sub>C</sub> , V <sub>ENABLE</sub> = 0V	+25°C		10		nA
<b>Dynamic Characteristics</b>							
Address Transition Time	t <sub>TRANS</sub>	V <sub>X-</sub> = 3V/0V, R <sub>L</sub> = 300Ω, C <sub>L</sub> = 35pF, Test Circuit 1	+25°C		160		ns
ENABLE Turn-On Time	t <sub>ON</sub>	V <sub>X-</sub> = 3V, R <sub>L</sub> = 300Ω, C <sub>L</sub> = 35pF, Test Circuit 2	+25°C		130		ns
ENABLE Turn-Off Time	t <sub>OFF</sub>	V <sub>X-</sub> = 3V, R <sub>L</sub> = 300Ω, C <sub>L</sub> = 35pF, Test Circuit 2	+25°C		90		ns
Break-Before-Make Time Delay	t <sub>D</sub>	V <sub>X-</sub> = 3V, R <sub>L</sub> = 300Ω, C <sub>L</sub> = 35pF, Test Circuit 3	+25°C		60		ns
-3dB Bandwidth	BW	R <sub>L</sub> = 50Ω	+25°C		90		MHz
Charge Injection	Q	R <sub>S</sub> = 0Ω, C = 1nF, V <sub>S</sub> = 2.5V, Test Circuit 4	+25°C		1		pC
<b>Power Supply</b>							
Power Supply Current	I <sub>CC</sub> , I <sub>EE</sub>	V <sub>A</sub> , V <sub>B</sub> , V <sub>C</sub> , V <sub>ENABLE</sub> = V <sub>CC</sub> or 0	+25°C		0.01	20	μA

TYPICAL PERFORMANCE CHARACTERISTICS

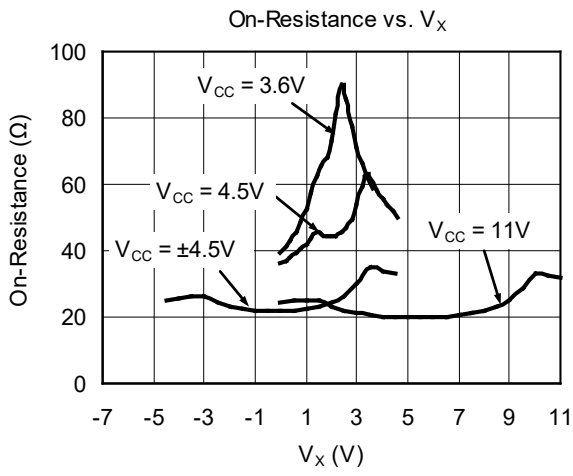



TEST CIRCUITS

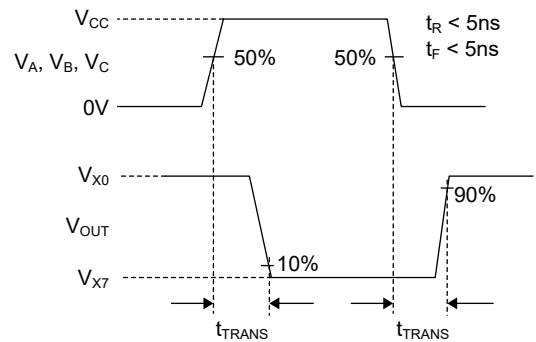
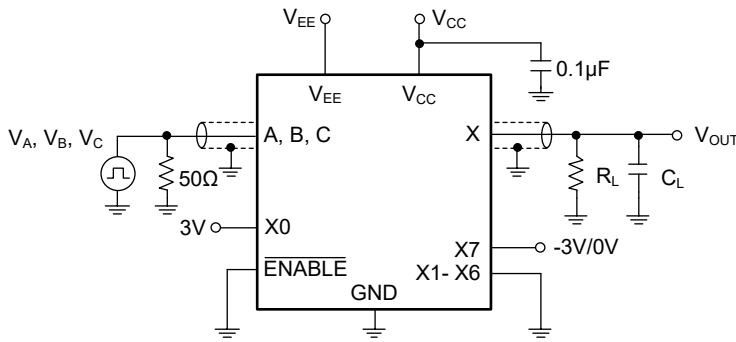

Test Circuit 1. Address Transition Times ( $t_{TRANS}$ )

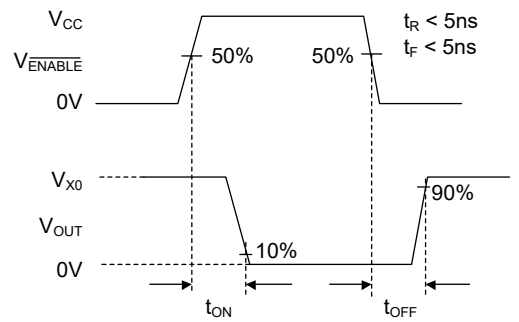
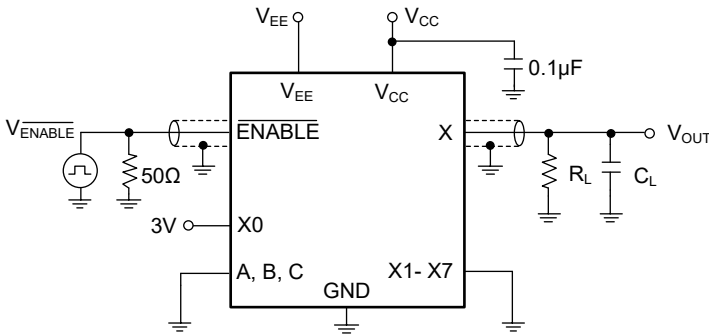

Test Circuit 2. Switching Times ( $t_{ON}$ ,  $t_{OFF}$ )

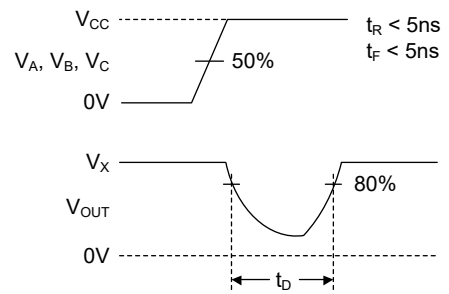
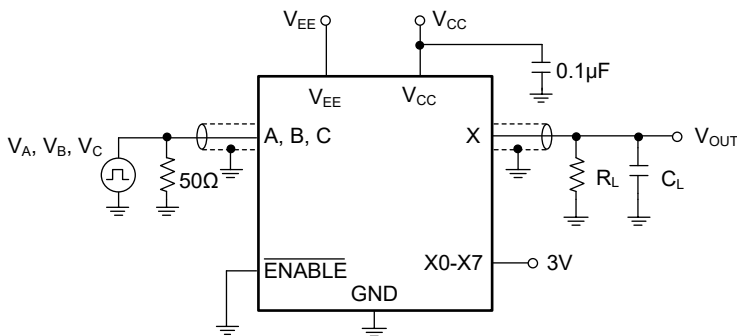

Test Circuit 3. Break-Before-Make Time Delay ( $t_D$ )

TEST CIRCUITS (continued)

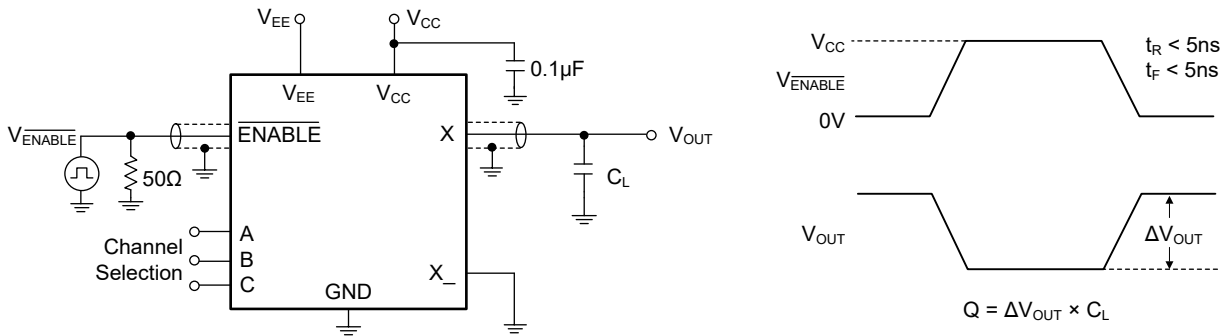

Test Circuit 4. Charge Injection (Q)

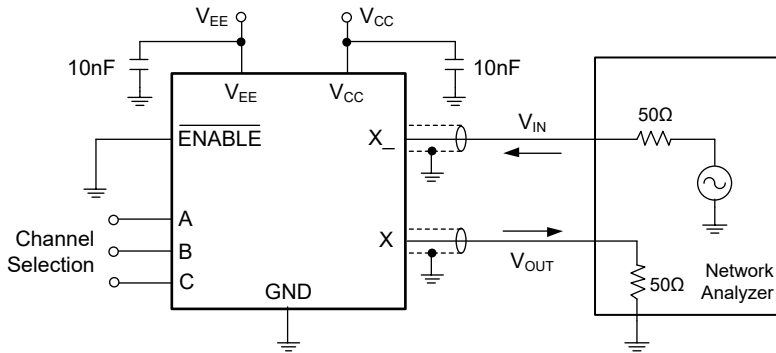

Off-Isolation =  $20\log(V_{OUT}/V_{IN})$  (Measured between X and "OFF" X\_ Terminal on Each Switch)

On Loss =  $20\log(V_{OUT}/V_{IN})$  (Measured between X and "ON" X\_ Terminal on Each Switch)

Test Circuit 5. Off-Isolation, On Loss

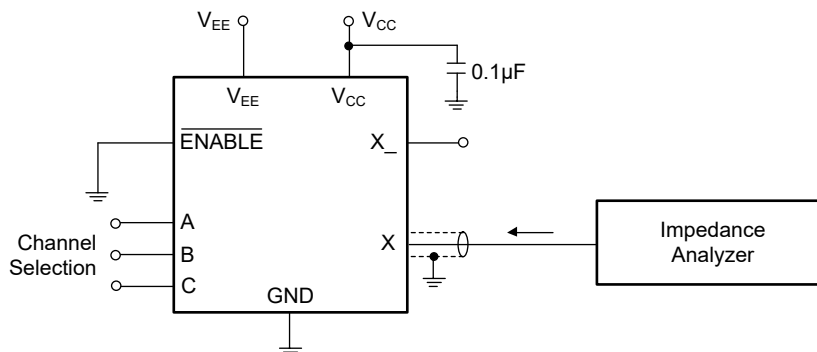

Test Circuit 6. Capacitance

---

**REVISION HISTORY**

NOTE: Page numbers for previous revisions may differ from page numbers in the current version.

**AUGUST 2022 – REV.A.2 to REV.A.3****Page**

---

Updated Test Circuits section .....9

---

**JANUARY 2014 – REV.A.1 to REV.A.2**

---

ENABLE pin change to  $\overline{\text{ENABLE}}$  pin .....All

---

**JULY 2013 – REV.A to REV.A.1**

---

Changed Electrical Characteristics section ..... 5, 6

---

**Changes from Original (AUGUST 2012) to REV.A**

---

Changed from product preview to production data.....All

---

PACKAGE OUTLINE DIMENSIONS

SOIC-16

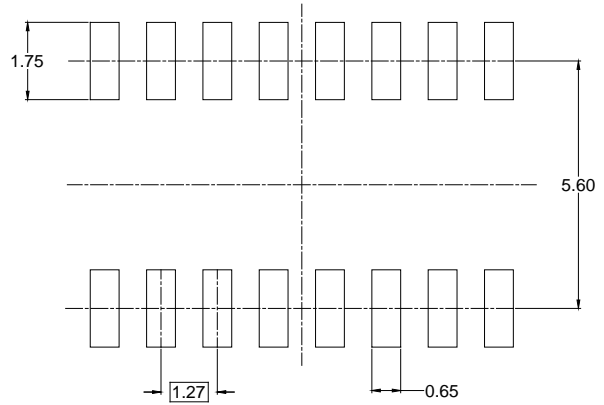
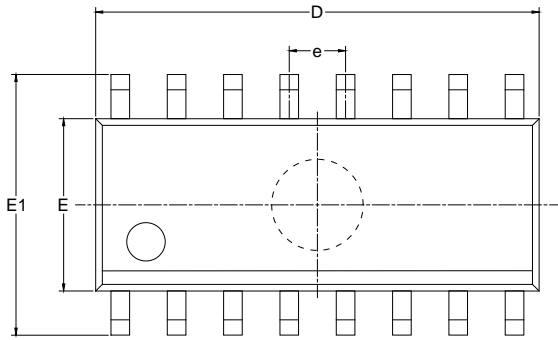

RECOMMENDED LAND PATTERN (Unit: mm)

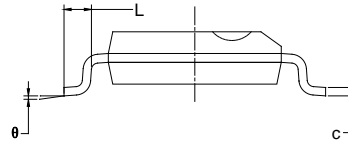
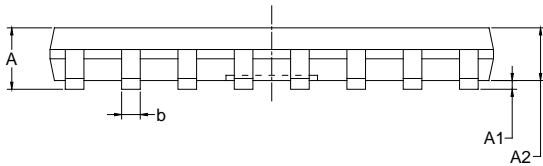

Symbol	Dimensions In Millimeters		Dimensions In Inches	
	MIN	MAX	MIN	MAX
A	1.350	1.750	0.053	0.069
A1	0.100	0.250	0.004	0.010
A2	1.350	1.550	0.053	0.061
b	0.330	0.510	0.013	0.020
c	0.170	0.250	0.006	0.010
D	9.800	10.200	0.386	0.402
E	3.800	4.000	0.150	0.157
E1	5.800	6.200	0.228	0.244
e	1.27 BSC		0.050 BSC	
L	0.400	1.270	0.016	0.050
θ	0°	8°	0°	8°

NOTES:

1. Body dimensions do not include mode flash or protrusion.
2. This drawing is subject to change without notice.

PACKAGE OUTLINE DIMENSIONS

SSOP-16

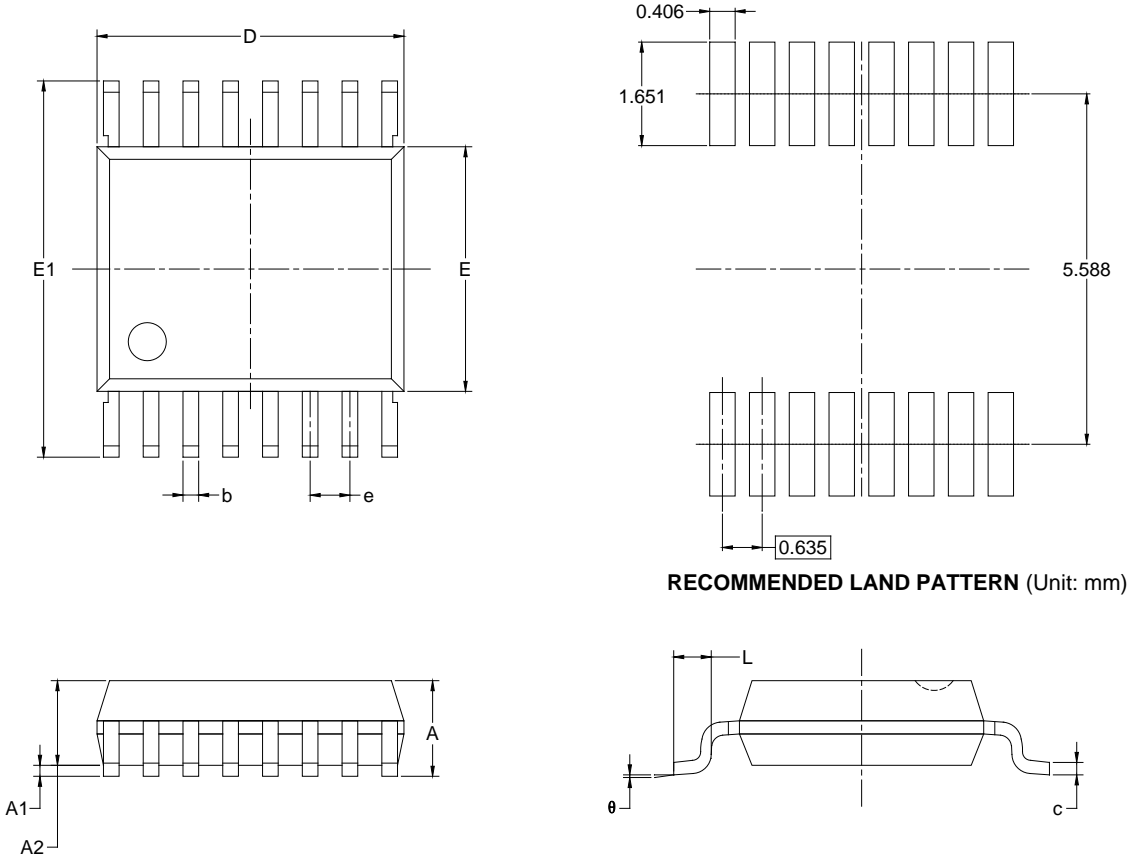

RECOMMENDED LAND PATTERN (Unit: mm)

Symbol	Dimensions In Millimeters		Dimensions In Inches	
	MIN	MAX	MIN	MAX
A	1.350	1.750	0.053	0.069
A1	0.100	0.250	0.004	0.010
A2	1.350	1.550	0.053	0.061
b	0.200	0.300	0.008	0.012
c	0.170	0.250	0.007	0.010
D	4.700	5.100	0.185	0.200
E	3.800	4.000	0.150	0.157
E1	5.800	6.200	0.228	0.244
e	0.635 BSC		0.025 BSC	
L	0.400	1.270	0.016	0.050
θ	0°	8°	0°	8°

NOTES:  
 1. Body dimensions do not include mode flash or protrusion.  
 2. This drawing is subject to change without notice.

PACKAGE OUTLINE DIMENSIONS

TSSOP-16

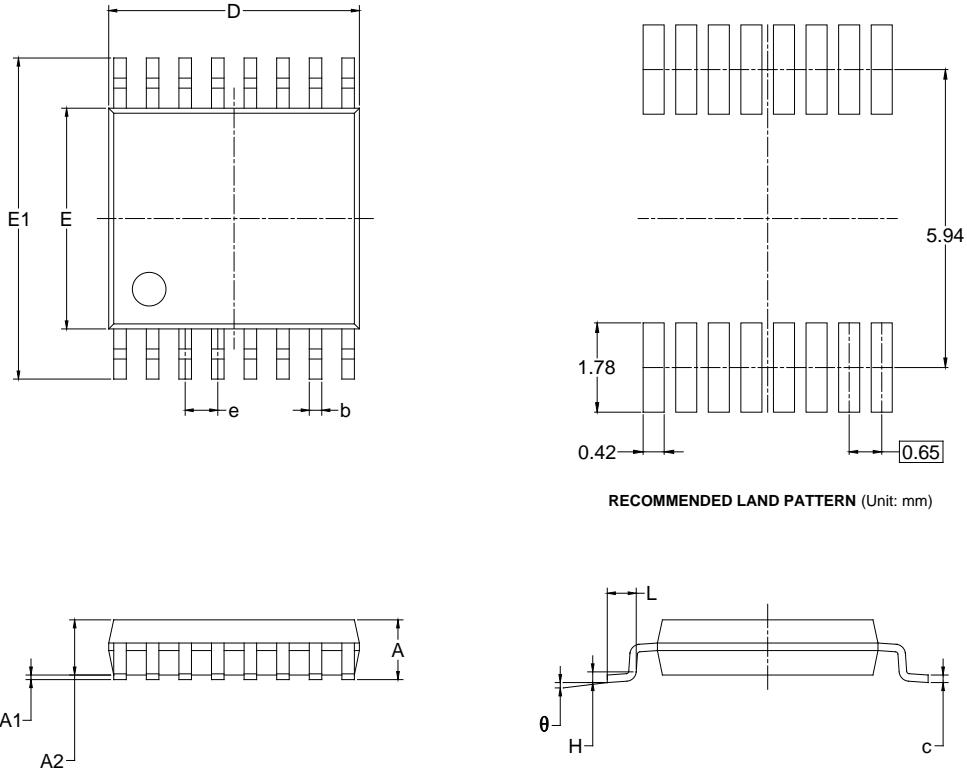

RECOMMENDED LAND PATTERN (Unit: mm)

Symbol	Dimensions In Millimeters		Dimensions In Inches	
	MIN	MAX	MIN	MAX
A		1.200		0.047
A1	0.050	0.150	0.002	0.006
A2	0.800	1.050	0.031	0.041
b	0.190	0.300	0.007	0.012
c	0.090	0.200	0.004	0.008
D	4.860	5.100	0.191	0.201
E	4.300	4.500	0.169	0.177
E1	6.200	6.600	0.244	0.260
e	0.650 BSC		0.026 BSC	
L	0.500	0.700	0.02	0.028
H	0.25 TYP		0.01 TYP	
θ	1°	7°	1°	7°

- NOTES:
1. Body dimensions do not include mode flash or protrusion.
  2. This drawing is subject to change without notice.

# PACKAGE INFORMATION

## PACKAGE OUTLINE DIMENSIONS

### TQFN-3x3-16L

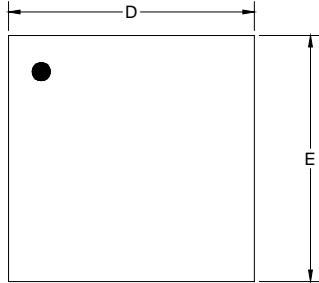

TOP VIEW

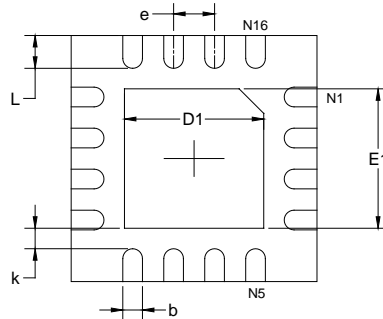

BOTTOM VIEW

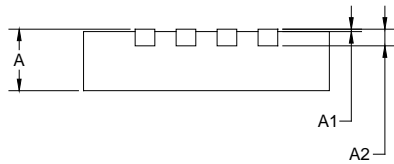

SIDE VIEW

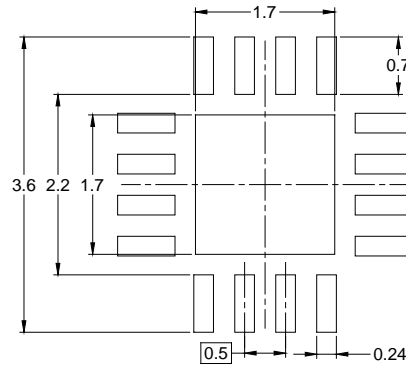

RECOMMENDED LAND PATTERN (Unit: mm)

Symbol	Dimensions In Millimeters		Dimensions In Inches	
	MIN	MAX	MIN	MAX
A	0.700	0.800	0.028	0.031
A1	0.000	0.050	0.000	0.002
A2	0.203 REF		0.008 REF	
D	2.900	3.100	0.114	0.122
D1	1.600	1.800	0.063	0.071
E	2.900	3.100	0.114	0.122
E1	1.600	1.800	0.063	0.071
k	0.200 MIN		0.008 MIN	
b	0.180	0.300	0.007	0.012
e	0.500 TYP		0.020 TYP	
L	0.300	0.500	0.012	0.020

NOTE: This drawing is subject to change without notice.

# PACKAGE INFORMATION

## TAPE AND REEL INFORMATION

### REEL DIMENSIONS

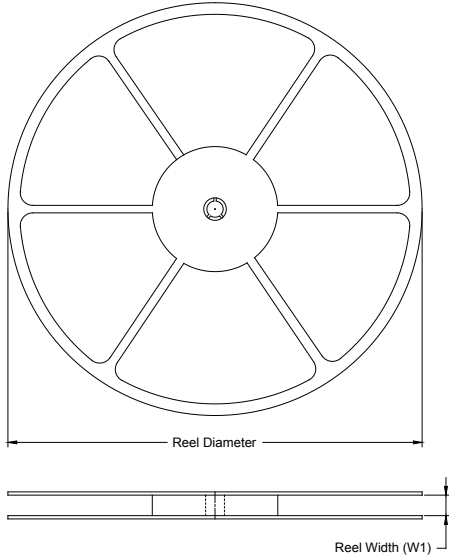

### TAPE DIMENSIONS

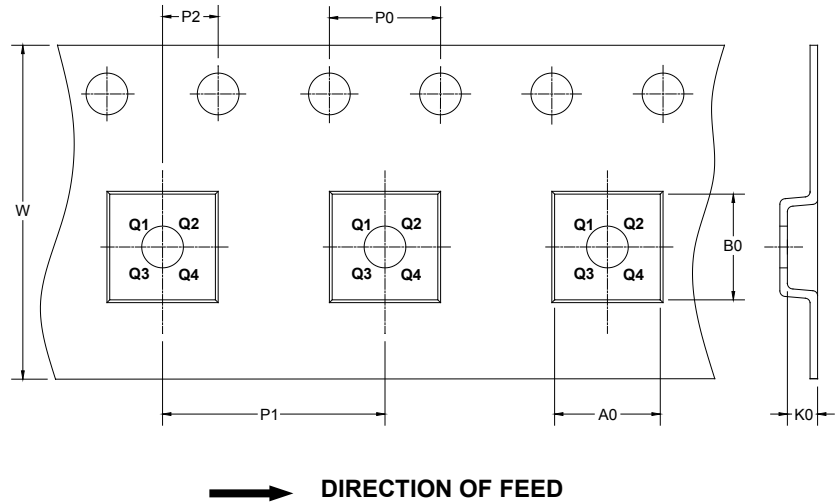

NOTE: The picture is only for reference. Please make the object as the standard.

### KEY PARAMETER LIST OF TAPE AND REEL

Package Type	Reel Diameter	Reel Width W1 (mm)	A0 (mm)	B0 (mm)	K0 (mm)	P0 (mm)	P1 (mm)	P2 (mm)	W (mm)	Pin1 Quadrant
SOIC-16	13"	16.4	6.50	10.30	2.10	4.0	8.0	2.0	16.0	Q1
SSOP-16	13"	12.4	6.40	5.40	2.10	4.0	8.0	2.0	12.0	Q1
TSSOP-16	13"	12.4	6.90	5.60	1.50	4.0	8.0	2.0	12.0	Q1
TQFN-3×3-16L	13"	12.4	3.35	3.35	1.13	4.0	8.0	2.0	12.0	Q1

DD0001



# PACKAGE INFORMATION

## CARTON BOX DIMENSIONS



NOTE: The picture is only for reference. Please make the object as the standard.

## KEY PARAMETER LIST OF CARTON BOX

Reel Type	Length (mm)	Width (mm)	Height (mm)	Pizza/Carton
13"	386	280	370	5

DD0002