



# SGM51223Q

## Automotive, 12-Bit, 2MSPS, 1-Channel, Single-Ended, Serial Interface ADC

### GENERAL DESCRIPTION

The SGM51223Q is a 12-bit, 1-channel input, successive approximation (SAR) analog-to-digital converter (ADC).

The SGM51223Q analog power supply range is 2.35V to 3.6V. The SGM51223Q has an SPI-compatible interface with the digital power supply range of 1.65V to 3.6V.

The device is AEC-Q100 qualified (Automotive Electronics Council (AEC) standard Q100 Grade 1) and it is suitable for automotive applications.

The SGM51223Q is available in a Green VSSOP-8 package. It operates over an ambient temperature range -40°C to +125°C.

### FEATURES

- **AEC-Q100 Qualified for Automotive Applications**  
Device Temperature Grade 1  
 $T_A = -40^{\circ}\text{C}$  to  $+125^{\circ}\text{C}$
- **Unipolar Input Range: 0V to AVDD**
- **Support Single-Ended Input**
- **Ultra-Low Power Consumption:**  
3.96mW (TYP) at 2MSPS with 3.6V AVDD
- **Throughput:**  
2MSPS with Zero Data Latency
- **Excellent Performance:**
  - ♦ **12-Bit Resolution with NMC**
  - ♦ **INL:  $\pm 0.8\text{LSB}$  (TYP)**
  - ♦ **DNL:  $\pm 0.5\text{LSB}$  (TYP)**
  - ♦ **SNR: 72dB (TYP) at  $f_{\text{IN}} = 2\text{kHz}$**
  - ♦ **THD: -80dB (TYP) at  $f_{\text{IN}} = 2\text{kHz}$**
- **Integrated Offset Calibration**
- **SPI-Compatible Serial Interface**
- **Operating Temperature Range: -40°C to +125°C**
- **Available in a Green VSSOP-8 Package**

### APPLICATIONS

Automotive Infotainment  
Automotive Sensors  
Portable Medical Equipment  
Ultrasonic Flow Meters  
Motor Control  
Level Sensors

**PACKAGE/ORDERING INFORMATION**

| MODEL     | PACKAGE DESCRIPTION | SPECIFIED TEMPERATURE RANGE | ORDERING NUMBER  | PACKAGE MARKING | PACKING OPTION      |
|-----------|---------------------|-----------------------------|------------------|-----------------|---------------------|
| SGM51223Q | VSSOP-8             | -40°C to +125°C             | SGM51223QVS8G/TR | 0PB<br>XXXX     | Tape and Reel, 3000 |

**MARKING INFORMATION**

NOTE: XXXX = Date Code, Trace Code and Vendor Code.

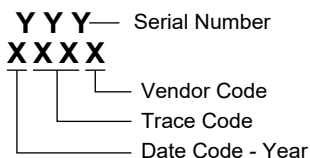

Green (RoHS & HSF): SG Micro Corp defines "Green" to mean Pb-Free (RoHS compatible) and free of halogen substances. If you have additional comments or questions, please contact your SGMICRO representative directly.

**ABSOLUTE MAXIMUM RATINGS**

Voltage Range (with Respected to GND)

|                             |                      |
|-----------------------------|----------------------|
| AVDD .....                  | -0.3V to 3.9V        |
| DVDD .....                  | -0.3V to 3.9V        |
| AINP .....                  | -0.3V to AVDD + 0.3V |
| AINM .....                  | -0.3V to 0.3V        |
| Digital Input Voltage ..... | -0.3V to DVDD + 0.3V |

Package Thermal Resistance

|                              |           |
|------------------------------|-----------|
| VSSOP-8, $\theta_{JA}$ ..... | 166.2°C/W |
| VSSOP-8, $\theta_{JB}$ ..... | 98°C/W    |
| VSSOP-8, $\theta_{JC}$ ..... | 68.5°C/W  |

Junction Temperature .....

Storage Temperature Range .....

Lead Temperature (Soldering, 10s) .....

ESD Susceptibility <sup>(1) (2)</sup>

HBM .....

CDM .....

NOTES:

1. For human body model (HBM), all pins comply with AEC-Q100-002 specification.
2. For charged device model (CDM), all pins comply with AEC-Q100-011 specification.

**RECOMMENDED OPERATING CONDITIONS**

Analog Supply Voltage Range, AVDD .....

Digital Supply Voltage Range, DVDD .....

Operating Temperature Range .....

**OVERSTRESS CAUTION**

Stresses beyond those listed in Absolute Maximum Ratings may cause permanent damage to the device. Exposure to absolute maximum rating conditions for extended periods may affect reliability. Functional operation of the device at any conditions beyond those indicated in the Recommended Operating Conditions section is not implied.

**ESD SENSITIVITY CAUTION**

This integrated circuit can be damaged if ESD protections are not considered carefully. SGMICRO recommends that all integrated circuits be handled with appropriate precautions. Failure to observe proper handling and installation procedures can cause damage. ESD damage can range from subtle performance degradation to complete device failure. Precision integrated circuits may be more susceptible to damage because even small parametric changes could cause the device not to meet the published specifications.

**DISCLAIMER**

SG Micro Corp reserves the right to make any change in circuit design, or specifications without prior notice.

**PIN CONFIGURATION**

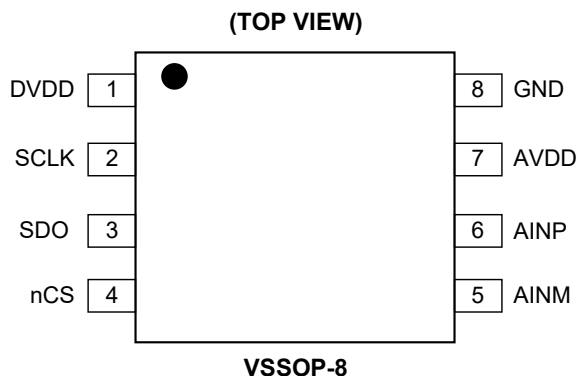

**PIN DESCRIPTION**

| PIN | NAME | TYPE | FUNCTION                                                                           |
|-----|------|------|------------------------------------------------------------------------------------|
| 1   | DVDD | P    | Digital Supply Voltage Pin.                                                        |
| 2   | SCLK | DI   | Serial Clock Pin.                                                                  |
| 3   | SDO  | DO   | Serial Data Out Pin.                                                               |
| 4   | nCS  | DI   | Chip Select Pin. Active low.                                                       |
| 5   | AINM | AI   | Negative Analog Signal Input Pin.                                                  |
| 6   | AINP | AI   | Positive Analog Signal Input Pin.                                                  |
| 7   | AVDD | P    | Analog Power Supply Input Pin. It also provides the reference voltage for the ADC. |
| 8   | GND  | P    | Ground.                                                                            |

NOTE: AI = analog input, DI = digital input, DO = digital output, P = power.

# Automotive, 12-Bit, 2MSPS, 1-Channel, Single-Ended, Serial Interface ADC

## SGM51223Q

### ELECTRICAL CHARACTERISTICS

(T<sub>A</sub> = -40°C to +125°C, AVDD = 2.35V to 3.6V, DVDD = 1.8V to 3.6V, f<sub>SAMPLE</sub> = 2MSPS, and V<sub>AINM</sub> = 0V, unless otherwise noted.)

| PARAMETER                                    | SYMBOL               | CONDITIONS                       | MIN    | TYP  | MAX        | UNITS              |
|----------------------------------------------|----------------------|----------------------------------|--------|------|------------|--------------------|
| <b>Analog Input</b>                          |                      |                                  |        |      |            |                    |
| Full-Scale Input Voltage Span <sup>(1)</sup> |                      | AINP - AINM                      | 0      |      | AVDD       | V                  |
| Absolute Input Voltage Range                 |                      | AINP to GND                      | -0.1   |      | AVDD + 0.1 | V                  |
|                                              |                      | AINM to GND                      | -0.1   |      | 0.1        |                    |
| Sampling Capacitance <sup>(6)</sup>          | C <sub>s</sub>       |                                  |        | 18   |            | pF                 |
| <b>System Performance</b>                    |                      |                                  |        |      |            |                    |
| Resolution                                   |                      |                                  |        | 12   |            | Bits               |
| No Missing Codes                             | NMC                  |                                  | 12     |      |            | Bits               |
| Integral Nonlinearity                        | INL                  |                                  | -3.5   | ±0.8 | 3.2        | LSB <sup>(2)</sup> |
| Differential Nonlinearity                    | DNL                  |                                  | -0.999 | ±0.5 | 1          | LSB                |
| Offset Error                                 | E <sub>O</sub>       | Uncalibrated                     |        | ±16  |            | LSB                |
|                                              |                      | Calibrated <sup>(3)</sup>        | -2.5   | 0.5  | 3          |                    |
| Offset Error Drift with Temperature          | dV <sub>OS</sub> /dT |                                  |        | 1.8  |            | ppm/°C             |
| Gain Error                                   | E <sub>G</sub>       |                                  | -0.22  | -0.1 | 0.033      | %FS                |
| Gain Error Drift with Temperature            |                      | No calibration                   |        | 1.9  |            | ppm/°C             |
| <b>Sampling Dynamics</b>                     |                      |                                  |        |      |            |                    |
| Acquisition Time                             | t <sub>ACQ</sub>     |                                  | 90     |      |            | ns                 |
| Maximum Throughput Rate                      |                      | 32MHz SCLK, AVDD = 2.35V to 3.6V |        |      | 2          | MHz                |
| <b>Dynamic Characteristics</b>               |                      |                                  |        |      |            |                    |
| Signal-to-Noise Ratio <sup>(4)</sup>         | SNR                  | f <sub>IN</sub> = 250kHz         |        | 72   |            | dB                 |
|                                              |                      | f <sub>IN</sub> = 2kHz           | 66.5   | 72   |            |                    |
| Total Harmonic Distortion <sup>(4) (5)</sup> | THD                  | f <sub>IN</sub> = 250kHz         |        | -79  |            | dB                 |
|                                              |                      | f <sub>IN</sub> = 2kHz           | -67    | -80  |            |                    |
| Signal-to-Noise + Distortion <sup>(4)</sup>  | SINAD                | f <sub>IN</sub> = 250kHz         |        | 71   |            | dB                 |
|                                              |                      | f <sub>IN</sub> = 2kHz           | 65     | 71   |            |                    |
| Spurious Free Dynamic Range <sup>(4)</sup>   | SFDR                 | f <sub>IN</sub> = 250kHz         |        | 80   |            | dB                 |
|                                              |                      | f <sub>IN</sub> = 2kHz           | 67.5   | 80   |            |                    |
| Full Power Bandwidth                         | BW <sub>(fp)</sub>   | At -3dB, AVDD = 2.35V to 3.6V    |        | 100  |            | MHz                |

**NOTES:**

1. Ideal input range. It does not consider gain and offset error.
2. LSB = Least Significant Bit.
3. Refer to the Offset Calibration section. It is recommended to perform offset calibration during normal operation.
4. All specifications are tested with an input signal at 0.5dB below full-scale, unless otherwise noted. All available input ranges are described in full-scale input range (FSR), but not performance guaranteed.
5. Calculated on the first nine harmonics of the input frequency.
6. Guaranteed by design and characterization. Not production tested.

**ELECTRICAL CHARACTERISTICS (continued)**(T<sub>A</sub> = -40°C to +125°C, AVDD = 2.35V to 3.6V, DVDD = 1.65V to 3.6V, f<sub>SAMPLE</sub> = 2MSPS, and V<sub>AINM</sub> = 0V, unless otherwise noted.)

| PARAMETER                                       | SYMBOL            | CONDITIONS                           | MIN         | TYP  | MAX        | UNITS |
|-------------------------------------------------|-------------------|--------------------------------------|-------------|------|------------|-------|
| <b>Digital Input/Output (CMOS Logic Family)</b> |                   |                                      |             |      |            |       |
| High-Level Input Voltage                        | V <sub>IH</sub>   |                                      | 0.7 × DVDD  |      | DVDD + 0.3 | V     |
| Low-Level Input Voltage                         | V <sub>IL</sub>   |                                      | -0.3        |      | 0.3 × DVDD | V     |
| High-Level Output Voltage                       | V <sub>OH</sub>   | I <sub>SOURCE</sub> = 500μA          | 0.8 × DVDD  |      | DVDD       | V     |
|                                                 |                   | I <sub>SOURCE</sub> = 2mA            | DVDD - 0.45 |      | DVDD       |       |
| Low-Level Output Voltage                        | V <sub>OL</sub>   | I <sub>SINK</sub> = 500μA            | 0           |      | 0.2 × DVDD | V     |
|                                                 |                   | I <sub>SINK</sub> = 2mA              | 0           |      | 0.45       |       |
| <b>Power Supply Requirements</b>                |                   |                                      |             |      |            |       |
| Analog Supply Voltage                           | AVDD              |                                      | 2.35        | 3    | 3.6        | V     |
| Digital I/O Supply Voltage                      | DVDD              |                                      | 1.65        | 3    | 3.6        | V     |
| Analog Supply Current                           | I <sub>AVDD</sub> | At 2MSPS with AVDD = 3.6V            |             | 1100 | 1300       | μA    |
| Digital Supply Current                          | I <sub>DVDD</sub> | AVDD = 3.6V, no load, no transitions |             | 10   |            | μA    |
| Power Dissipation                               | P <sub>D</sub>    | At 2MSPS with AVDD = 3.6V            |             | 3.96 | 4.68       | mW    |

**TIMING REQUIREMENTS**

( $T_A = -40^{\circ}\text{C}$  to  $+125^{\circ}\text{C}$ ,  $AVDD = 2.35\text{V}$  to  $3.6\text{V}$ ,  $DVDD = 1.65\text{V}$  to  $3.6\text{V}$ , and  $C_{LOAD}$  on SDO =  $20\text{pF}$ , unless otherwise noted.)

| PARAMETER                                   | SYMBOL     | CONDITIONS | MIN   | TYP | MAX  | UNITS      |
|---------------------------------------------|------------|------------|-------|-----|------|------------|
| Acquisition Time                            | $t_2$      |            | 90    |     |      | ns         |
| SCLK Frequency                              | $f_{SCLK}$ |            | 0.016 |     | 32   | MHz        |
| SCLK Period                                 | $t_6$      |            | 31.25 |     |      | ns         |
| SCLK High Time                              | $t_4$      |            | 0.45  |     | 0.55 | $t_{SCLK}$ |
| SCLK Low Time                               | $t_5$      |            | 0.45  |     | 0.55 | $t_{SCLK}$ |
| nCS High Time                               | $t_7$      |            | 30    |     |      | ns         |
| Setup Time: nCS Falling to SCLK Falling     | $t_3$      |            | 12    |     |      | ns         |
| Delay Time: Last SCLK Falling to nCS Rising | $t_8$      |            | 10    |     |      | ns         |

**SWITCHING CHARACTERISTICS**

( $T_A = -40^{\circ}\text{C}$  to  $+125^{\circ}\text{C}$ ,  $AVDD = 2.35\text{V}$  to  $3.6\text{V}$ ,  $DVDD = 1.65\text{V}$  to  $3.6\text{V}$ , and  $C_{LOAD}$  on SDO =  $20\text{pF}$ , unless otherwise noted.)

| PARAMETER                                             | SYMBOL           | CONDITIONS           | MIN | TYP                     | MAX | UNITS         |
|-------------------------------------------------------|------------------|----------------------|-----|-------------------------|-----|---------------|
| Throughput                                            | $f_{THROUGHPUT}$ |                      |     |                         | 2   | MSPS          |
| Cycle Time                                            | $t_c$            |                      | 0.5 |                         |     | $\mu\text{s}$ |
| Conversion Time                                       | $t_1$            |                      |     | $12.5 \times t_6 + t_3$ |     | ns            |
| Delay Time: nCS Falling to Data Enable                | $t_9$            | DVDD = 1.65V to 1.8V |     |                         | 20  | ns            |
|                                                       |                  | DVDD = 1.8V to 3.6V  |     |                         | 15  |               |
| Delay Time: SCLK Falling to (Next) Data Valid on DOUT | $t_{10}$         | DVDD = 1.65V to 1.8V |     |                         | 30  | ns            |
|                                                       |                  | DVDD = 1.8V to 3.6V  |     |                         | 25  |               |
| Delay Time: nCS Rising to DOUT Going to Tri-State     | $t_{11}$         |                      | 5   |                         |     | ns            |

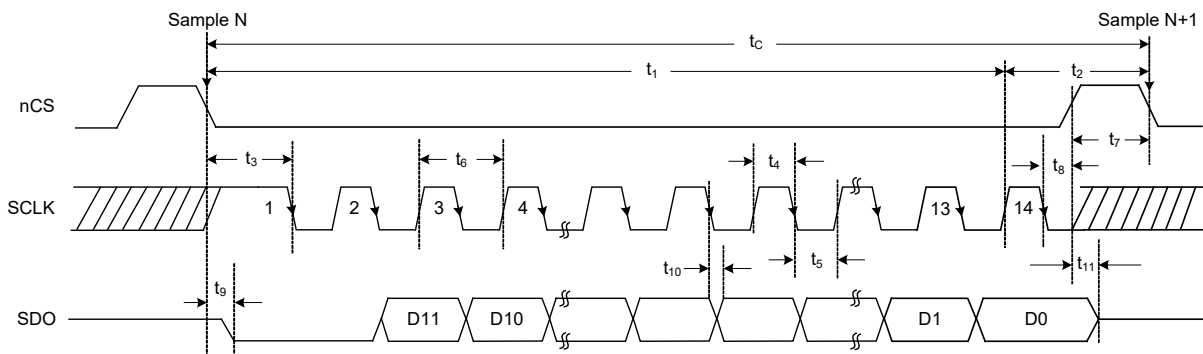
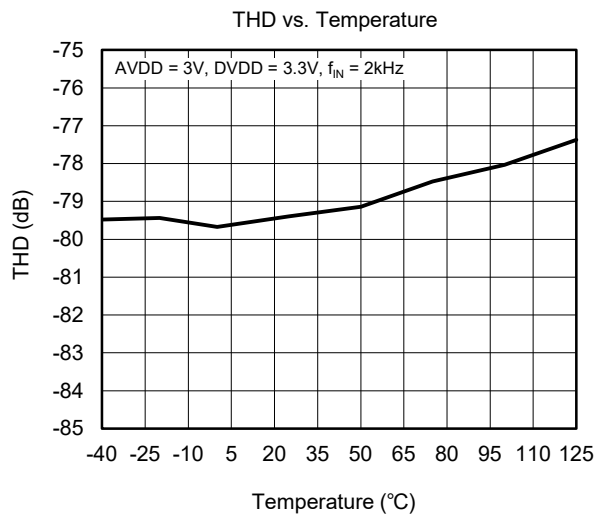
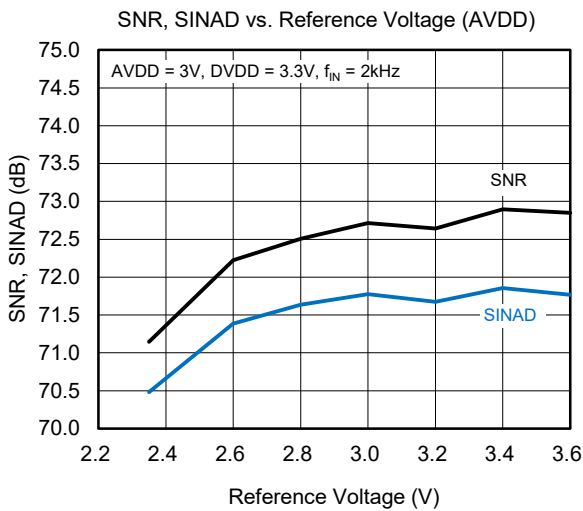
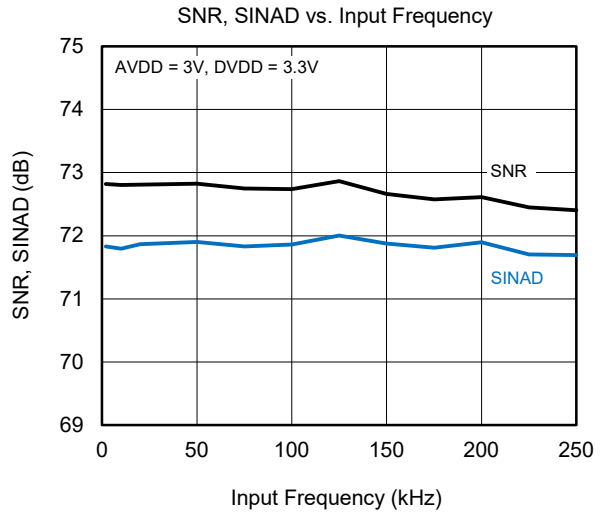
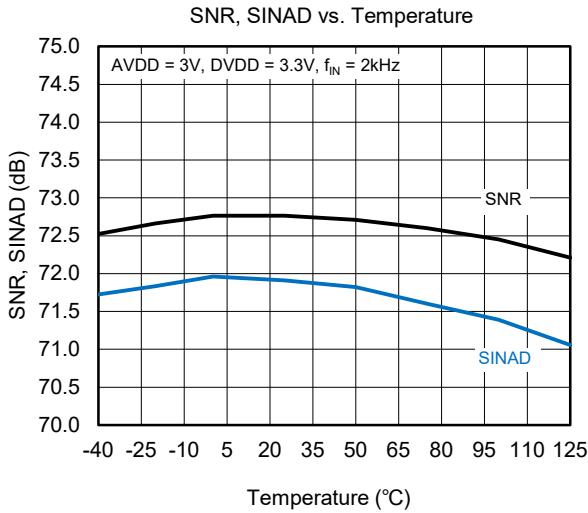
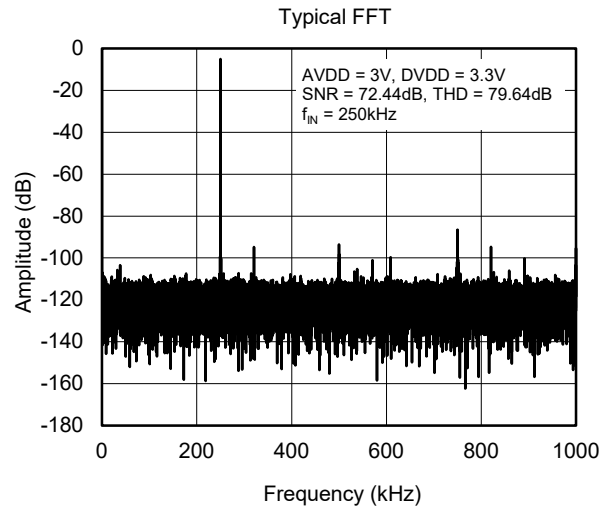
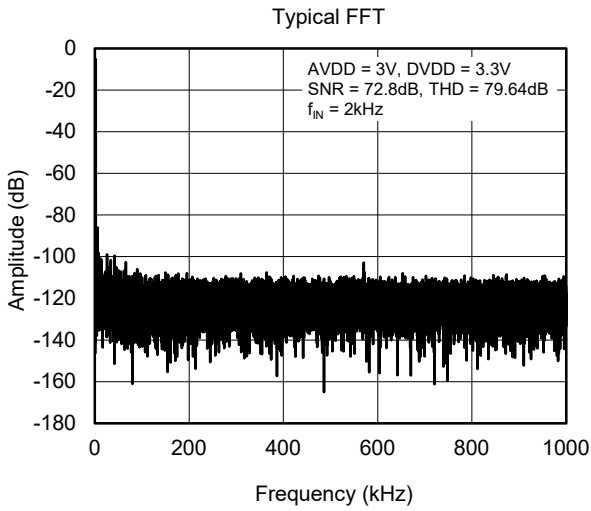

Figure 1. Serial Interface Timing Diagram

TYPICAL PERFORMANCE CHARACTERISTICS

T<sub>A</sub> = +25°C, AVDD = 3V, DVDD = 3.3V, and f<sub>SAMPLE</sub> = 2MSPS, unless otherwise noted.



**TYPICAL PERFORMANCE CHARACTERISTICS (continued)**

T<sub>A</sub> = +25°C, AVDD = 3V, DVDD = 3.3V, and f<sub>SAMPLE</sub> = 2MSPS, unless otherwise noted.

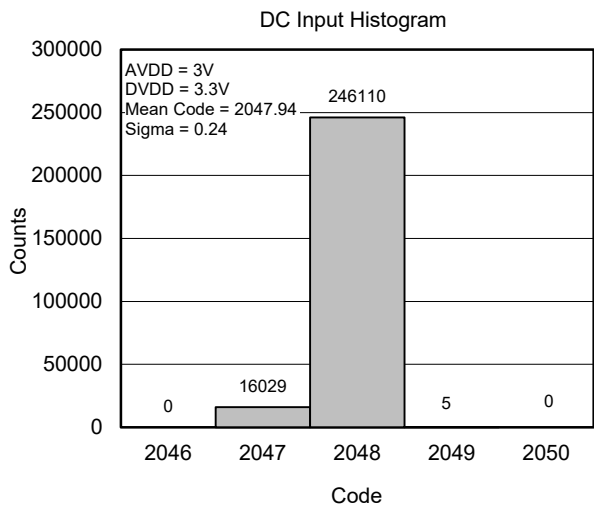
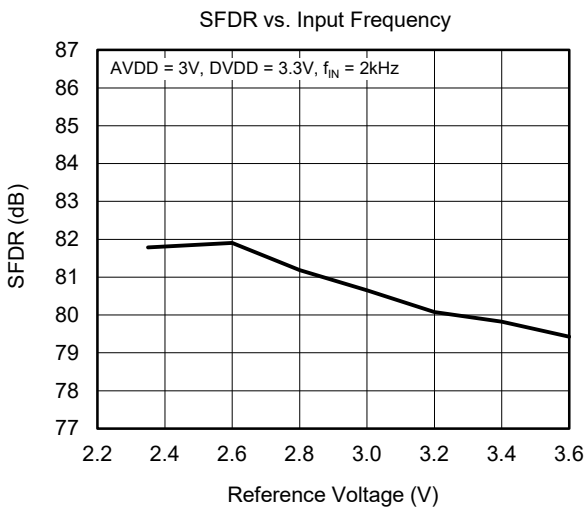
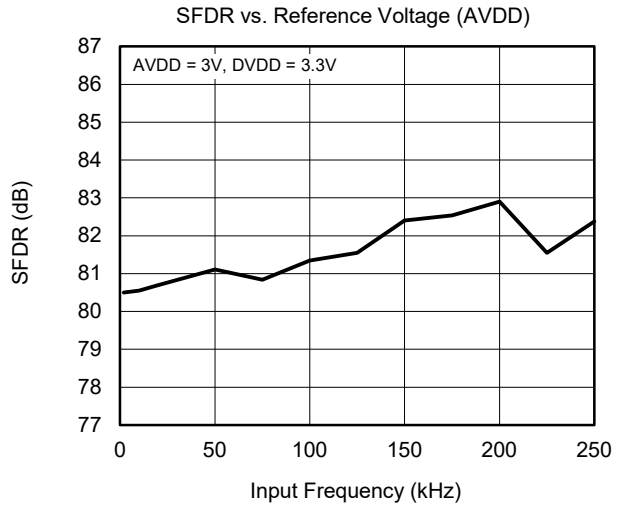
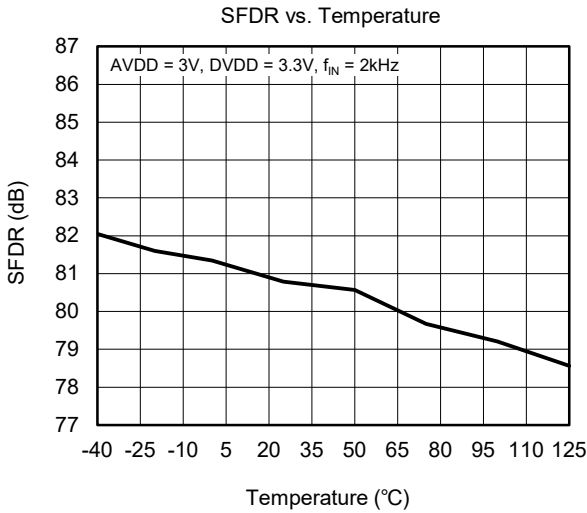
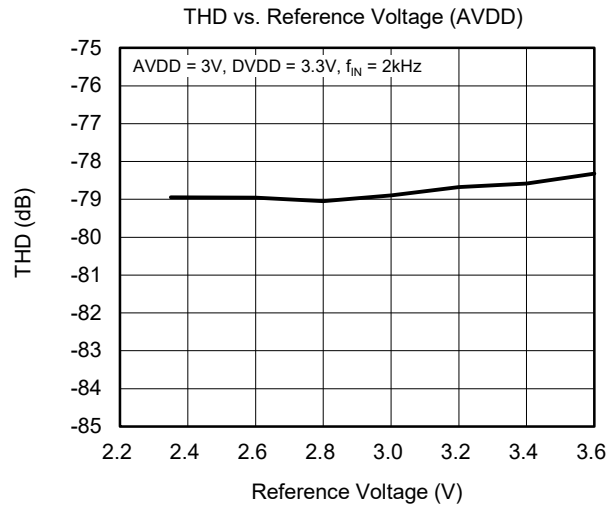
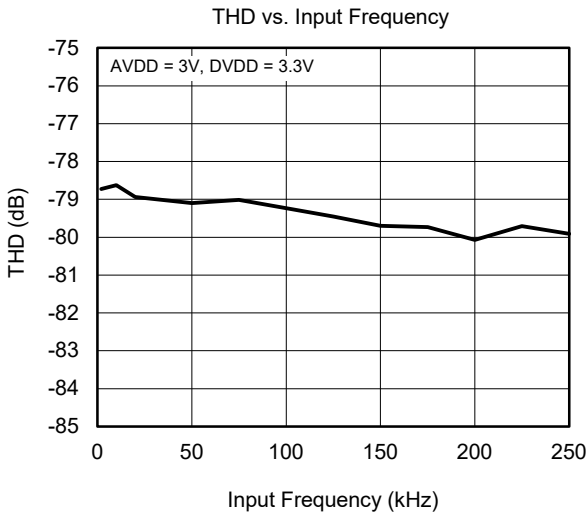



TYPICAL PERFORMANCE CHARACTERISTICS (continued)

T<sub>A</sub> = +25°C, AVDD = 3V, DVDD = 3.3V, and f<sub>SAMPLE</sub> = 2MSPS, unless otherwise noted.

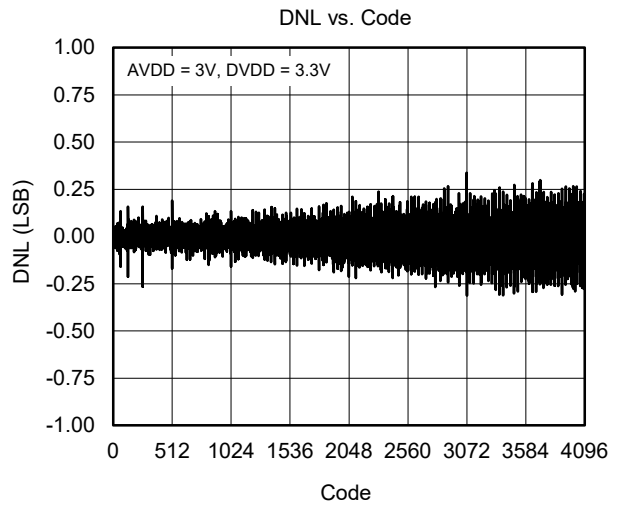
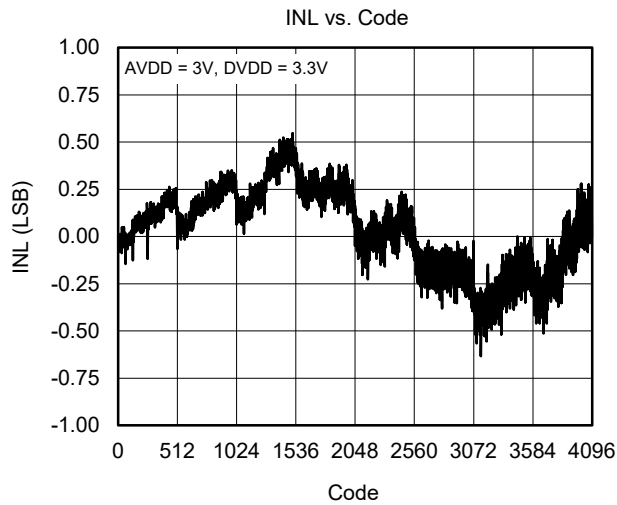
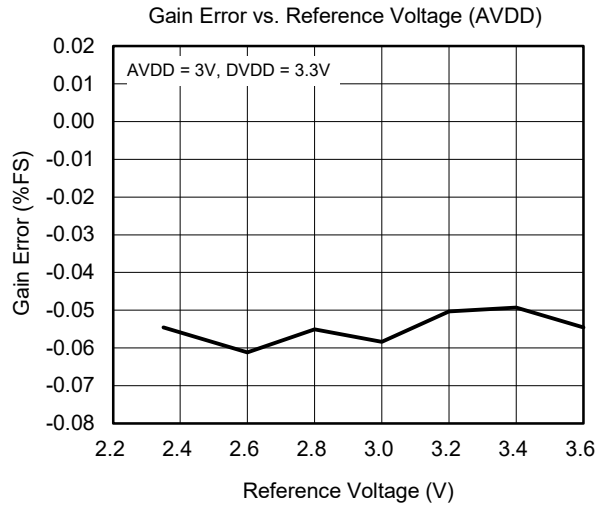
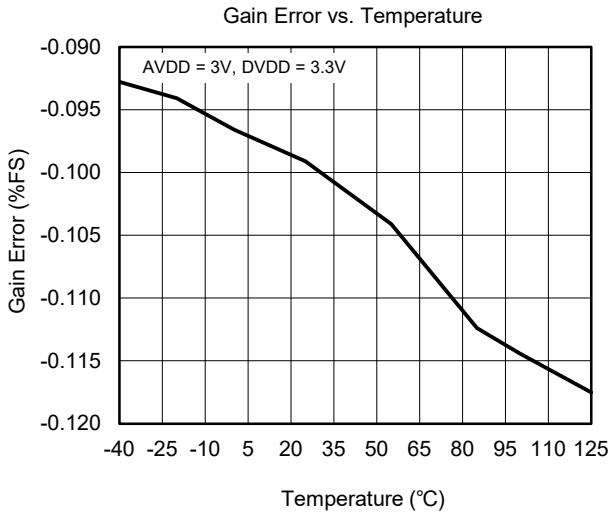
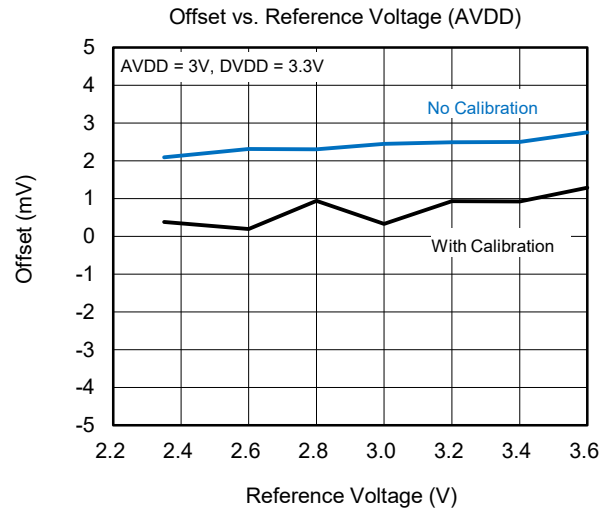
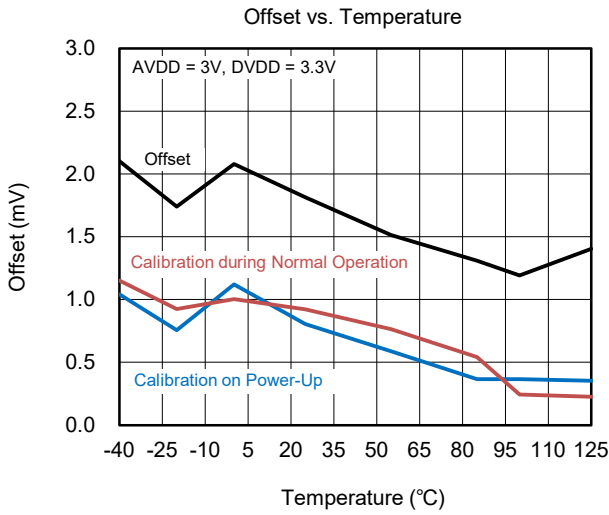

TYPICAL PERFORMANCE CHARACTERISTICS (continued)

T<sub>A</sub> = +25°C, AVDD = 3V, DVDD = 3.3V, and f<sub>SAMPLE</sub> = 2MSPS, unless otherwise noted.

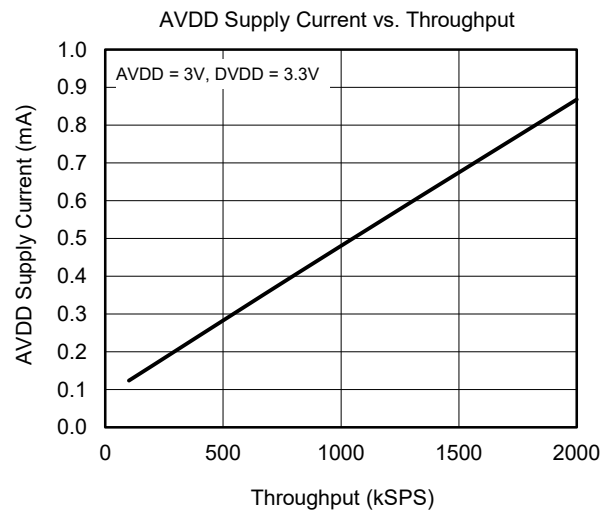
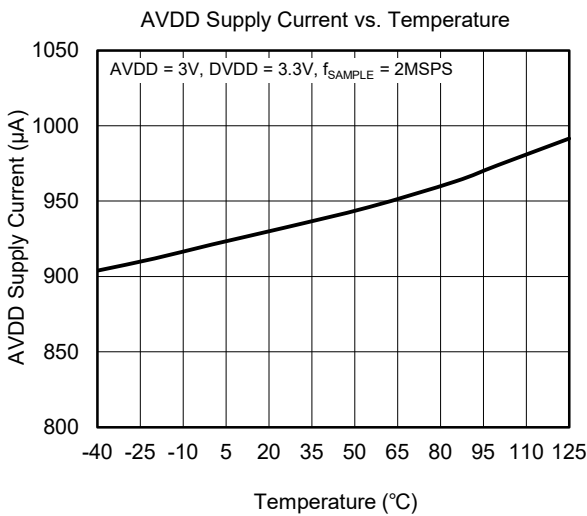
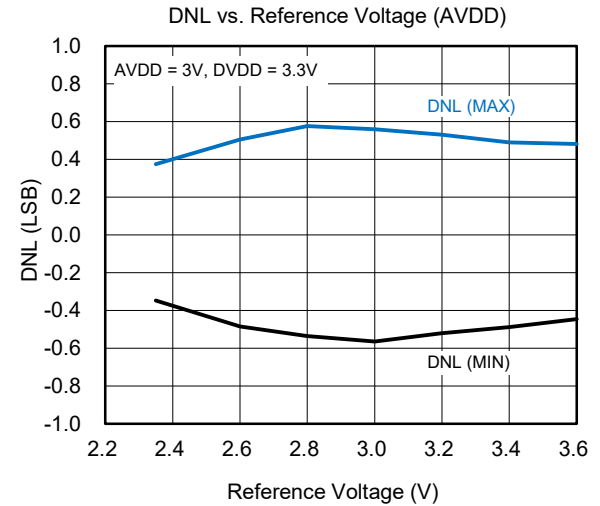
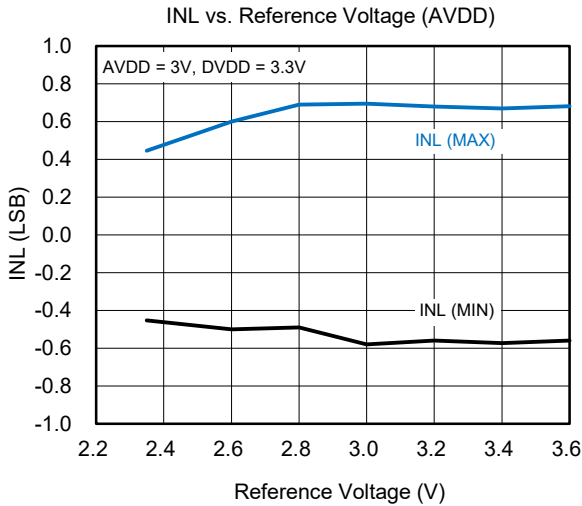
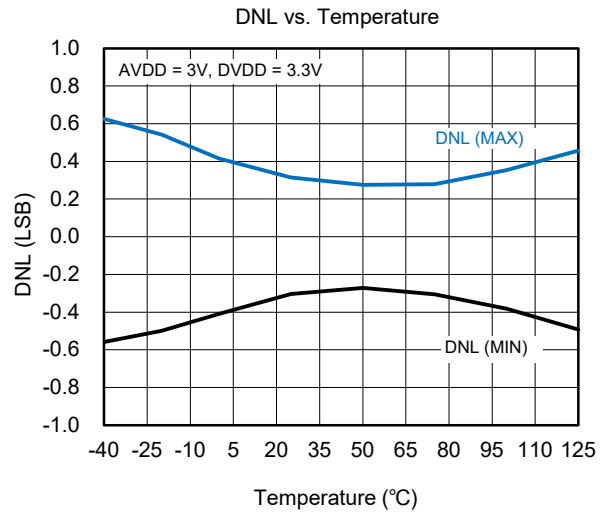
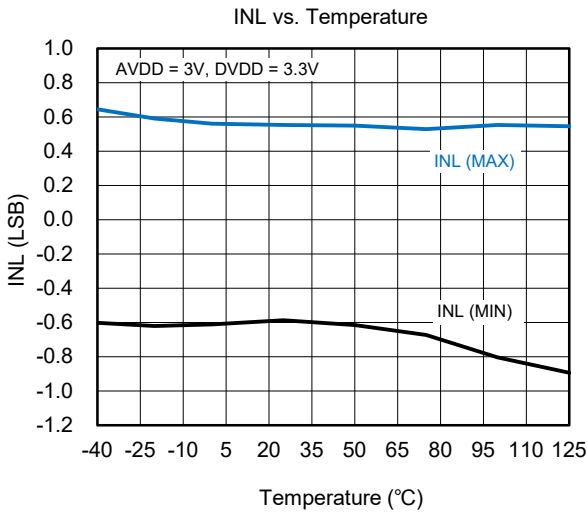

**TYPICAL PERFORMANCE CHARACTERISTICS (continued)**

$T_A = +25^\circ\text{C}$ ,  $AVDD = 3\text{V}$ ,  $DVDD = 3.3\text{V}$ , and  $f_{\text{SAMPLE}} = 2\text{MSPS}$ , unless otherwise noted.

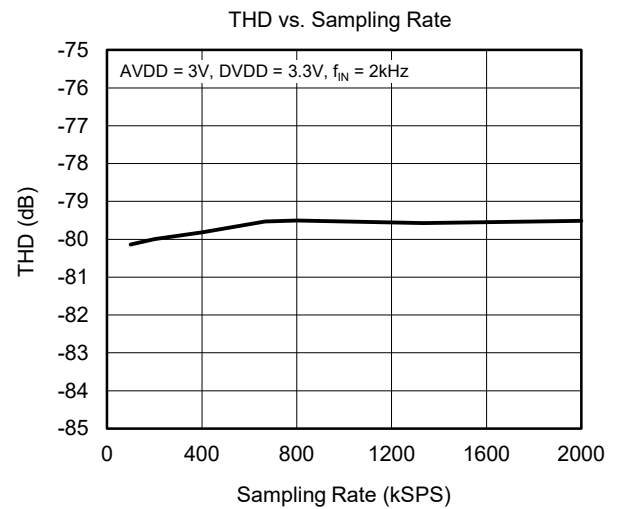
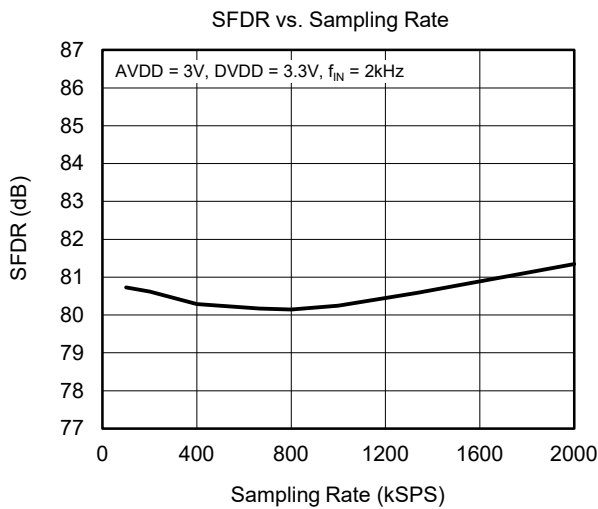
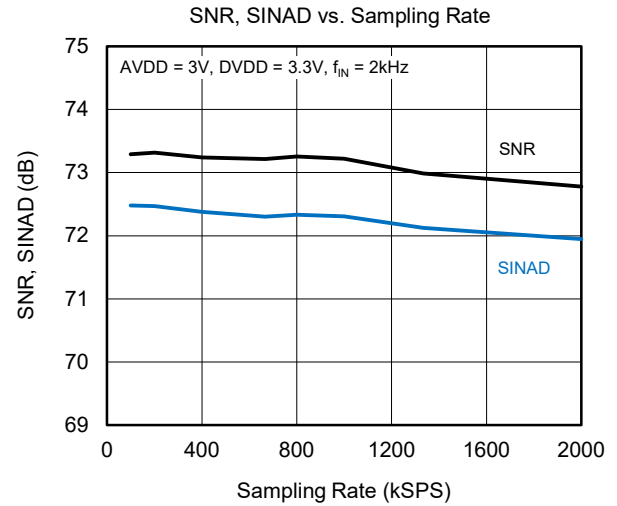
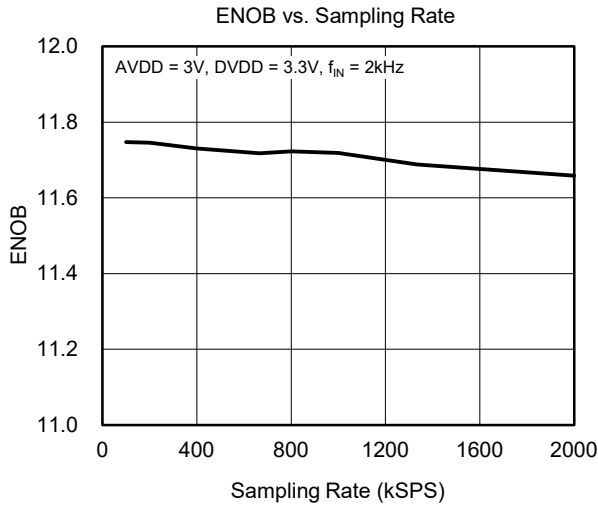
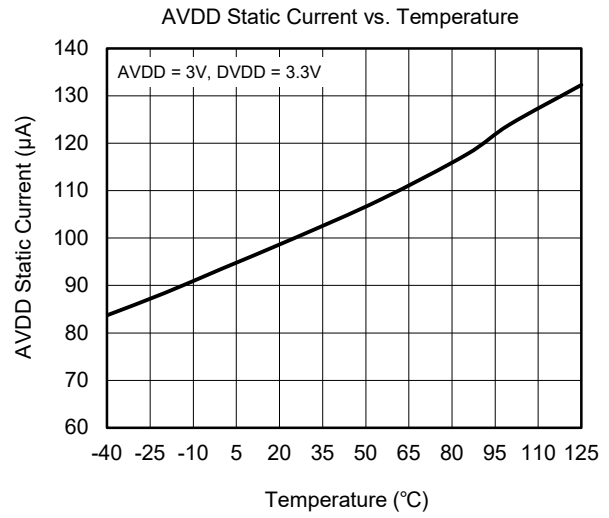
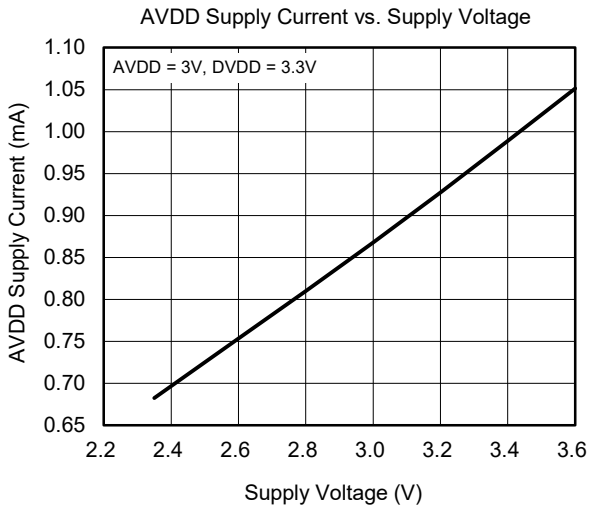

TYPICAL PERFORMANCE CHARACTERISTICS (continued)

T<sub>A</sub> = +25°C, AVDD = 3V, DVDD = 1.8V, and f<sub>SAMPLE</sub> = 2MSPS, unless otherwise noted.

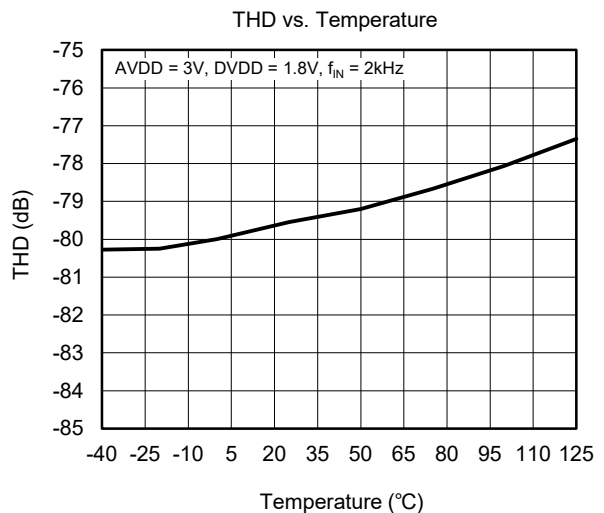
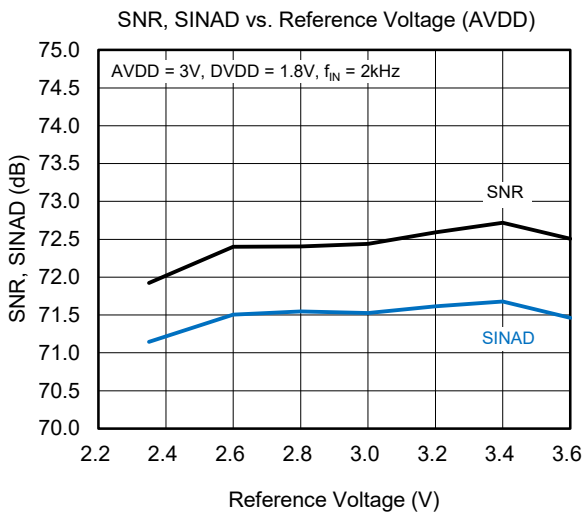
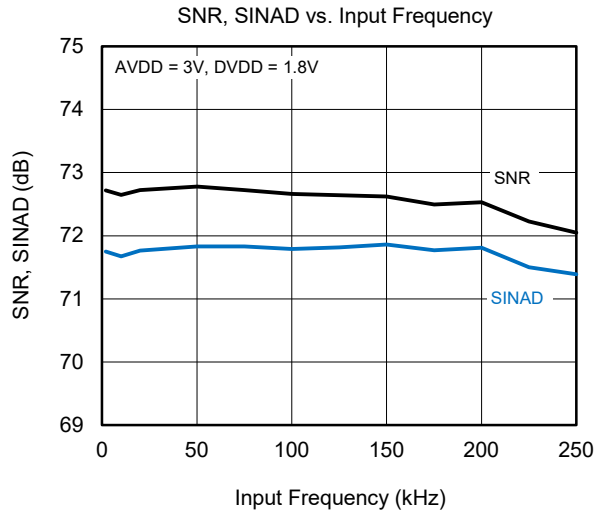
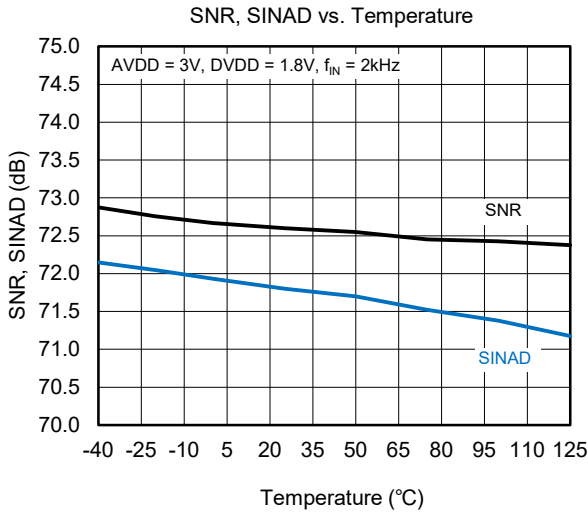
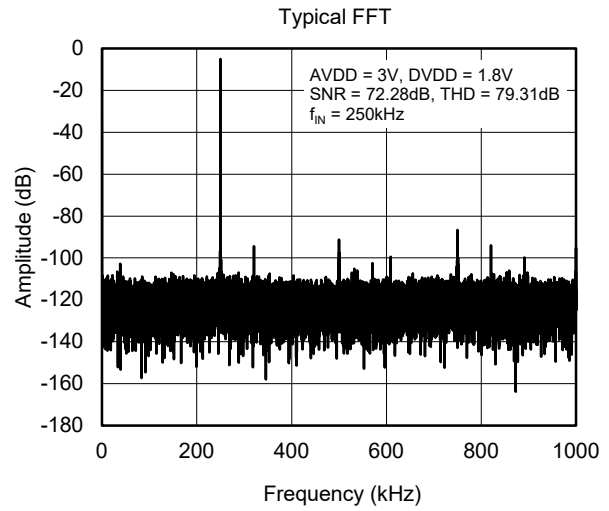
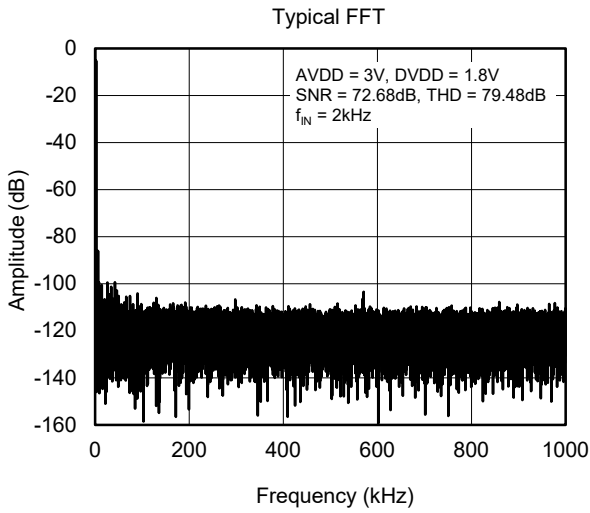

**TYPICAL PERFORMANCE CHARACTERISTICS (continued)**

$T_A = +25^\circ\text{C}$ ,  $AVDD = 3\text{V}$ ,  $DVDD = 1.8\text{V}$ , and  $f_{\text{SAMPLE}} = 2\text{MSPS}$ , unless otherwise noted.

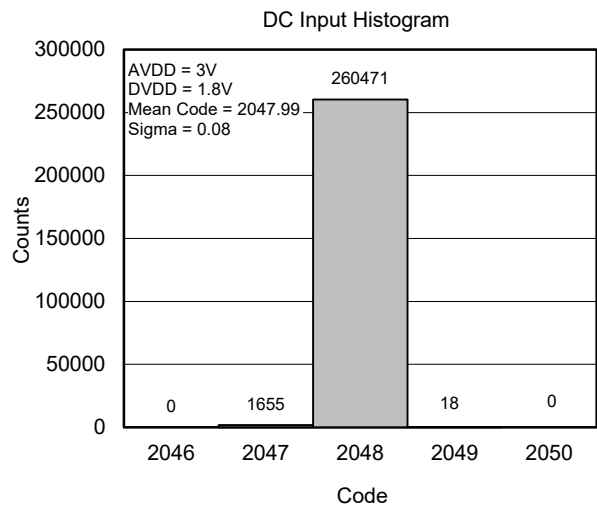
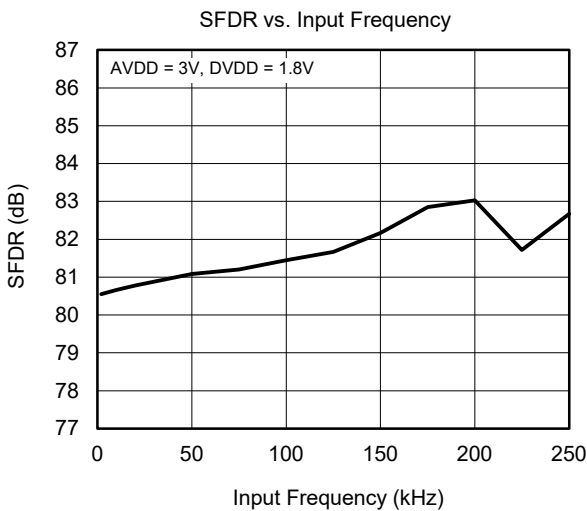
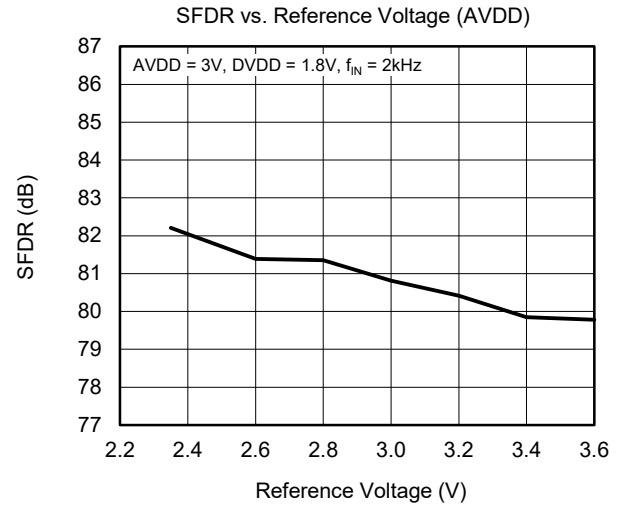
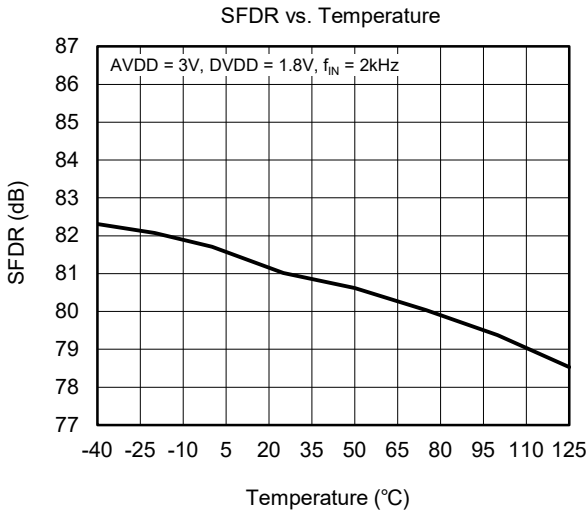
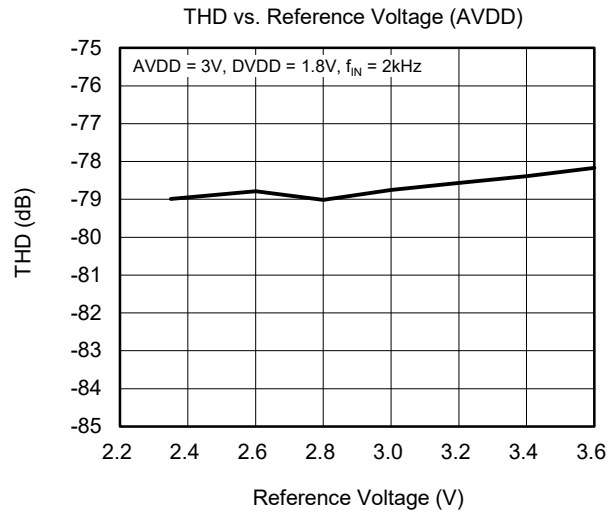
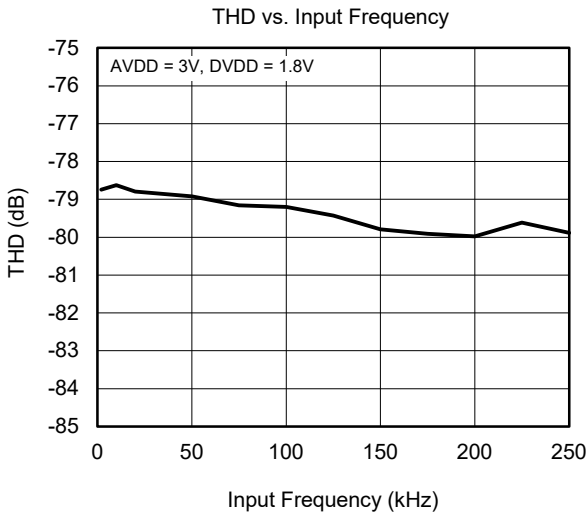

TYPICAL PERFORMANCE CHARACTERISTICS (continued)

T<sub>A</sub> = +25°C, AVDD = 3V, DVDD = 1.8V, and f<sub>SAMPLE</sub> = 2MSPS, unless otherwise noted.

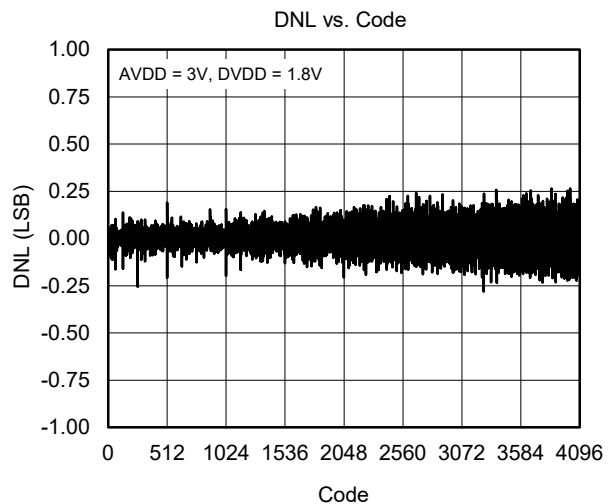
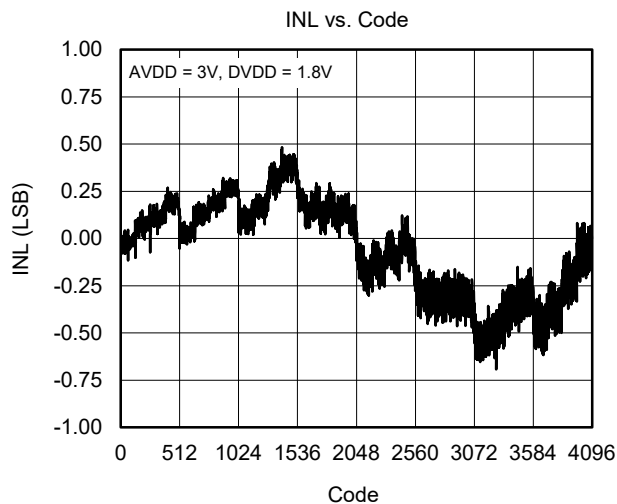
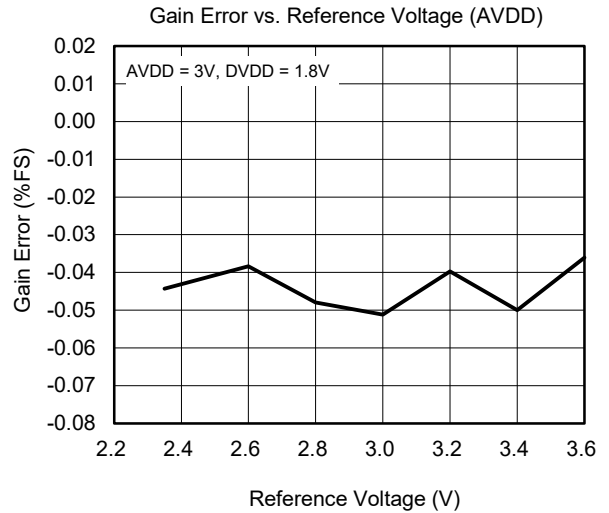
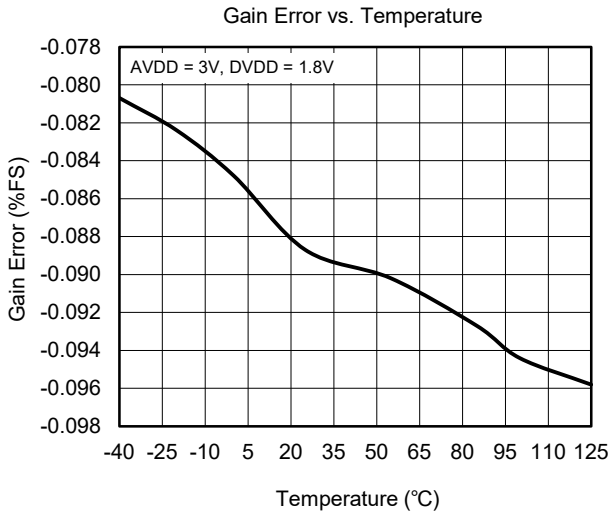
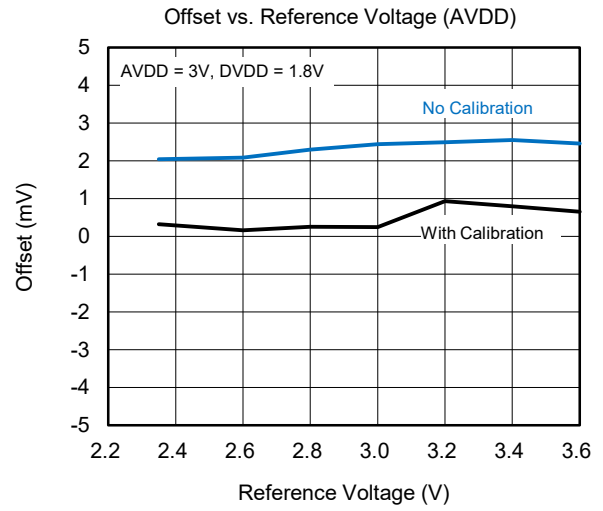
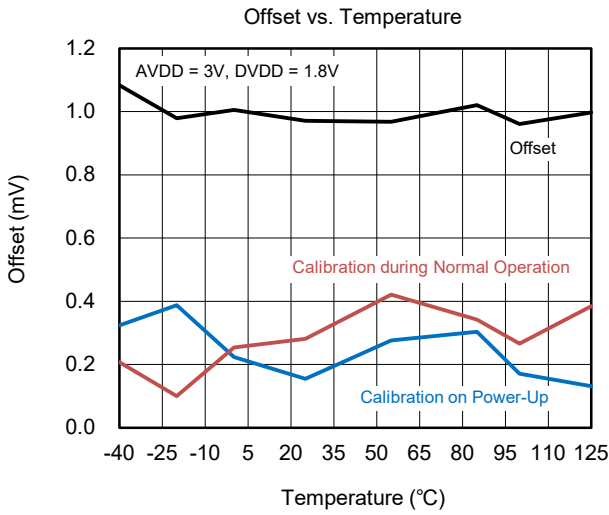

TYPICAL PERFORMANCE CHARACTERISTICS (continued)

T<sub>A</sub> = +25°C, AVDD = 3V, DVDD = 1.8V, and f<sub>SAMPLE</sub> = 2MSPS, unless otherwise noted.

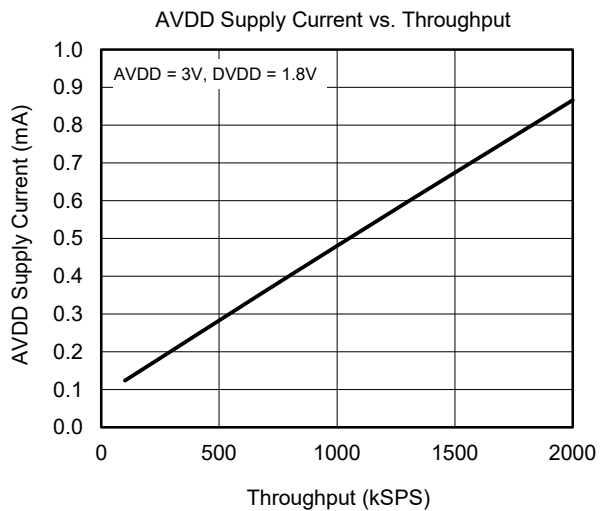
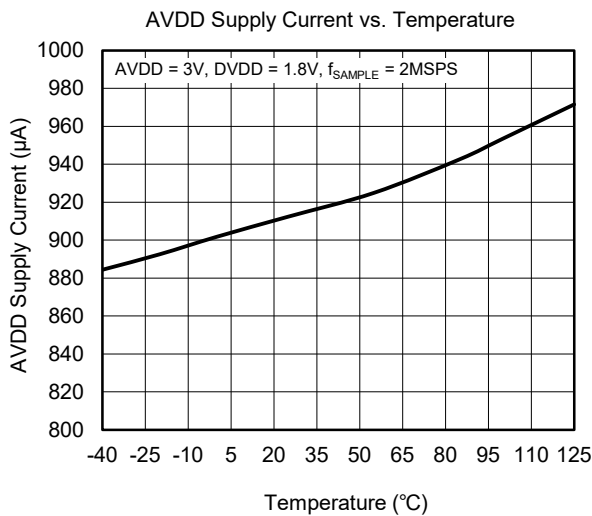
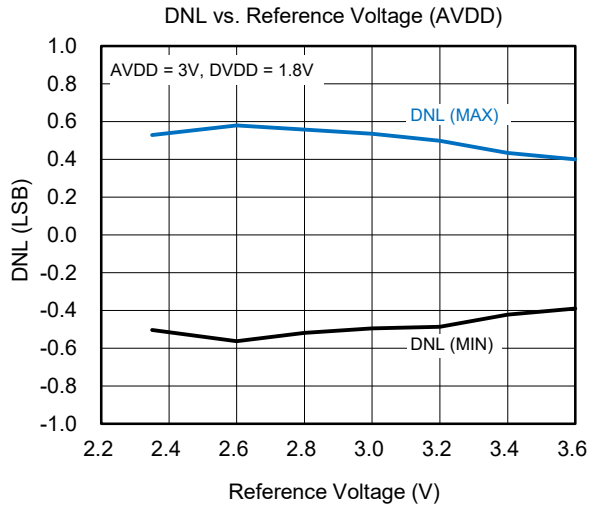
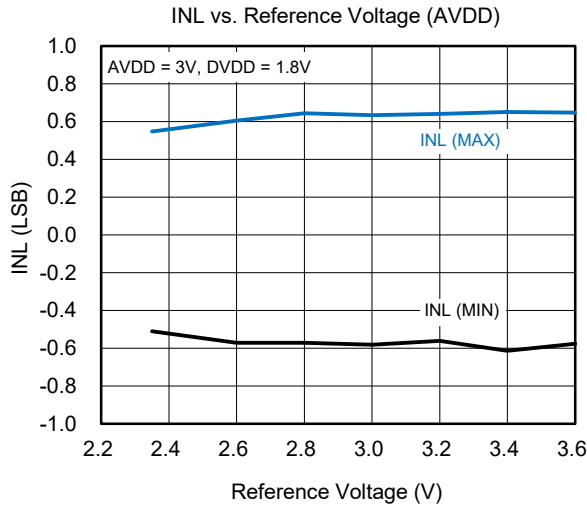
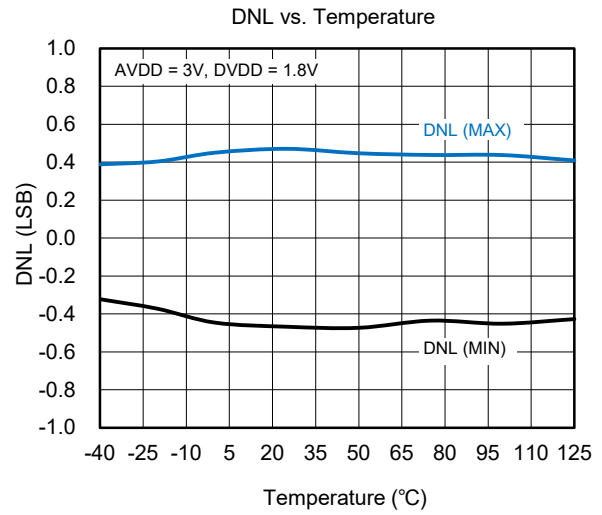
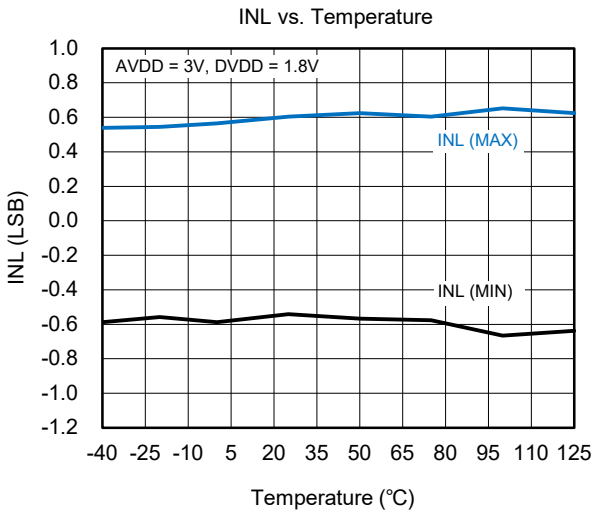

**TYPICAL PERFORMANCE CHARACTERISTICS (continued)**

$T_A = +25^\circ\text{C}$ ,  $AVDD = 3\text{V}$ ,  $DVDD = 1.8\text{V}$ , and  $f_{\text{SAMPLE}} = 2\text{MSPS}$ , unless otherwise noted.

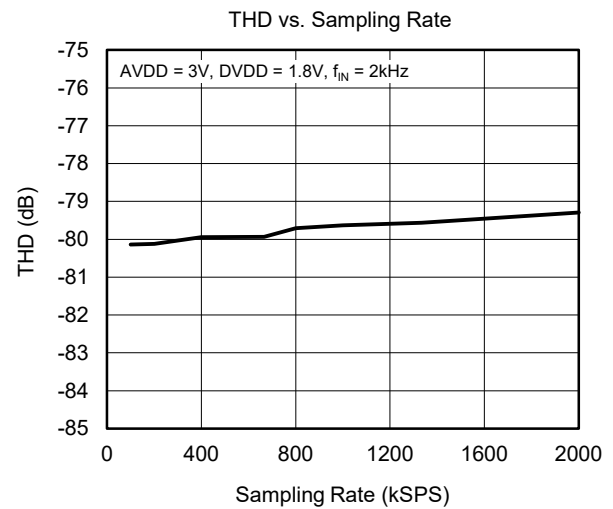
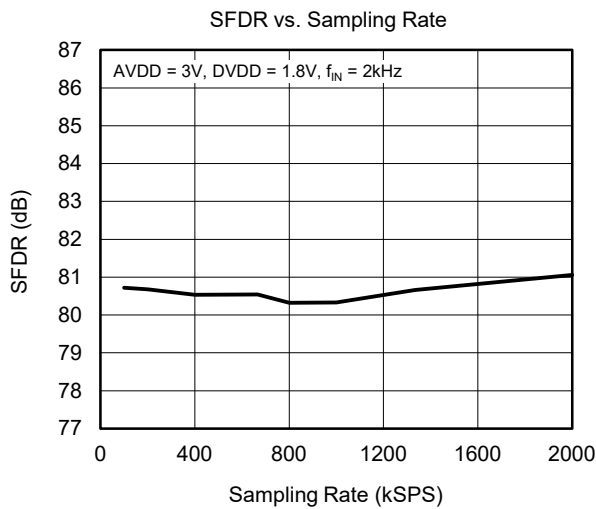
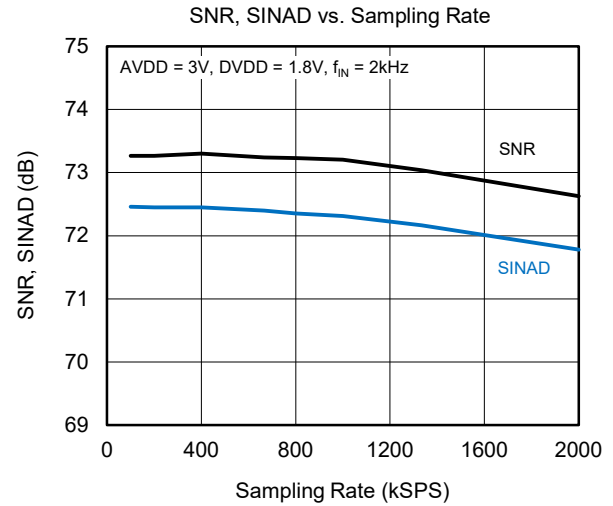
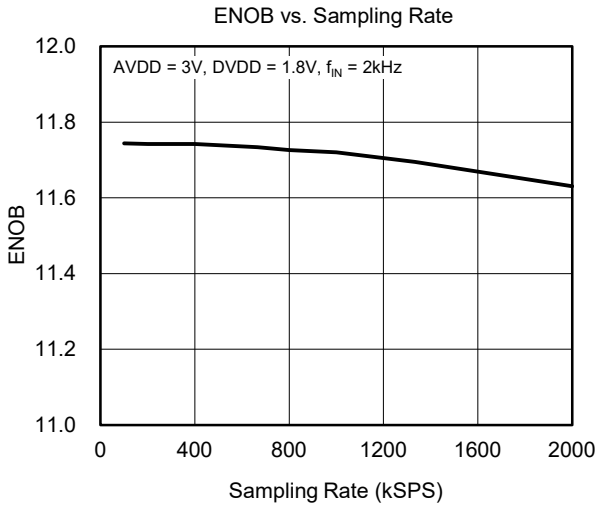
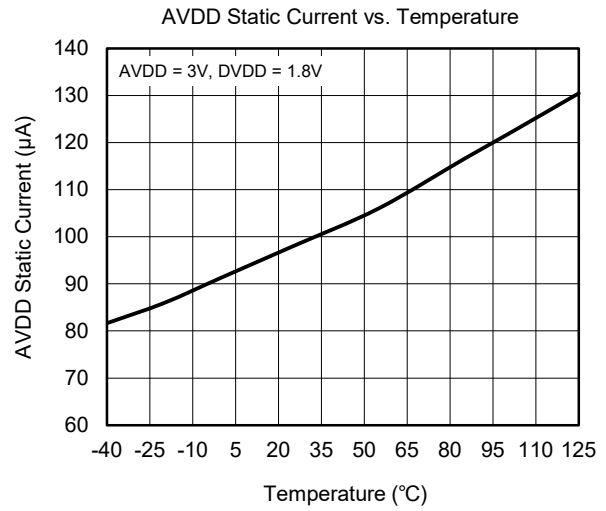
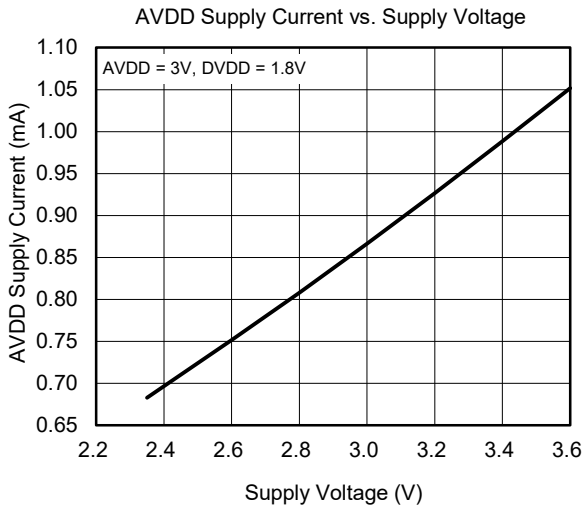



**TYPICAL APPLICATION CIRCUIT**

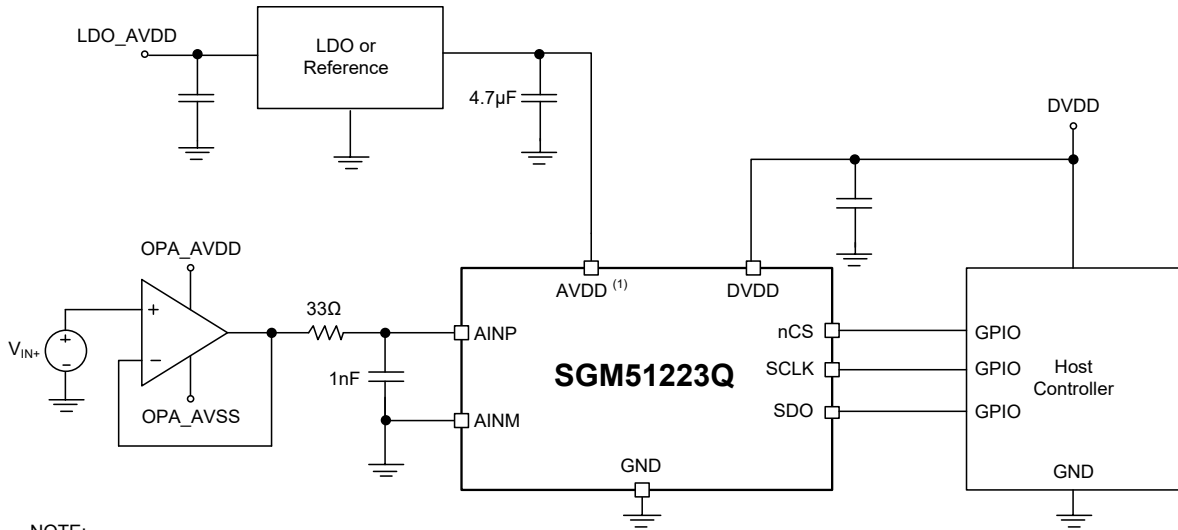

NOTE:  
1. AVDD is used as reference for the device.

**Figure 2. Typical Application Circuit**

**FUNCTIONAL BLOCK DIAGRAM**

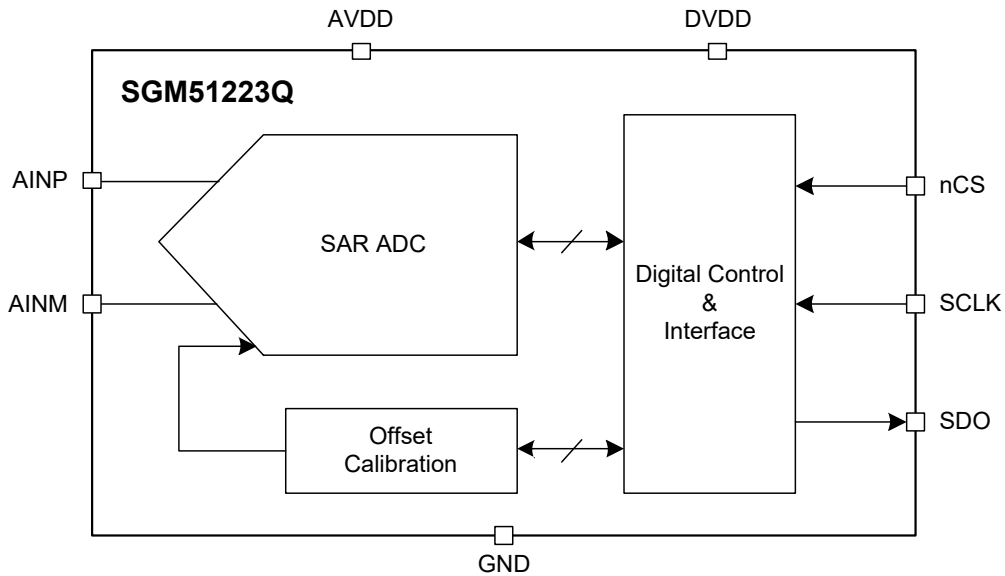

**Figure 3. Block Diagram**

DETAILED DESCRIPTION

Overview

The SGM51223Q is a low power easy-to-use SAR ADC.

The SGM51223Q doesn't have internal oscillator, and its conversion and data transfer are driven by an external clock on the SCLK pin. To run at 2MSPS through output, it needs a 32MHz SCLK input.

The SGM51223Q features an offset calibration function. It can be performed either after power-up or during normal working. Refer to the Offset Calibration section for details.

Reference

The SGM51223Q doesn't have a separate reference input pin, neither have an internal reference. The AVDD pin is the analog power supply pin and also the ADC reference voltage input pin. A low noise regulator or a low noise voltage reference source is recommended for this pin. A low equivalent series resistance (ESR) capacitor is recommended to be connected to this pin at the same time. The decoupling capacitor should be 3.3μF or 4.7μF.

The SGM51223Q full input range is equal to the voltage potential at the VDD pin.

Analog Input

The SGM51223Q supports single-ended input. It allows the AINM pin voltage potential to be in the range of -100mV to +100mV reference to GND pin of the device. And the AINP - AINM must be in the range from 0V to AVDD at the same time.

A typical equivalent input circuit is shown in Figure 4. The ideal transfer characteristics are shown in Figure 5 and Table 1.

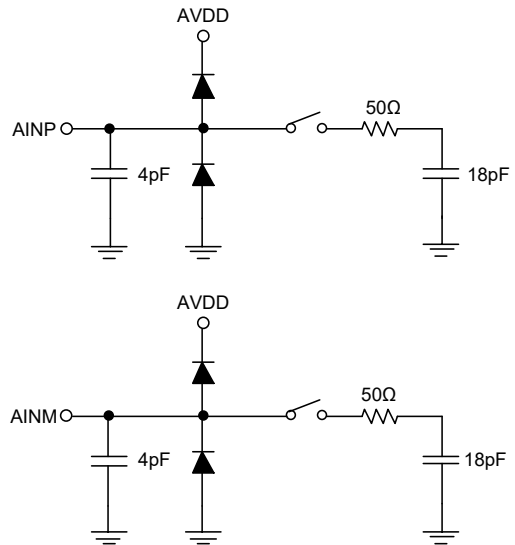

Figure 4. Equivalent Input Circuit for the Sampling Stage

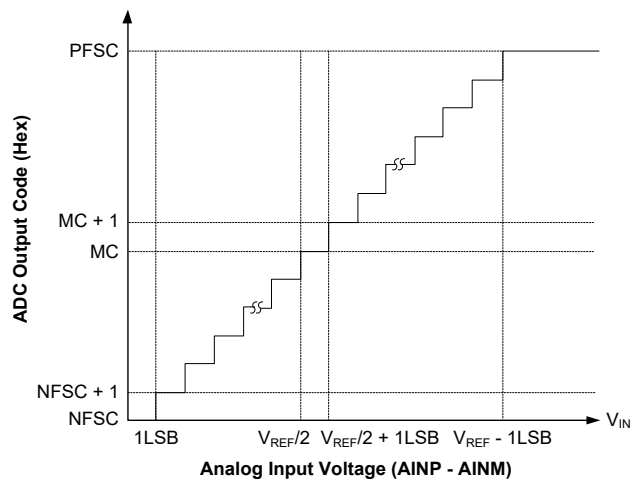

Figure 5. Ideal Transfer Characteristics

Table 1. Transfer Characteristics

| Analog Input Voltage (AINP - AINM)                                        | Code     | Description              | Ideal Output Code |
|---------------------------------------------------------------------------|----------|--------------------------|-------------------|
| $\leq 1\text{LSB}$                                                        | NFSC     | Negative full-scale code | 000h              |
| 1LSB to 2LSBs                                                             | NFSC + 1 | -                        | 001h              |
| $(V_{\text{REF}}/2)$ to $(V_{\text{REF}}/2) + 1\text{LSB}$                | MC       | Mid code                 | 800h              |
| $(V_{\text{REF}}/2) + 1\text{LSB}$ to $(V_{\text{REF}}/2) + 2\text{LSBs}$ | MC + 1   | -                        | 801h              |
| $\geq V_{\text{REF}} - 1\text{LSB}$                                       | PFSC     | Positive full-scale code | FFFh              |

DETAILED DESCRIPTION (continued)

Serial Interface

The SGM51223Q supports an SPI-compatible serial interface. The nCS is the data frame control signal. An operation data frame contains 14 clock falling edges. In the 14-bit data frame, the first data '0' is set by the falling edge of nCS, and the data from the 2<sup>nd</sup> bit to the 14<sup>th</sup> bit are set by the subsequent falling edges of the SCLKs. A rising edge of nCS stops the data frame. Figure 6 shows the serial interface timing diagram.

After power-up, the SGM51223Q will perform an offset calibration on the first operation frame. Refer to the Offset Calibration section for details.

Device Functional Modes  
Offset Calibration

The SGM51223Q can compensate the offset by setting an internal offset calibration register (OCR). The OCR default value is zero. In order to make the device work properly, it is suggested to perform offset calibration after the chip is

powered on, operating temperature changes significantly or power supply changes significantly.

During the offset calibration process, the input pins AINP and AINM are internally disconnected from the external connection, so it is not necessary to disconnect the ADC inputs from the external connection.

Offset Calibration on Power-Up

After the chip is powered up, the main host controller should issue a complete 32 SCLKs to perform offset calibration before the ADC conversion operation. If the 32 SCLKs of calibration are not provided enough, the OCR will not be updated on the following operation frame. During the calibration, the SDO output remains low. The timing parameters for the offset calibration on power-up are shown in Table 2. Figure 7 shows the offset calibration on power-up timing diagram.

Table 2. Offset Calibration on Power-Up

| PARAMETER                                   | SYMBOL             | MIN             | TYP | MAX | UNITS |
|---------------------------------------------|--------------------|-----------------|-----|-----|-------|
| SCLK Frequency for Calibration              | $f_{CLK\_CAL}$     |                 |     | 16  | MHz   |
| Calibration Time at Power-Up                | $t_{POWERUP\_CAL}$ | $32 \times t_6$ |     |     | ns    |
| Acquisition Time                            | $t_2$              | 90              |     |     | ns    |
| nCS High Time                               | $t_7$              | $t_{ACQ}$       |     |     | ns    |
| Setup Time: nCS Falling to SCLK Falling     | $t_3$              | 12              |     |     | ns    |
| Delay Time: Last SCLK Falling to nCS Rising | $t_8$              | 10              |     |     | ns    |

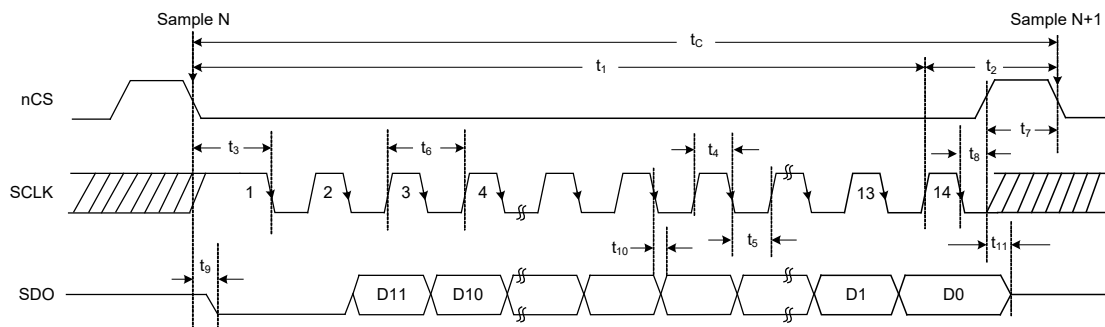

Figure 6. Serial Interface Timing Diagram

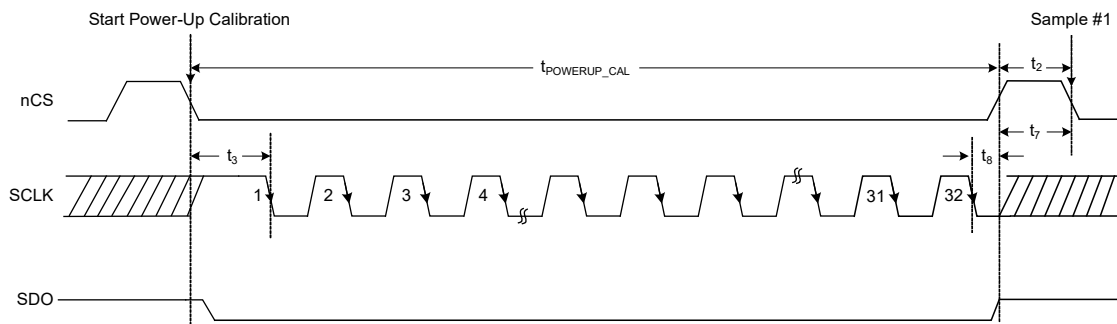

Figure 7. Offset Calibration on Power-Up Timing Diagram

**DETAILED DESCRIPTION (continued)**

**Offset Calibration during Normal Operation**

The offset calibration can also be performed during the ADC normal operation. Similar as the calibration on power-up, it will take 32 SCLKs to complete the offset calibration during ADC normal operation. During the calibration, for the first 14 SCLKs, the chip will output normal conversion results on the SDO pin. The calibration is performed between the 17<sup>th</sup> and

32<sup>nd</sup> SCLKs. The SDO output will remain low after the 14<sup>th</sup> SCLK. If the 32 SCLKs of calibration are not provided enough, the OCR will not be updated on the following operation frame. The timing parameters for the offset calibration during normal operation are shown in Table 3. Figure 8 shows the offset calibration during normal operation timing diagram.

**Table 3. Offset Calibration during Normal Operation**

| PARAMETER                                   | SYMBOL         | MIN             | TYP | MAX | UNITS |
|---------------------------------------------|----------------|-----------------|-----|-----|-------|
| SCLK Frequency for Calibration              | $f_{CLK\_CAL}$ |                 |     | 16  | MHz   |
| Calibration Time during Normal Operation    | $t_{CAL}$      | $15 \times t_6$ |     |     | ns    |
| Acquisition Time                            | $t_2$          | 90              |     |     | ns    |
| nCS High Time                               | $t_7$          | $t_{ACQ}$       |     |     | ns    |
| Setup Time: nCS Falling to SCLK Falling     | $t_3$          | 12              |     |     | ns    |
| Delay Time: Last SCLK Falling to nCS Rising | $t_8$          | 10              |     |     | ns    |

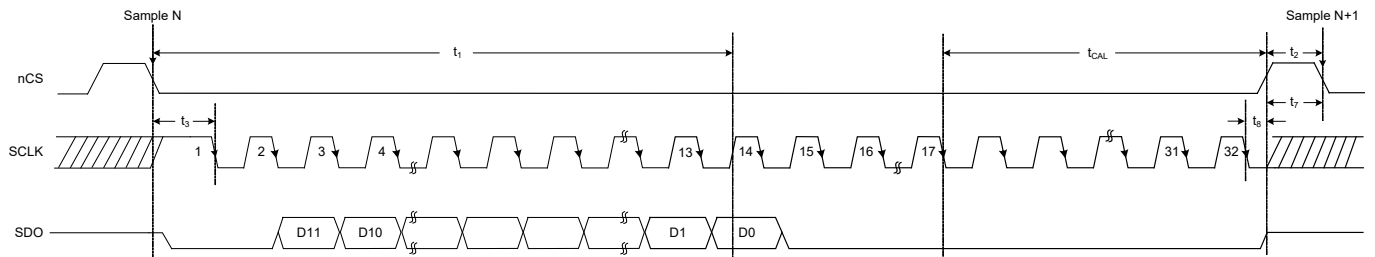

**Figure 8. Offset Calibration during Normal Operation Timing Diagram**

**REVISION HISTORY**

NOTE: Page numbers for previous revisions may differ from page numbers in the current version.

| Changes from Original (MARCH 2025) to REV.A          | Page |
|------------------------------------------------------|------|
| Changed from product preview to production data..... | All  |

PACKAGE OUTLINE DIMENSIONS

VSSOP-8

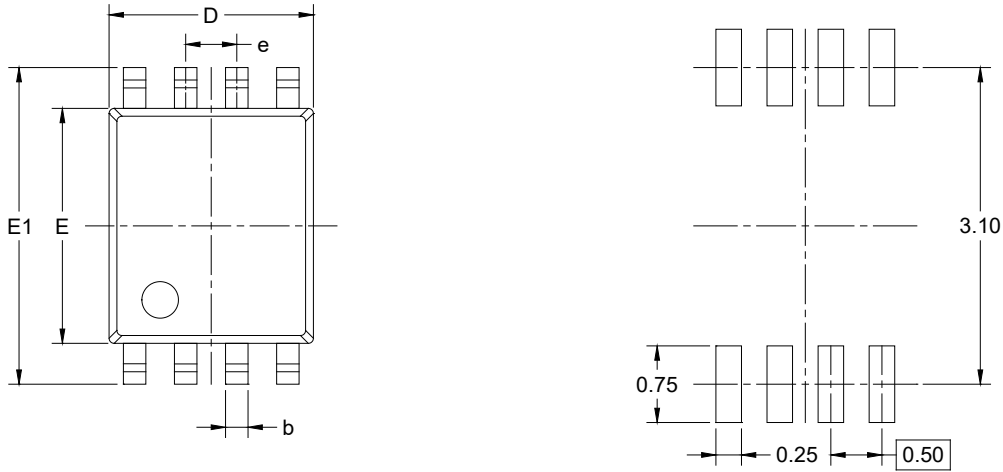

RECOMMENDED LAND PATTERN (Unit: mm)

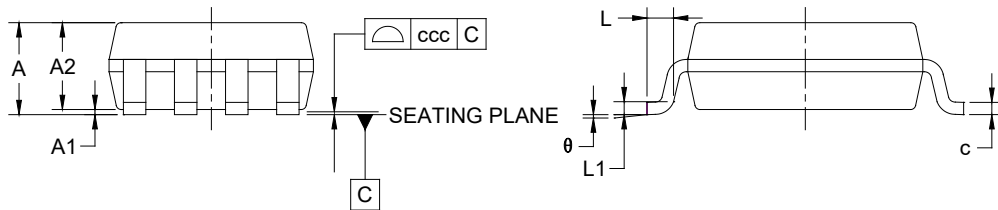

| Symbol | Dimensions In Millimeters |     |       |
|--------|---------------------------|-----|-------|
|        | MIN                       | NOM | MAX   |
| A      | -                         | -   | 1.000 |
| A1     | 0.000                     | -   | 0.150 |
| A2     | 0.600                     | -   | 0.850 |
| b      | 0.170                     | -   | 0.270 |
| c      | 0.080                     | -   | 0.230 |
| D      | 1.900                     | -   | 2.100 |
| E      | 2.200                     | -   | 2.400 |
| E1     | 3.000                     | -   | 3.200 |
| e      | 0.500 BSC                 |     |       |
| L      | 0.150                     | -   | 0.400 |
| L1     | 0.120 BSC                 |     |       |
| θ      | 0°                        | -   | 8°    |
| ccc    | 0.100                     |     |       |

NOTES:

1. This drawing is subject to change without notice.
2. The dimensions do not include mold flashes, protrusions or gate burrs.
3. Reference JEDEC MO-187 CA.

TAPE AND REEL INFORMATION

REEL DIMENSIONS

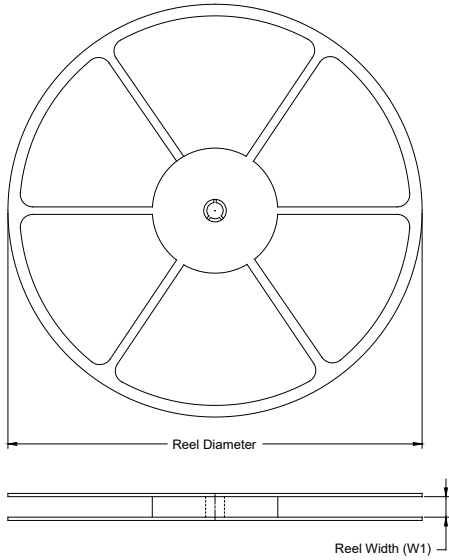

TAPE DIMENSIONS

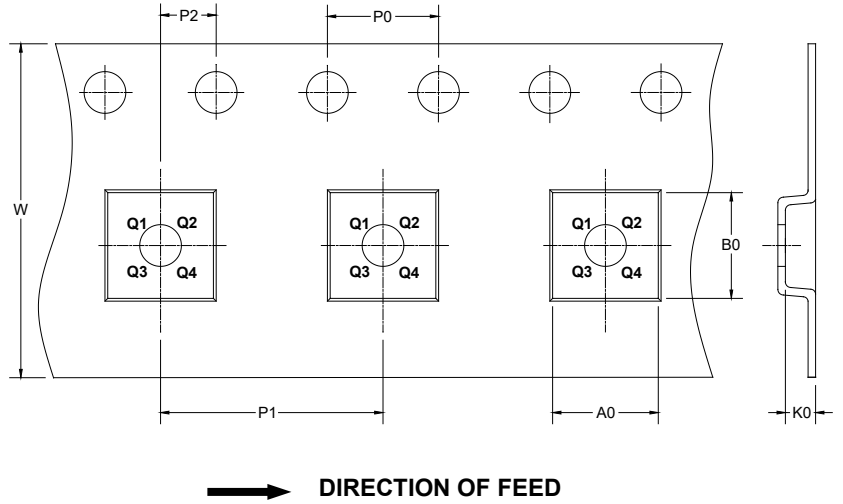

NOTE: The picture is only for reference. Please make the object as the standard.

KEY PARAMETER LIST OF TAPE AND REEL

| Package Type | Reel Diameter | Reel Width W1 (mm) | A0 (mm) | B0 (mm) | K0 (mm) | P0 (mm) | P1 (mm) | P2 (mm) | W (mm) | Pin1 Quadrant |
|--------------|---------------|--------------------|---------|---------|---------|---------|---------|---------|--------|---------------|
| VSSOP-8      | 7"            | 9.5                | 2.25    | 3.35    | 1.05    | 4.0     | 4.0     | 2.0     | 8.0    | Q3            |

DD0001

# PACKAGE INFORMATION

## CARTON BOX DIMENSIONS

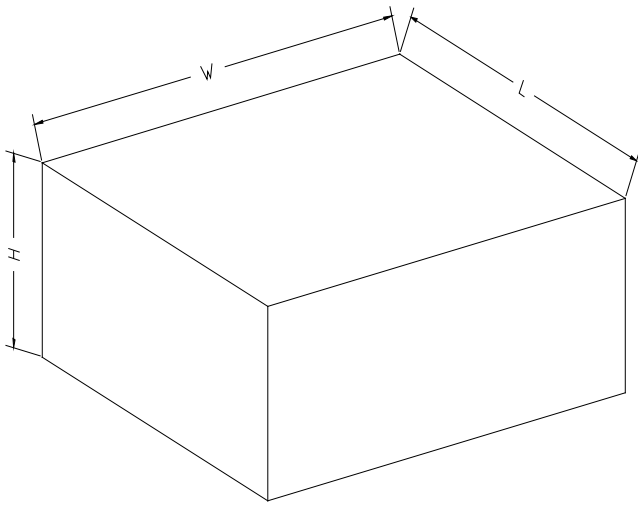

NOTE: The picture is only for reference. Please make the object as the standard.

## KEY PARAMETER LIST OF CARTON BOX

| Reel Type   | Length (mm) | Width (mm) | Height (mm) | Pizza/Carton |
|-------------|-------------|------------|-------------|--------------|
| 7" (Option) | 368         | 227        | 224         | 8            |
| 7"          | 442         | 410        | 224         | 18           |

DD0002