

GENERAL DESCRIPTION

The SGM2595D is a single channel power distribution switch. The switch controlled by the EN pin operates from 2.5V to 6V supply voltage. It can be used in USB power distribution applications.

The SGM2595D has integrated current limit function to protect the upstream power supply from damage during over-current or short-circuit condition. It also has the function of over-temperature protection.

The device is designed with soft-start circuit to cope with inrush currents when large capacitive loads are connected. The nFAULT output will be asserted to low level during over-current, over-temperature or reverse voltage condition.

The SGM2595D further reduces the total solution size by integrating a 47Ω pull-down resistor for output discharge when the switch is shut down by EN.

The SGM2595D is available in Green MSOP-8 and SOT-23-5 packages.

FEATURES

- High-side N-MOSFET
- On-Resistance: 65mΩ (TYP)
- Current Limit Threshold: 2905mA
- Input Voltage Range: 2.5V to 6V
- Quiescent Current: 27μA (TYP)
- Shutdown Current: 0.29μA (TYP)
- Soft-Start Function
- Over-Temperature Protection
- Under-Voltage Lockout Protection for VIN
- No Reversed Leakage Current (Reverse Blocking)
- Fault Flag (nFAULT Pin)
- Quick Output Discharge
- 1.2MΩ Pull-Down Resistor at EN Pin
- Available in Green MSOP-8 and SOT-23-5 Packages

APPLICATIONS

General Purpose Power Switching
 USB Bus/Self-Powered Hub
 USB Peripheral
 ACPI Power Distribution
 Smart Phone
 LCD TV

TYPICAL APPLICATION

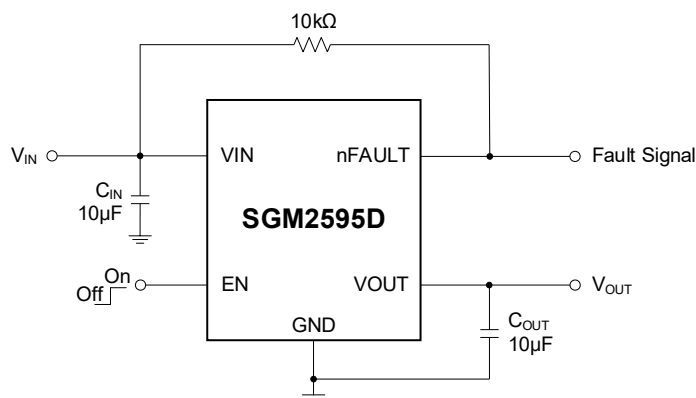

Figure 1. Typical Application Circuit

PACKAGE/ORDERING INFORMATION

MODEL	PACKAGE DESCRIPTION	SPECIFIED TEMPERATURE RANGE	ORDERING NUMBER	PACKAGE MARKING	PACKING OPTION
SGM2595D	MSOP-8	-40°C to +125°C	SGM2595DXMS8G/TR	SGM0FL XMS8 XXXXX	Tape and Reel, 4000
	SOT-23-5	-40°C to +125°C	SGM2595DXN5G/TR	0FKXX	Tape and Reel, 4000

MARKING INFORMATION

NOTE: XXXXX = Date Code, Trace Code and Vendor Code. XX = Date Code.

MSOP-8

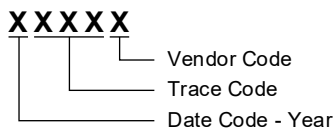

SOT-23-5

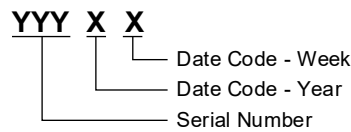

Green (RoHS & HSF): SG Micro Corp defines "Green" to mean Pb-Free (RoHS compatible) and free of halogen substances. If you have additional comments or questions, please contact your SGMICRO representative directly.

ABSOLUTE MAXIMUM RATINGS

VIN.....	6.5V
All Other Pins.....	6V
nFAULT Current	25mA
Package Thermal Resistance	
MSOP-8, θ_{JA}	155.4°C/W
MSOP-8, θ_{JB}	99.1°C/W
MSOP-8, θ_{JC}	61.7°C/W
SOT-23-5, θ_{JA}	171.1°C/W
SOT-23-5, θ_{JA}	37.8°C/W
SOT-23-5, θ_{JA}	61.1°C/W
Junction Temperature.....	+150°C
Storage Temperature Range	-65°C to +150°C
Lead Temperature (Soldering, 10s).....	+260°C
ESD Susceptibility	
HBM.....	2000V
CDM	1000V

RECOMMENDED OPERATING CONDITIONS

Input Voltage Range	2.5V to 6V
EN Voltage Range	-0.3V to 5.5V
All Other Pins.....	0V to 5.5V
Operating Junction Temperature Range.....	-40°C to +125°C

OVERSTRESS CAUTION

Stresses beyond those listed in Absolute Maximum Ratings may cause permanent damage to the device. Exposure to absolute maximum rating conditions for extended periods may affect reliability. Functional operation of the device at any conditions beyond those indicated in the Recommended Operating Conditions section is not implied.

ESD SENSITIVITY CAUTION

This integrated circuit can be damaged if ESD protections are not considered carefully. SGMICRO recommends that all integrated circuits be handled with appropriate precautions. Failure to observe proper handling and installation procedures can cause damage. ESD damage can range from subtle performance degradation to complete device failure. Precision integrated circuits may be more susceptible to damage because even small parametric changes could cause the device not to meet the published specifications.

DISCLAIMER

SG Micro Corp reserves the right to make any change in circuit design, or specifications without prior notice.

PIN CONFIGURATIONS

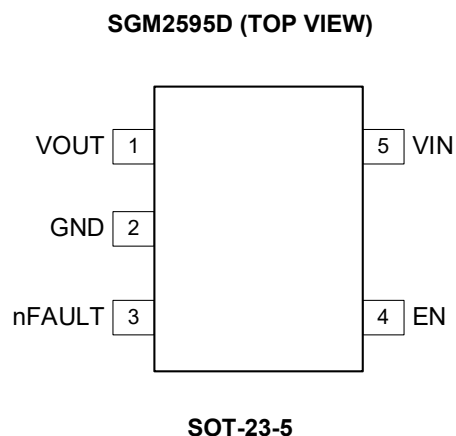
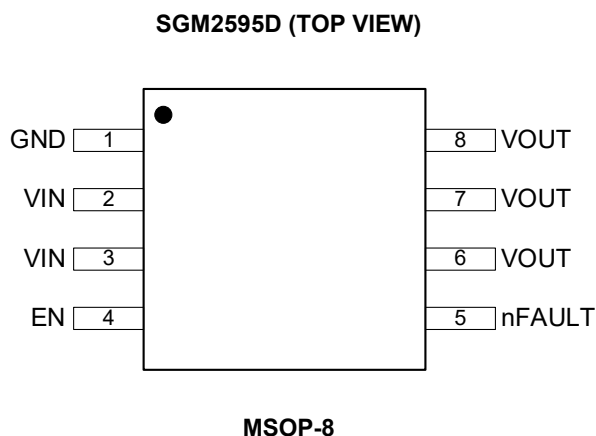

PIN DESCRIPTION

PIN		NAME	FUNCTION
MSOP-8	SOT-23-5		
1	2	GND	Ground.
2, 3	5	VIN	Power Input Voltage.
4	4	EN	Chip Enable. Active-high for SGM2595D. It has integrated a 1.2MΩ pull-down resistor at this pin.
5	3	nFAULT	Active-Low Open-Drain Output. It is asserted during over-current, over-temperature or reverse voltage condition.
6, 7, 8	1	VOUT	Output Voltage.

ELECTRICAL CHARACTERISTICS

(T_J = -40°C to +125°C, typical values are at T_J = +25°C, V_{IN} = 5V, unless otherwise noted.)

PARAMETER	SYMBOL	CONDITIONS	MIN	TYP	MAX	UNITS
Input Voltage Range	V _{IN}		2.5		6	V
Under-Voltage Lockout Threshold	V _{UVLO}	V _{IN} rising		2.22	2.40	V
Under-Voltage Lockout Threshold Hysteresis	V _{UVLO_HYS}	V _{IN} falling		100		mV
Quiescent Current	I _Q	Switch on, V _{OUT} = open		27	60	μA
Shutdown Current	I _{SD}	Switch off, V _{OUT} = open		0.29	5	μA
Output Leakage Current	I _{LEAKAGE}	Switch off, V _{OUT} = 6V, V _{IN} = 0V, T _J = -40°C to +85°C		0.22	1.5	μA
		Switch off, V _{OUT} = 6V, V _{IN} = 0V, T _J = -40°C to +125°C		0.22	6	
Enable Input Threshold	V _{IH}		1.2			V
	V _{IL}	T _J = -40°C to +85°C			0.4	
		T _J = -40°C to +125°C			0.3	
Pull-Down Resistor at EN Pin	R _{PULL_DOWN}			1.2		MΩ
On-Resistance	R _{DSON_MSOP}	I _{OUT} = 200mA	T _J = -40°C to +85°C	65	98	mΩ
			T _J = -40°C to +125°C	65	125	
	R _{DSON_SOT-23-5}		T _J = -40°C to +85°C	65	98	
	T _J = -40°C to +125°C		65	125		
Output Turn-On Delay Time	t _{ON}	R _L = 100Ω, C _{OUT} = 0.1μF		1.1		ms
Output Turn-Off Delay Time	t _{OFF}	R _L = 100Ω, C _{OUT} = 0.1μF		27		μs
Output Turn-On Rise Time	t _R	R _L = 100Ω, C _{OUT} = 0.1μF		1.3		ms
Output Turn-Off Fall Time	t _F	R _L = 100Ω, C _{OUT} = 0.1μF		14		μs
Over-Current nFAULT Response Delay Time	t _D	Force the chip into current limit mode		15		ms
Reverse nFAULT Response Delay Time	t _{D_REV}			3		ms
Current Limit Threshold	I _{LIM}	T _J = +25°C	2660	2905	3170	mA
		T _J = -40°C to +125°C	2590	2905	3215	
Short-Circuit Current Limit ⁽¹⁾	I _{SHORT}	Enabled, output short to ground	1460	1725	2100	mA
Reverse Protection Threshold	V _{REV}	V _{OUT} rising	7	24	39	mV
Reverse Protection Threshold Hysteresis	V _{REV_HYS}	V _{OUT} falling		16		mV
nFAULT Output Resistance	R _{nFAULT}	nFAULT is low and I _{SINK} = 10mA		20		Ω
nFAULT Leakage Current	I _{nFAULT}	nFAULT is high		1		nA
VO _{UT} Shutdown Discharge Resistance	R _{DIS}	Switch off, sink 2mA into OUT		47		Ω
Thermal Shutdown Temperature	T _{SD}	T _J increasing, no load		156		°C
Thermal Shutdown Hysteresis	T _{HYS}			55		°C

NOTE:

1. Guaranteed by design, not tested in production.

TYPICAL PERFORMANCE CHARACTERISTICS

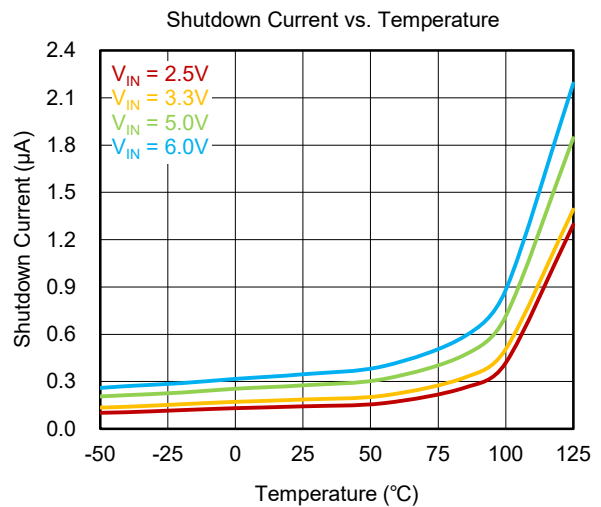
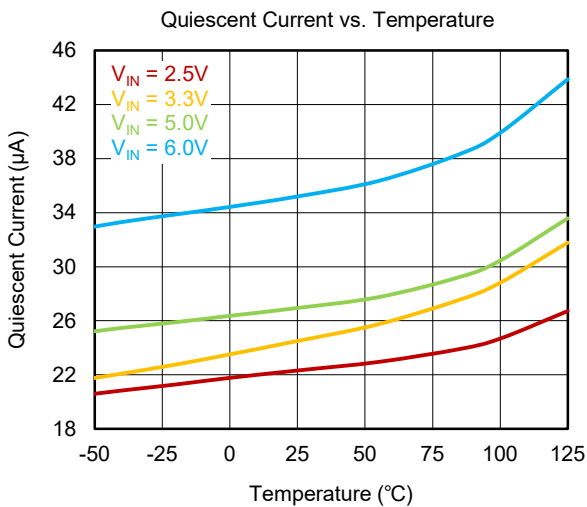
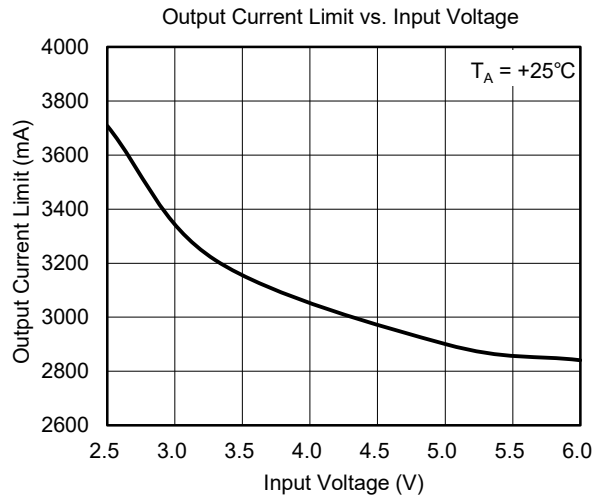
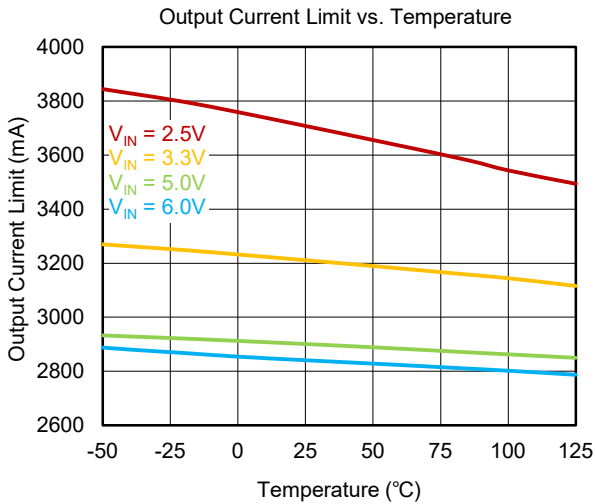
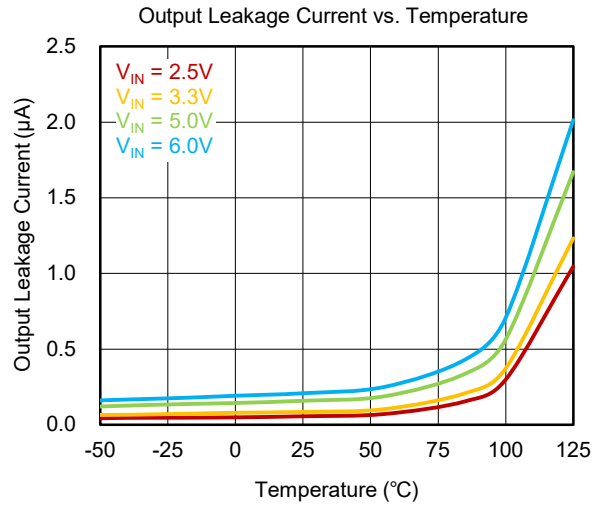
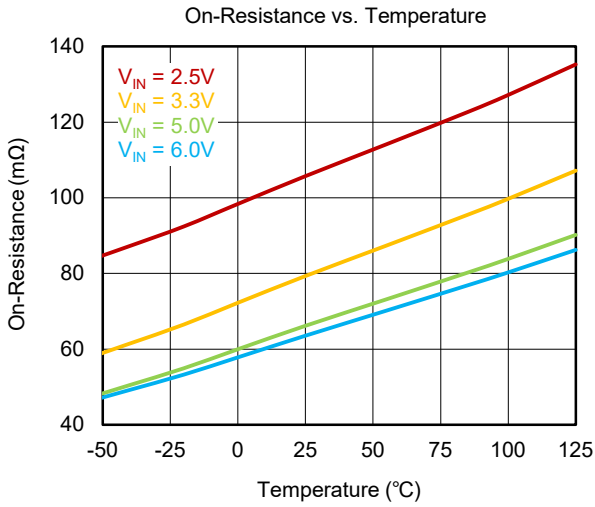

TYPICAL PERFORMANCE CHARACTERISTICS (continued)

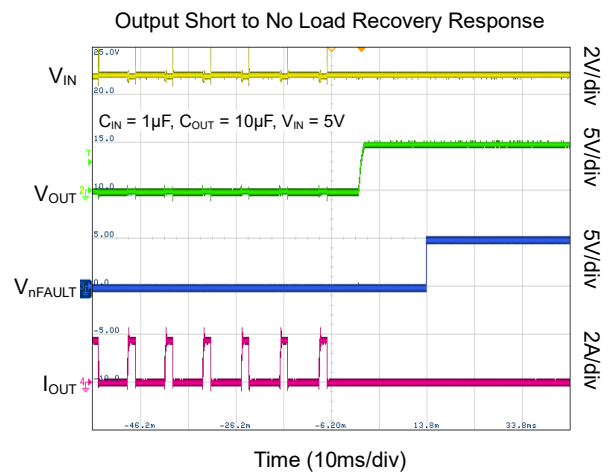
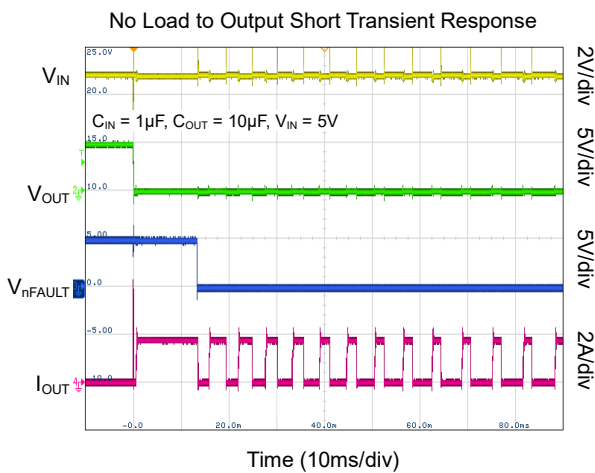
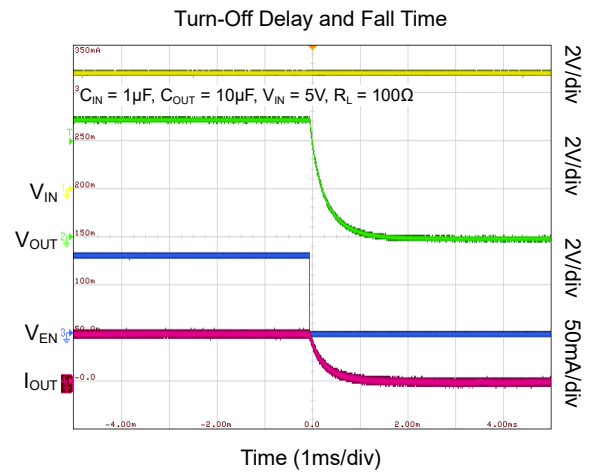
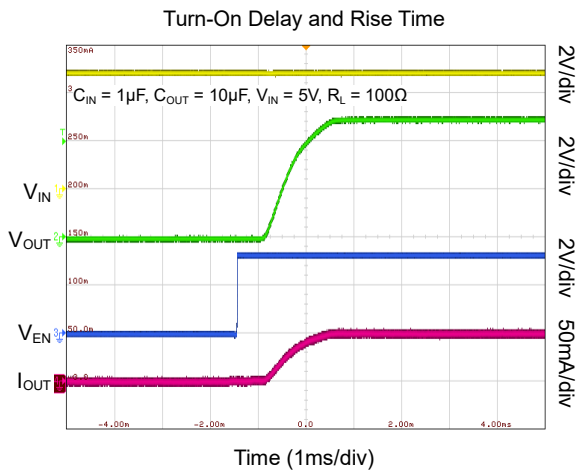
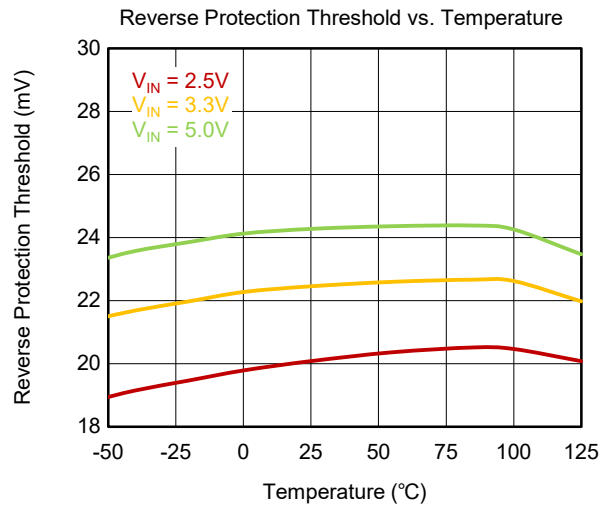
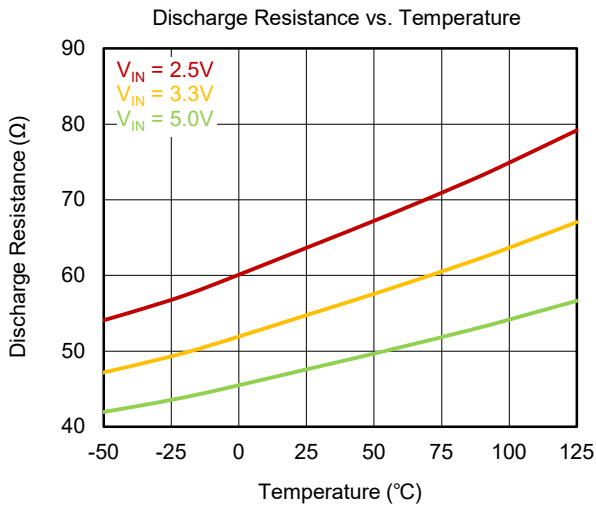

FUNCTIONAL BLOCK DIAGRAM

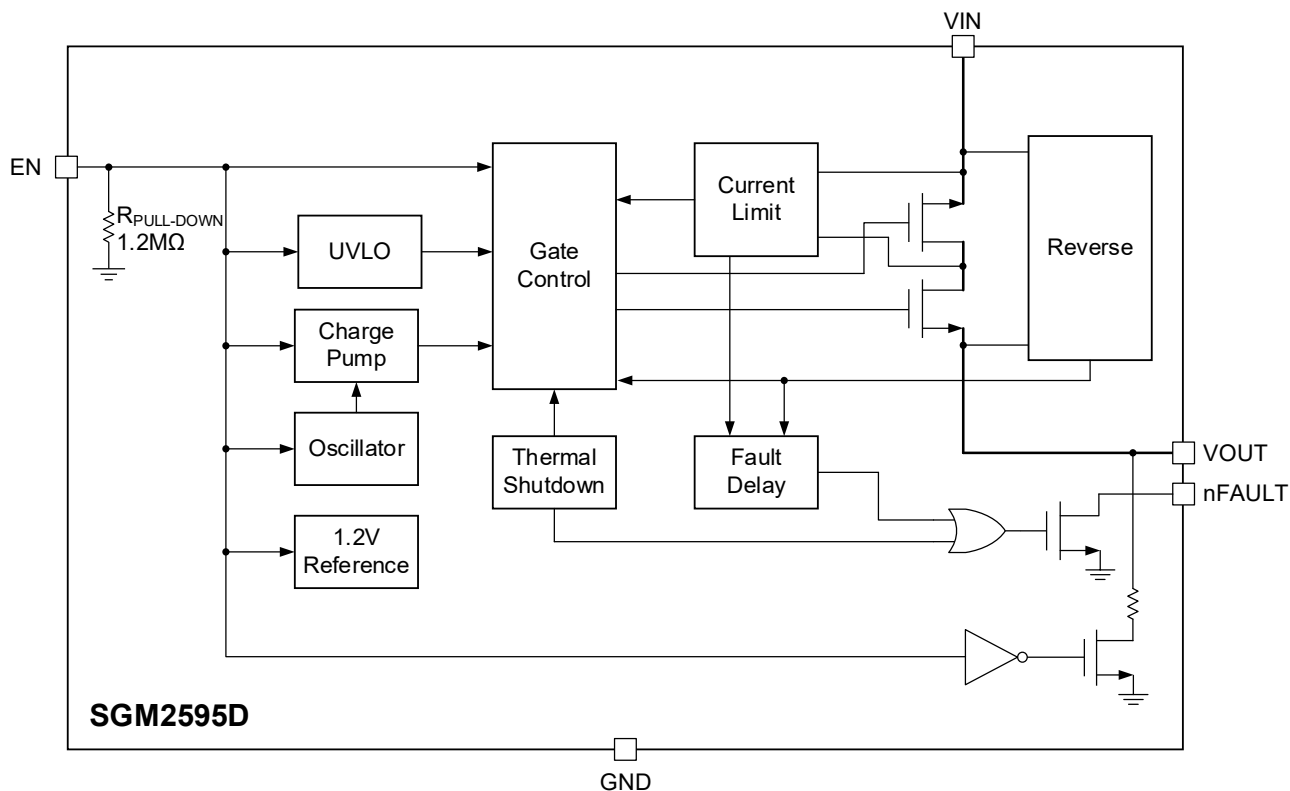

Figure 2. Block Diagram

TIMING DIAGRAM

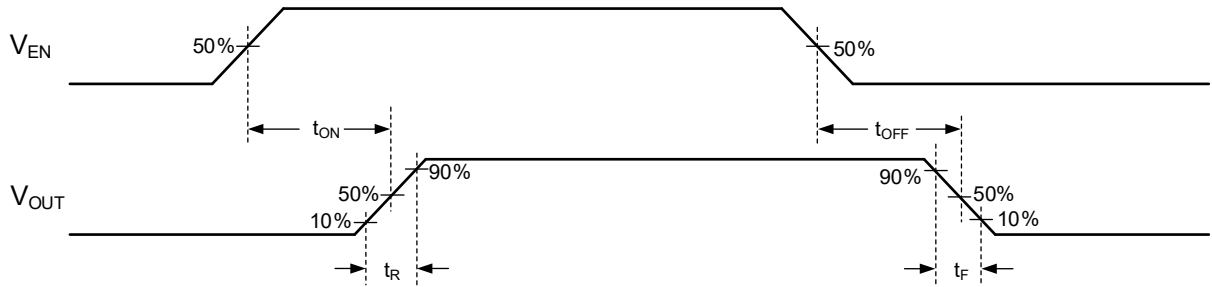

Figure 3. Switch Turn-On Time and Turn-Off Times

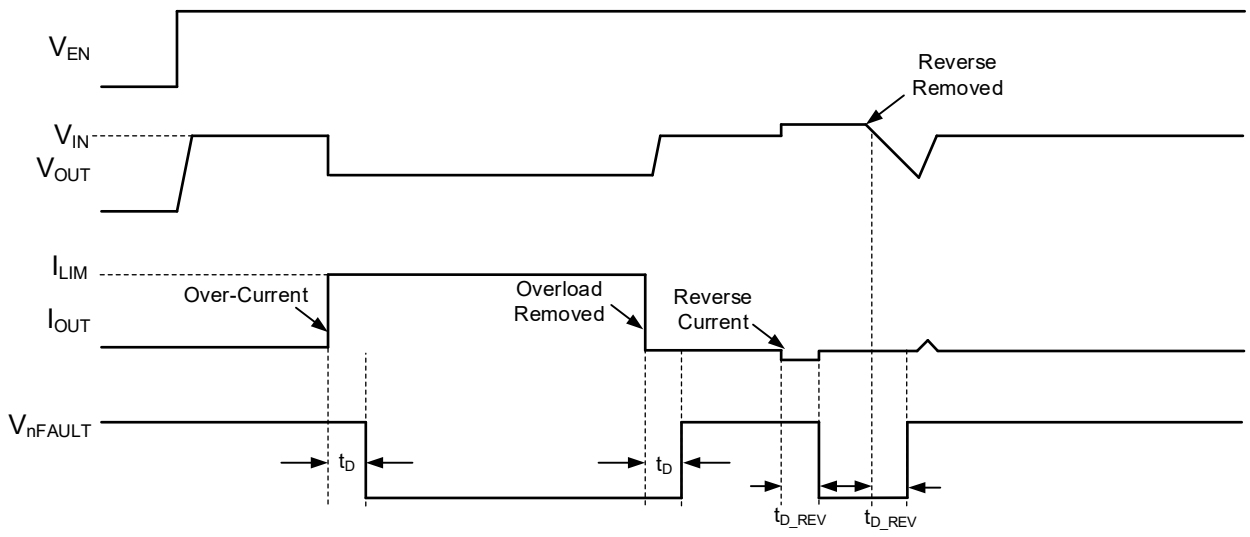

Figure 4. SGM2595D Fault Timing: Output Reset by Toggling EN

DETAILED DESCRIPTION

Input and Output

VIN should be connected to the power source that is the power supply of the internal logic circuitry and loads. Normally, load current flows from VIN to VOUT. The output MOSFET and driver circuit are designed to allow the voltage of VOUT is higher than VIN, when the device is turned off.

Thermal Shutdown (TSD)

If there's no over-current condition, the thermal shutdown threshold is +156°C with 55°C hysteresis.

Soft-Start

The soft-start feature is used to limit inrush current during startup or hot-plug events so that the device can cope with inrush current when connected to large capacitive loads.

Under-Voltage Lockout (UVLO)

If the voltage on VIN pin falls below its under-voltage lockout threshold, the device will be disabled. The device resumes operation when the power supply goes back above UVLO threshold.

Current Limit and Short-Circuit Protection

The current limit protection circuit is designed to limit the output current to protect the upstream power supply. The typical current limit threshold is set internally to 2905mA.

The nFAULT pin will be asserted after the device enters short-circuit state for t_D (15ms).

If the short-circuit state persists, the device will cycle on and off under thermal protection as a result of power dissipation.

Reverse Voltage Protection

When the output voltage exceeds the input voltage by 24mV (TYP), the device turns off the internal N-MOSFET to avoid the reverse current from the output to input. Its hysteresis voltage is 16mV (TYP).

Fault Flag (nFAULT)

The SGM2595D is designed to achieve delayed response via the internal delay "deglitch" circuit for over-current ($t_D = 15ms$, TYP) and reverse voltage ($t_{D_REV} = 3ms$, TYP) conditions. The nFAULT pin indicates the device enters and leaves the following fault state: over-current, reverse voltage after the delay time (t_D). But nFAULT will be asserted to low level as soon as the over-temperature condition occurs.

The nFAULT is the structure of N-MOSFET open-drain that outputs low level when an over-current, over-temperature or reverse voltage condition occurs. Figure 4 depicts the typical timing.

When an over-current occurs, nFAULT will not be asserted until the over-current persists for a delay time (t_D). This ensures that nFAULT will not be asserted due to disturbances such as current jitter, thus avoids false fault reports.

Output Discharge

The SGM2595D integrates the output discharge feature. When the EN pin is pulled low (below V_{IL}), a discharge resistance with a typical value of 47Ω is connected between the VOUT and GND. This resistance pulls down the output and prevents it from floating when the device is disabled.

APPLICATION INFORMATION

Power Dissipation

Assuming a given ambient temperature and an output current, the maximum allowable power dissipation is calculated by:

$$P_{D(MAX)} = \frac{T_{J(MAX)} - T_A}{\theta_{JA}} \quad (1)$$

where:

- ◆ $P_{D(MAX)}$ is the maximum power dissipation.
- ◆ $T_{J(MAX)}$ is the maximum operating junction temperature.
- ◆ T_A is the operating ambient temperature.
- ◆ θ_{JA} is junction to air thermal impedance.

Please note that the thermal vias are placed under the exposed pad of the device, thus allowing for thermal dissipation away from the device.

Supply Filter Capacitor

It is recommended to use a 10µF capacitor between VIN and GND close to the device pins. It can limit the voltage drop of the input supply. Larger C_{IN} can reduce voltage dip in high current applications. Without an input capacitor, short-circuit at the output will cause the input voltage to ring, which may destroy the chip's internal circuitry when the input transient voltage exceeds the absolute maximum supply voltage (6.5V).

Output Filter Capacitor

To reduce EMI, improve the transient performance, and minimize negative effects of resistance and inductance

between the bypass capacitor and the downstream connector, a low-ESR 10µF ceramic capacitor between VOUT and GND standard bypass methods are recommended. If the output port is connected to the load through a long cable, the parasitic inductance of the cable may cause voltage to ring, whose negative ringing may damage the chip, so an anti-parallel Schottky diode such as BAT54 is recommended to connect in parallel with the output.

PCB Layout Guidelines

A reasonable PCB layout is critical to the stable performance of the SGM2595D. For best results, follow the guidelines below.

- ◆ Keep the power traces as short and wide as possible, and use at least 2 ounces of copper.
- ◆ Placing a ground plane under all circuits to reduce resistance and inductance will improve DC and transient performances.
- ◆ Ensure that the input decoupling capacitors on VIN have a minimal trace length to VIN and GND.
- ◆ Place the output capacitors as close to the SGM2595D as possible to minimize the effect of PCB parasitic inductance.

REVISION HISTORY

NOTE: Page numbers for previous revisions may differ from page numbers in the current version.

Changes from Original (MAY 2024) to REV.A	Page
Changed from product preview to production data.....	All

PACKAGE OUTLINE DIMENSIONS

MSOP-8

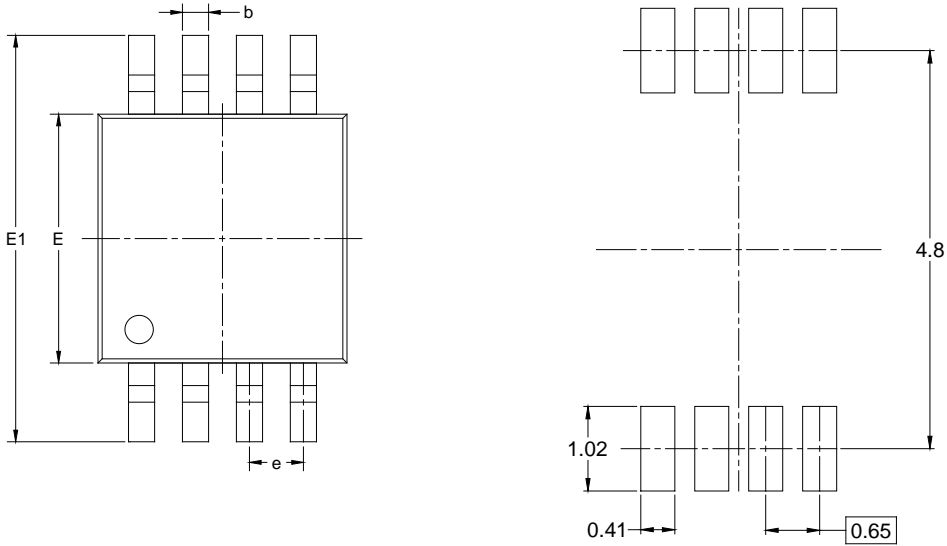

RECOMMENDED LAND PATTERN (Unit: mm)

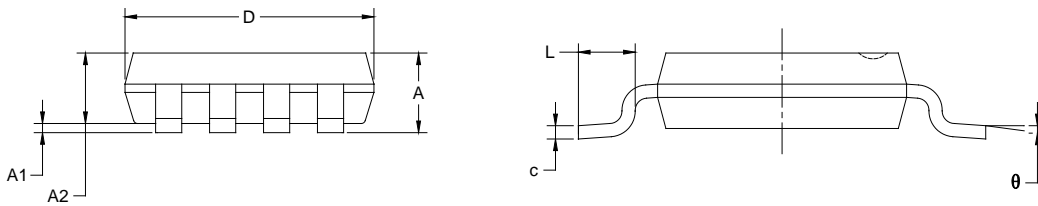

Symbol	Dimensions In Millimeters		Dimensions In Inches	
	MIN	MAX	MIN	MAX
A	0.820	1.100	0.032	0.043
A1	0.020	0.150	0.001	0.006
A2	0.750	0.950	0.030	0.037
b	0.250	0.380	0.010	0.015
c	0.090	0.230	0.004	0.009
D	2.900	3.100	0.114	0.122
E	2.900	3.100	0.114	0.122
E1	4.750	5.050	0.187	0.199
e	0.650 BSC		0.026 BSC	
L	0.400	0.800	0.016	0.031
θ	0°	6°	0°	6°

NOTES:

1. Body dimensions do not include mode flash or protrusion.
2. This drawing is subject to change without notice.

PACKAGE OUTLINE DIMENSIONS

SOT-23-5

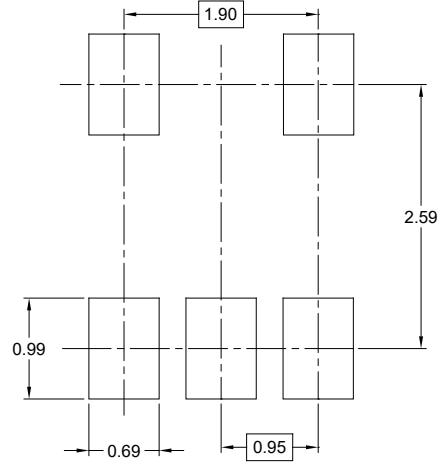
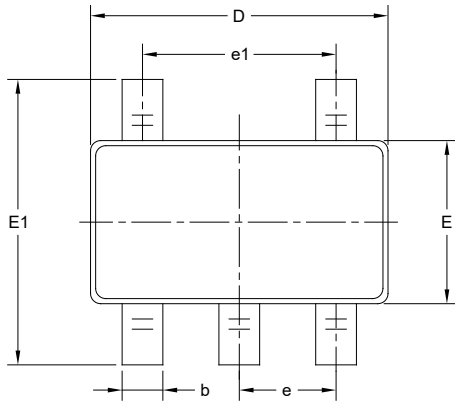

RECOMMENDED LAND PATTERN (Unit: mm)

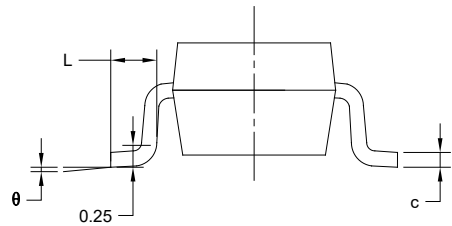
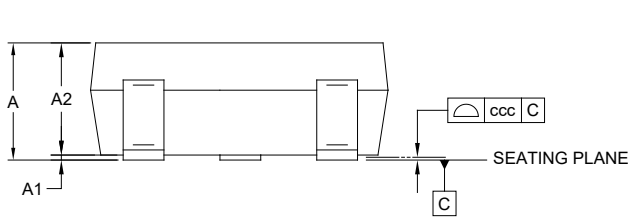

Symbol	Dimensions In Millimeters		
	MIN	MOD	MAX
A	-	-	1.450
A1	0.000	-	0.150
A2	0.900	-	1.300
b	0.300	-	0.500
c	0.080	-	0.220
D	2.750	-	3.050
E	1.450	-	1.750
E1	2.600	-	3.000
e	0.950 BSC		
e1	1.900 BSC		
L	0.300	-	0.600
θ	0°	-	8°
ccc	0.100		

NOTES:

1. This drawing is subject to change without notice.
2. The dimensions do not include mold flashes, protrusions or gate burrs.
3. Reference JEDEC MO-178.

TAPE AND REEL INFORMATION

REEL DIMENSIONS



TAPE DIMENSIONS



NOTE: The picture is only for reference. Please make the object as the standard.

KEY PARAMETER LIST OF TAPE AND REEL

Package Type	Reel Diameter	Reel Width W1 (mm)	A0 (mm)	B0 (mm)	K0 (mm)	P0 (mm)	P1 (mm)	P2 (mm)	W (mm)	Pin1 Quadrant
MSOP-8	13"	12.4	5.20	3.30	1.50	4.0	8.0	2.0	12.0	Q1
SOT-23-5	7"	9.5	3.20	3.20	1.40	4.0	4.0	2.0	8.0	Q3

DD0001

PACKAGE INFORMATION

CARTON BOX DIMENSIONS



NOTE: The picture is only for reference. Please make the object as the standard.

KEY PARAMETER LIST OF CARTON BOX

Reel Type	Length (mm)	Width (mm)	Height (mm)	Pizza/Carton
7" (Option)	368	227	224	8
7"	442	410	224	18
13"	386	280	370	5

DD0002