

GENERAL DESCRIPTION

The SGM66099B is an ultra-low quiescent current synchronous Boost converter. 1.15V to 5.2V operation input voltage is suitable for Li-Mn battery, NiMH and Li-Ion rechargeable batteries. The 1.7 μ A (TYP) quiescent current maximizes the light load efficiency and also increases the effective battery operation time. In addition, the high-side synchronous rectifier provides output disconnect feature which minimizes unnecessary current drawn from the battery during shutdown mode.

The SGM66099B is able to deliver 300mA output current from 3.3V to 5V conversion, and achieves up to 93% efficiency at 200mA load.

The device provides down mode where the desired output voltage is regulated even when input voltage is higher than the output. In addition, when the input voltage is 300mV above the output voltage set point, the device enters pass-through mode.

The device integrates various protection features such as over-current protection, over-voltage protection and thermal shutdown. In addition, the synchronous rectifier supports short circuit protection which further improves the robustness of the device.

The SGM66099B provides both adjustable output voltage and fixed output voltage versions. It is available in Green WLCSP-1.22 \times 0.83-6B and TDFN-2 \times 2-6AL packages.

FEATURES

- **Operating Input Voltage Range: 1.15V to 5.2V**
- **Ultra-Low Quiescent Current**
 - ◆ 1.7 μ A (TYP) Ultra-Low I_Q into VOUT Pin
 - ◆ 0.05 μ A (TYP) Ultra-Low I_Q into VIN Pin
- **1.2MHz Fixed Frequency Operation**
- **Adjustable Output Voltage from 2.5V to 5.2V**
- **5.0V Fixed Output Voltage Version**
- **Power-Save Mode for Improved Efficiency at Low Output Power**
- **Regulated Output Voltage in Down Mode**
- **True Disconnection During Shutdown**
- **Up to 93% Efficiency from 10mA to 300mA Load**
- **-40°C to +85°C Operating Temperature Range**
- **Available in Green WLCSP-1.22 \times 0.83-6B and TDFN-2 \times 2-6AL Packages**

APPLICATIONS

- LCD Bias
- Optical Heart Rate Monitor LED Bias
- Portable and Wearable Applications
- Low Power Wireless Applications
- Battery Powered Systems

TYPICAL APPLICATION

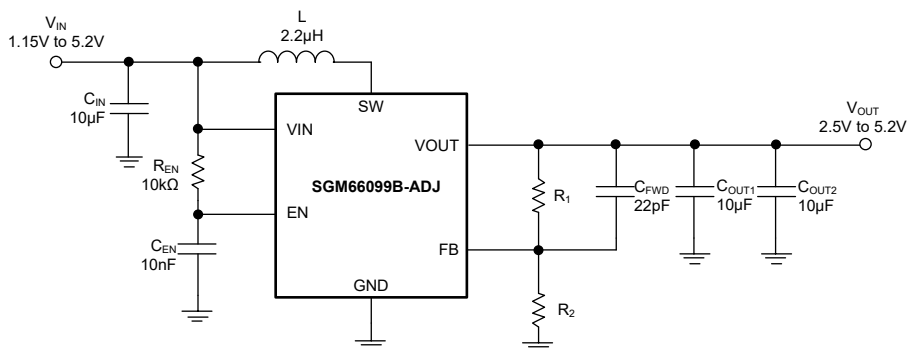
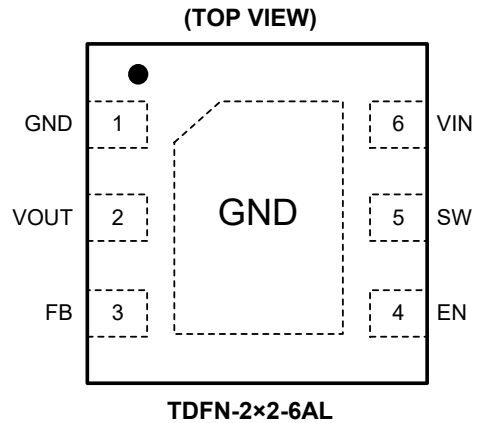
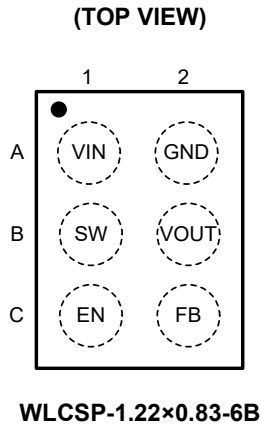

Figure 1. Typical Application Circuit

PIN CONFIGURATIONS



PIN DESCRIPTION

| PIN | | NAME | TYPE | FUNCTION |
|--------------------|--------------|------|------|---|
| WLCSP-1.22×0.83-6B | TDFN-2×2-6AL | | | |
| A1 | 6 | VIN | P | Power Supply Input. |
| A2 | 1 | GND | G | Ground. |
| B1 | 5 | SW | O | Switch Node. Drain connection of low-side power MOSFET. |
| B2 | 2 | VOUT | O | Boost Converter Output. |
| C1 | 4 | EN | I | Device Enable Node. Pulling this pin logic high enables the device, logic low disables the device. |
| C2 | 3 | FB | I | Voltage Feedback of Adjustable Output Voltage. Connect a resistive divider to program the desired output voltage. Connect to the GND pin for fixed output voltage version and do not leave FB pin floating. |
| — | Exposed Pad | GND | — | Connect to GND. |

NOTE: I: input, O: output, G: ground, P: power for the circuit.

ELECTRICAL CHARACTERISTICS

($V_{IN} = 1.15V$ to $5.2V$, $C_{IN} = 10\mu F$, $C_{OUT} = 20\mu F$. Full = $-40^{\circ}C$ to $+85^{\circ}C$, typical values are at $V_{IN} = 3.7V$, $T_A = +25^{\circ}C$, unless otherwise noted.)

| PARAMETER | SYMBOL | CONDITIONS | TEMP | MIN | TYP | MAX | UNITS |
|--|------------------|--|-------|---------------------|-------|----------------------|------------|
| Power Supply | | | | | | | |
| Input Voltage Range | V_{IN} | | +25°C | 1.15 | | 5.2 | V |
| Quiescent Current into VIN Pin | I_Q | No load, not switching | Full | | 0.05 | 0.30 | μA |
| Quiescent Current into VOUT Pin | | No load, not switching, Boost or down mode (SGM66099B-ADJ) | Full | | 1.7 | 7.0 | μA |
| | | No load, not switching, Boost or down mode (SGM66099B-5.0) | Full | | 12 | 22 | μA |
| Shutdown Current into VIN Pin | I_{SD} | EN = GND, $V_{IN} = 3.6V$ | Full | | 0.1 | 1.0 | μA |
| Output | | | | | | | |
| Output Voltage Range | V_{OUT} | | Full | 2.5 | | 5.2 | V |
| Output Voltage | | SGM66099B-5.0, $V_{IN} < V_{OUT}$, PWM mode | Full | 4.84 | 5.00 | 5.10 | V |
| | | SGM66099B-5.0, $V_{IN} < V_{OUT}$, PFM mode | +25°C | | 5.02 | | V |
| Feedback Reference Voltage | V_{REF} | $V_{IN} < V_{OUT}$, PWM mode | Full | 0.965 | 1.000 | 1.038 | V |
| | | $V_{IN} < V_{OUT}$, PFM mode | +25°C | | 1.010 | | V |
| Output Over-Voltage Protection Threshold | V_{OVP} | V_{OUT} rising (WLCSP) | +25°C | 5.30 | 5.70 | 5.87 | V |
| | | V_{OUT} rising (TDFN) | +25°C | 5.23 | 5.70 | 5.99 | |
| OVP Hysteresis | | | +25°C | | 100 | | mV |
| Leakage Current into FB Pin | I_{FB_LKG} | $V_{FB} = 1.1V$ | Full | | 10 | 50 | nA |
| Switching | | | | | | | |
| Switching Frequency | f_{SW} | $V_{IN} = 3.7V$ | Full | 0.9 | 1.2 | 1.55 | MHz |
| Power Switch | | | | | | | |
| Low-side Switch On-Resistance | $R_{DS(ON)_LS}$ | $V_{OUT} = 4.7V$ (TDFN) | +25°C | | 280 | 400 | m Ω |
| | | $V_{OUT} = 4.7V$ (WLCSP) | +25°C | | 230 | 330 | m Ω |
| | | $V_{OUT} = 3.3V$ (TDFN) | +25°C | | 340 | 480 | m Ω |
| | | $V_{OUT} = 3.3V$ (WLCSP) | +25°C | | 290 | 400 | m Ω |
| Rectifier On-Resistance | $R_{DS(ON)_HS}$ | $V_{OUT} = 4.7V$ (TDFN) | +25°C | | 270 | 380 | m Ω |
| | | $V_{OUT} = 4.7V$ (WLCSP) | +25°C | | 250 | 360 | m Ω |
| | | $V_{OUT} = 3.3V$ (TDFN) | +25°C | | 350 | 490 | m Ω |
| | | $V_{OUT} = 3.3V$ (WLCSP) | +25°C | | 330 | 470 | m Ω |
| Current Limit Threshold | I_{LIM} | | +25°C | 0.90 | 1.30 | 1.64 | A |
| Control Logic | | | | | | | |
| EN Input Low Voltage Threshold | V_{IL} | $V_{IN} \leq 1.5V$ | Full | | | $0.14 \times V_{IN}$ | V |
| | | $V_{IN} > 1.5V$ | Full | | | 0.3 | V |
| EN Input High Voltage Threshold | V_{IH} | $V_{IN} \leq 1.5V$ | Full | $0.8 \times V_{IN}$ | | | V |
| | | $V_{IN} > 1.5V$ | Full | 1.2 | | | V |
| Leakage Current into EN Pin | I_{EN_LKG} | $V_{EN} = 5.0V$ | +25°C | | | 300 | nA |
| Thermal Shutdown Threshold | | | | | 150 | | °C |
| Thermal Shutdown Hysteresis | | | | | 25 | | °C |

TYPICAL PERFORMANCE CHARACTERISTICS

$C_{IN} = 10\mu F$ and $C_{OUT} = 20\mu F$, unless otherwise noted.

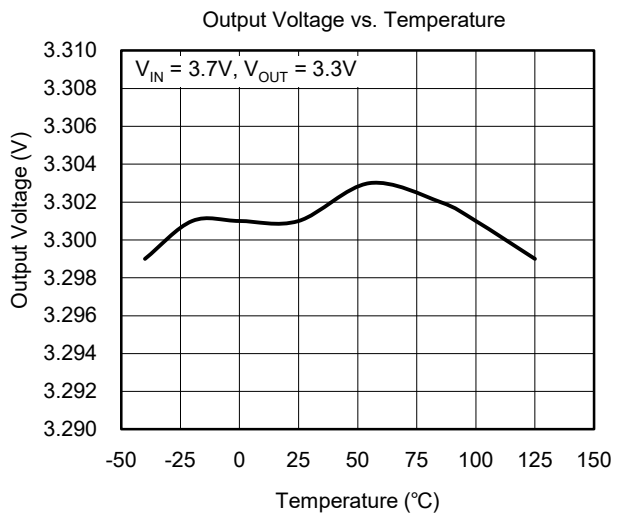
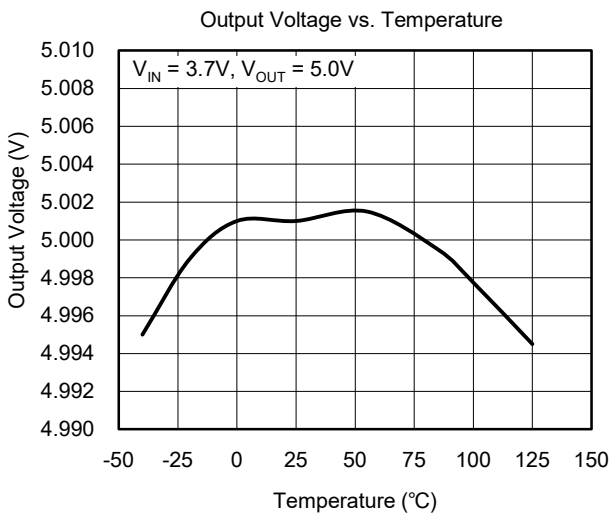
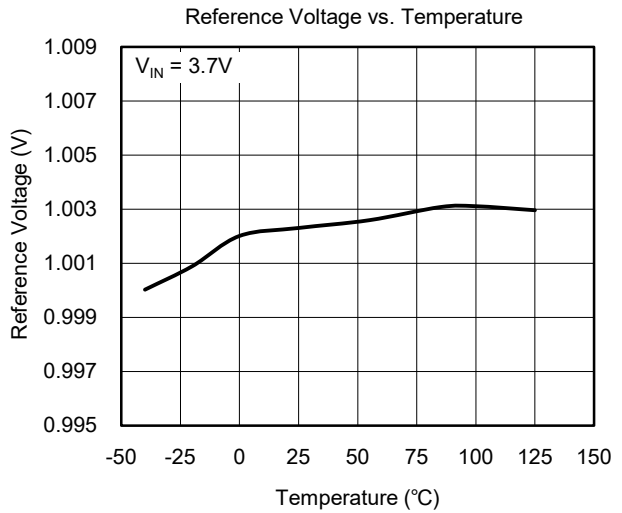
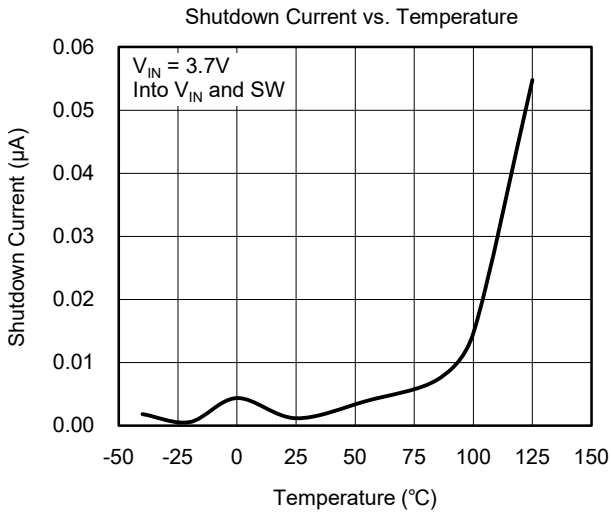
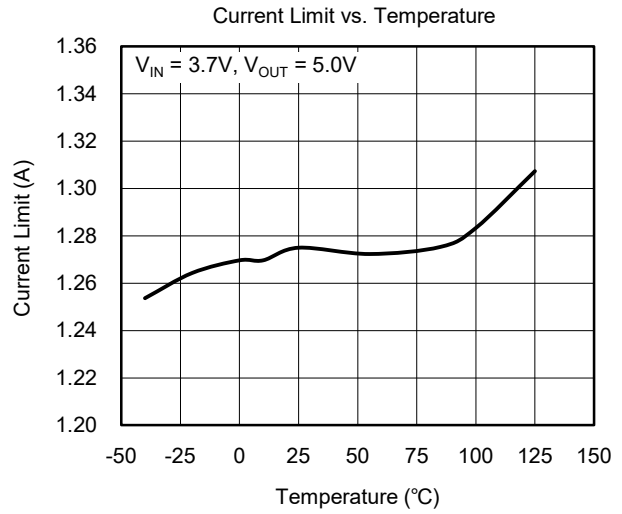
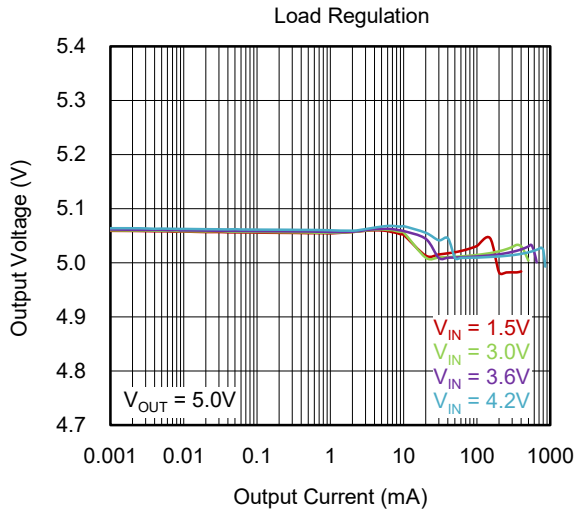

TYPICAL PERFORMANCE CHARACTERISTICS (continued)

$C_{IN} = 10\mu F$ and $C_{OUT} = 20\mu F$, unless otherwise noted.

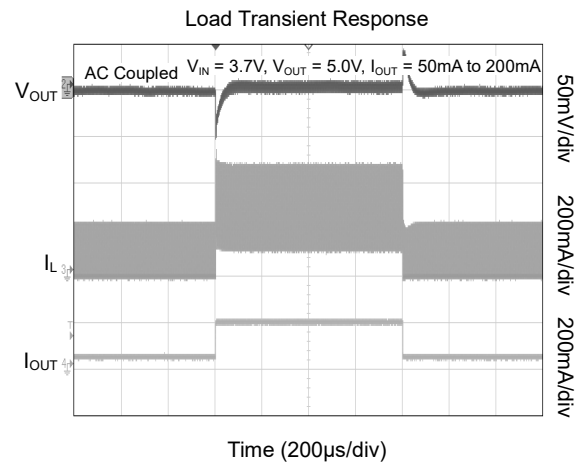
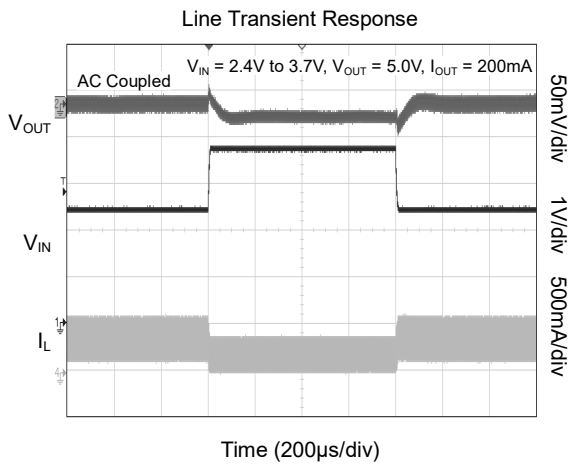
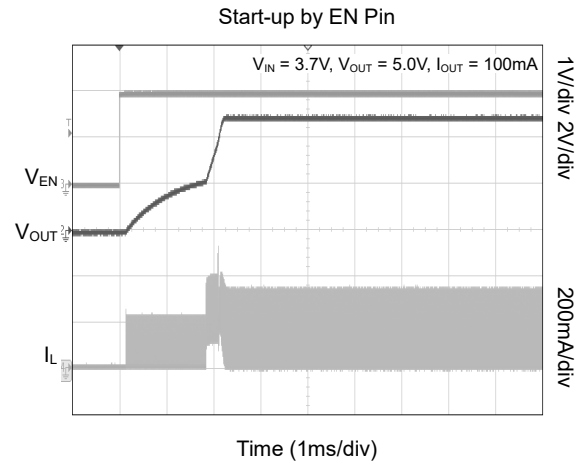
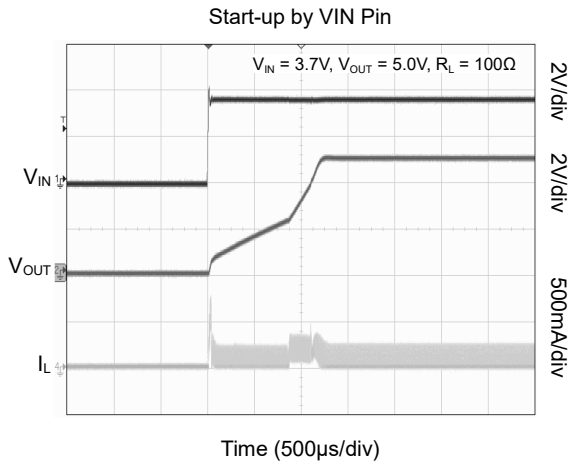
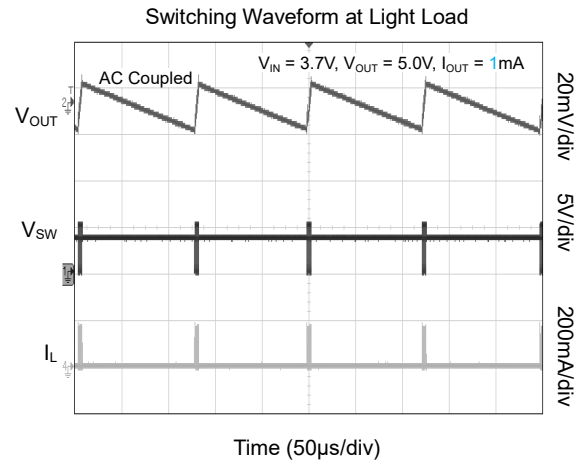
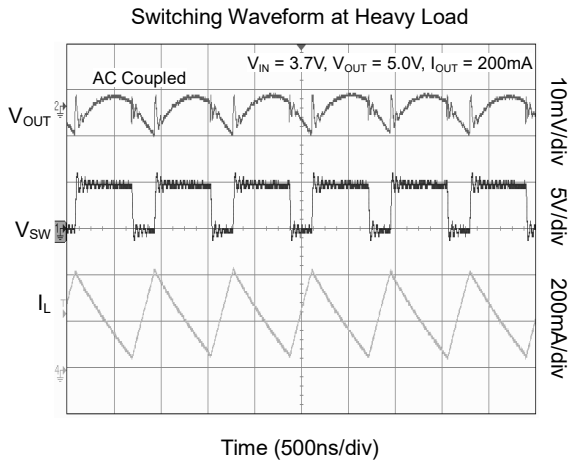

TYPICAL PERFORMANCE CHARACTERISTICS (continued)

$C_{IN} = 10\mu F$ and $C_{OUT} = 20\mu F$, unless otherwise noted.

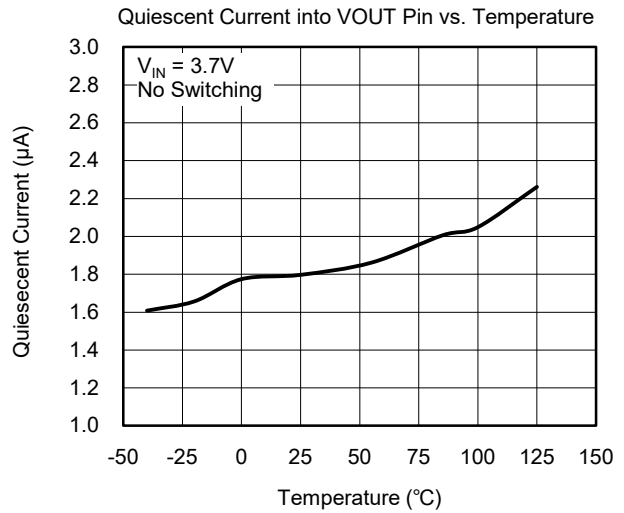
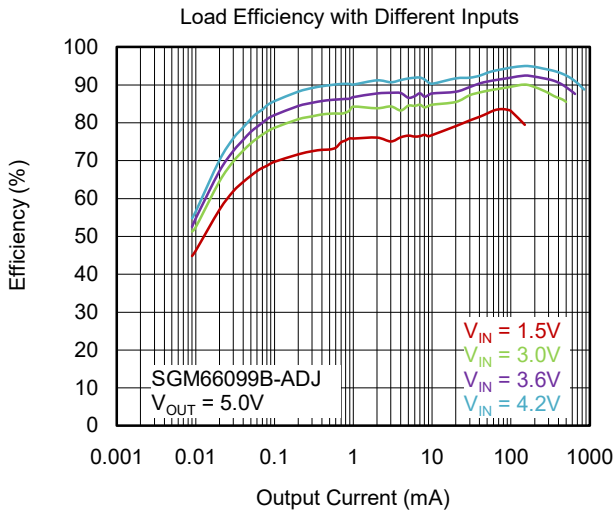
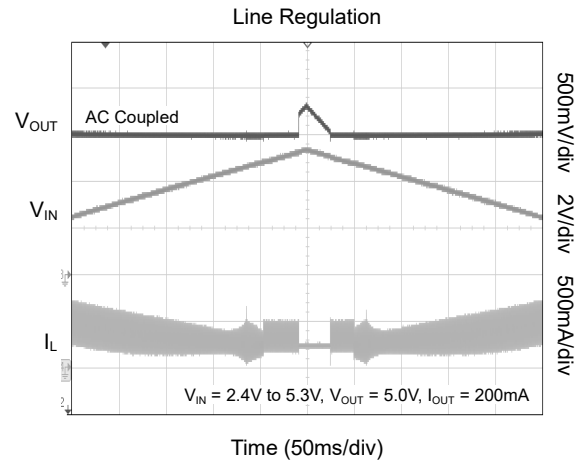
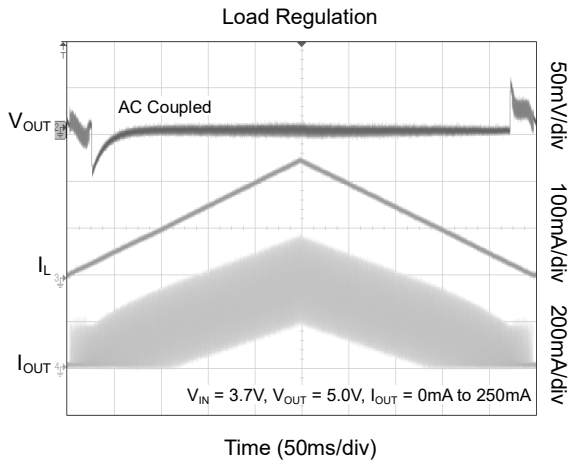

FUNCTIONAL BLOCK DIAGRAM

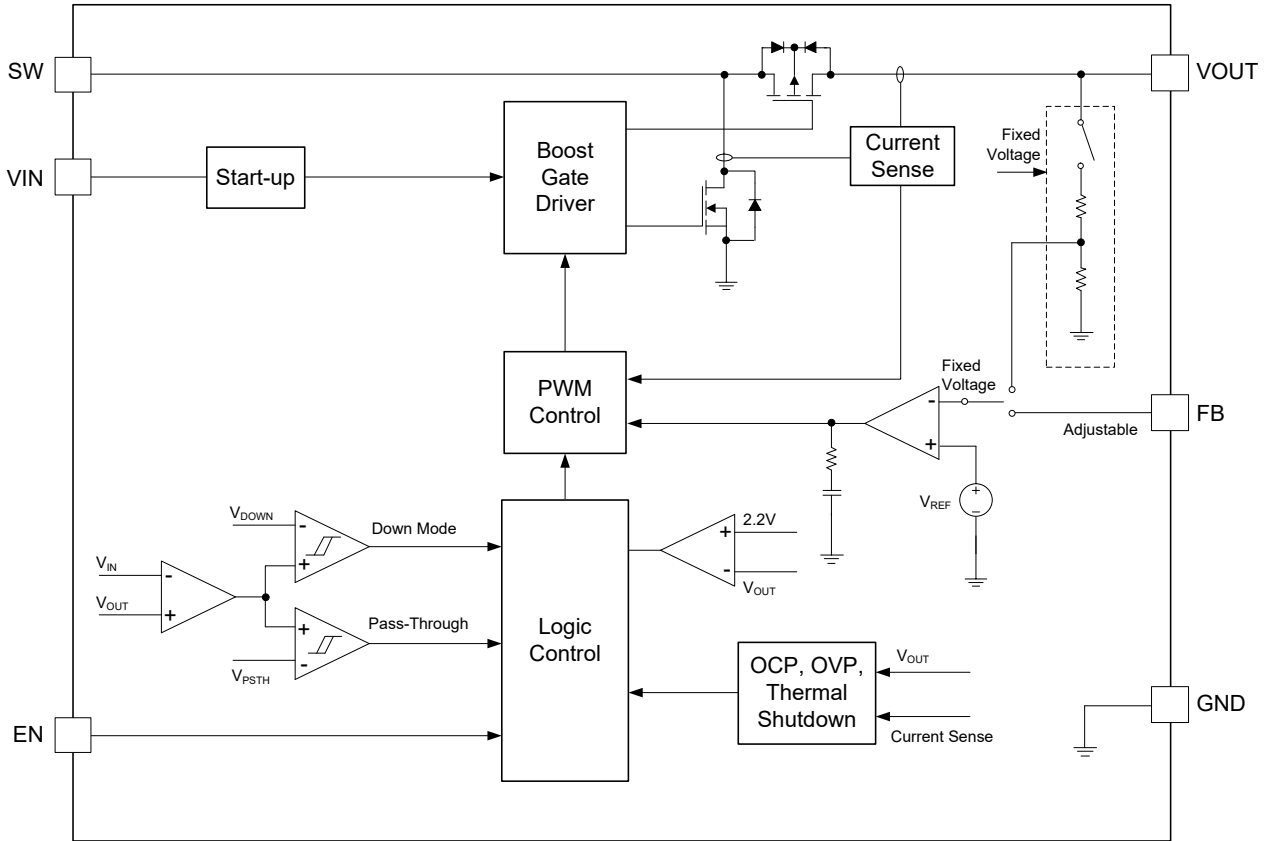

Figure 2. Block Diagram

DETAILED DESCRIPTION

The SGM66099B synchronous Boost converter is designed for Li-Ion battery powered systems, where the compact solution size and battery operation time are key criterions. The device can operate with a wide input voltage from 1.15V to 5.2V. The 1.7 μ A (TYP) quiescent current and light load power-save mode further improve the system efficiency. The device employs peak current mode control with 1.3A (TYP) peak switch current limit. The SGM66099B is capable of disconnecting the output from input when the device is disabled to avoid unnecessary current consumption. The integrated down mode and pass-through mode ensure a smooth operation when input voltage is close to or higher than the set output voltage. The device can operate both in the adjustable output voltage version and fixed output voltage version.

Start-up and Enable

Logic high on EN pin enables the SGM66099B, while a logic low disables the device. During logic low state, the device stops operation, and the output voltage is completely disconnected from the input voltage. During logic low state, the shutdown current is less than 1 μ A.

The SGM66099B is able to start up from 1.15V input voltage with larger than 3k Ω load. Before the output voltage reaches 2.2V during the start-up phase, the switch current is limited to about 200mA. Therefore, if the load during start-up is too heavy, the device will fail to charge the output voltage to above 2.2V after soft-start time expires, and it will not be able to start up successfully.

Over-Current and Short Circuit Protection

The SGM66099B implements cycle-by-cycle current limit during an over-current event. When the current limit threshold (I_{LIM}) is reached, the low-side power MOSFET is turned off to prevent the inductor current from further increase. During over-current event, the output voltage will drop until a constant power state is reached between input and output. If the current limit causes the output to drop below the input voltage, the SGM66099B enters down mode, where the peak current is still limited by I_{LIM} cycle-by-cycle. If the output continues dropping below 2.2V, the device enters start-up process again.

The SGM66099B may not be shut down by pulling the EN to logic low when the supply voltage is below 0.85V,

while the supply voltage can drop to as low as 0.3V for maintain the output voltage with light loadings.

During the output short-to-ground case, as output voltage declines below 2.2V, the SGM66099B reduces the current limit to about 200mA to reduce power dissipation within the device. As the short circuit condition is removed, the device resumes operation and goes through a soft-start sequence to regulate the set output voltage.

Over-Voltage Protection

SGM66099B integrates over-voltage protection (OVP) to protect the device in the event of feedback resistor short-to-ground or incorrect feedback resistor value being populated. The SGM66099B stops switching when the OVP threshold of 5.7V (TYP) is reached. The device implements 100mV OVP hysteresis. When the output voltage is 100mV lower than the OVP threshold, the device resumes switching.

Power-Save Mode under Light Load Condition

The SGM66099B enters into power-save mode under light load condition.

Down Mode and Pass-Through Mode

SGM66099B offers down mode feature where the device can still regulate the set output voltage even when the input voltage is higher than output voltage. If the input voltage continues increasing in down mode, the device automatically enters pass-through mode. Care should be taken in pass-through mode, where the input voltage should not exceed the recommended maximum input voltage.

In down mode, the control logic pulls the gate of PMOS to the input voltage rather than ground. This method allows effective control of inductor current when $V_{IN} > V_{OUT}$. Thermal consideration should be taken in down mode, where the voltage drop on the PMOS increases as the delta of V_{IN} and V_{OUT} increases.

In pass-through mode, the complimentary switching action stops. The gate of PMOS is pulled to ground for always-on and the low-side switch remains off. The output voltage is equal to the input voltage minus the voltage drop across the DC resistance (DCR) of the inductor and the on-resistance of the rectified PMOS.

DETAILED DESCRIPTION (continued)

SGM66099B enters down mode when the input voltage is equal to or higher than $V_{OUT} - 100\text{mV}$. It remains in down mode until the V_{IN} is more than $V_{OUT} + 0.3\text{V}$ and then automatically enters pass-through mode. In pass-through mode, the high-side PMOS is always turned on to pass the input voltage to the output. As V_{IN} drops below 1% above the target output voltage, the device exits pass-through mode and returns to down mode. The device exits down mode and returns to normal Boost switching operation as V_{IN} drops 150mV below the target output voltage.

Thermal Shutdown

A thermal shutdown function is implemented to prevent damage caused by excessive heat and power dissipation. Once a junction temperature of $+150^{\circ}\text{C}$ (TYP) is exceeded, the device is shut down. The device is released from shutdown automatically when the junction temperature decreases by 25°C .

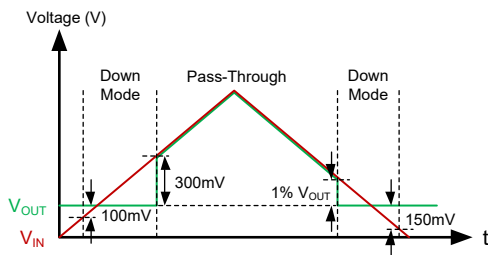

Figure 3. Down Mode and Pass-Through Mode

APPLICATION INFORMATION

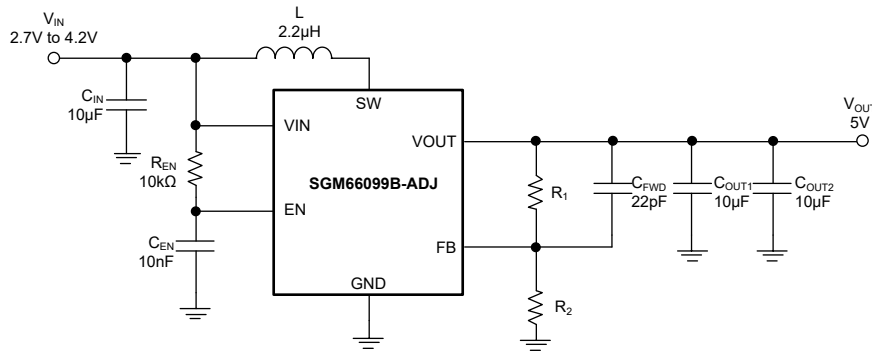

Figure 4. 5V Output Boost Converter

Design Requirements

5V output at 1mA load current is used to provide system bias power or LED bias voltage from a single cell Li-Ion battery as an example. The selection of external component values for the SGM66099B-ADJ can reference the following design procedure.

Table 1. Design Requirements

| PARAMETERS | VALUES |
|-----------------------|-------------|
| Input Voltage | 2.7V ~ 4.2V |
| Output Voltage | 5V |
| Output Current | 1mA |
| Output Voltage Ripple | ±50mV |

Programming the Output Voltage

External resistor dividers R_1 and R_2 (see Figure 4) can be used to set the output voltage. The typical voltage at the FB pin is V_{REF} of 1.0V.

$$V_{OUT} = V_{REF} \times \frac{R_1 + R_2}{R_2} \quad (1)$$

The leakage current into the FB pin affects the accuracy of output voltage. To minimize the leakage current effect, the current flowing through R_2 should be 100 times greater than FB pin leakage current. Small R_2 increases the noise immunity, while large R_2 reduces the leakage current flowing through feedback resistors, which improves the no load efficiency of the device. 1MΩ and 249kΩ resistors are selected for R_1 and R_2 respectively in this case. ±1% accuracy resistors are recommended for R_1 and R_2 to improve output voltage accuracy.

An external feed-forward capacitor (C_{FWD}) from 10pF to 22pF in parallel with R_1 is recommended to improve device's stability.

For fixed output voltage version, connect the FB pin to GND and do not leave FB pin floating.

Maximum Output Current

The maximum output load capability of SGM66099B depends on the minimum desired operation input voltage and the current limit of the device. The maximum load current can be estimated by Equation 2,

$$I_{OUT(MAX)} = \frac{V_{IN} \cdot (I_{LIM} - \frac{I_{LH}}{2}) \cdot \eta}{V_{OUT}} \quad (2)$$

where η is the conversion efficiency, using 85% for estimation, I_{LH} is the inductor peak-to-peak ripple current and I_{LIM} is the switch current limit.

For worst-case condition analysis, the minimum input voltage, maximum Boost output voltage and minimum current limit (I_{LIM}) should be used.

Inductor Selection

Inductor selection is one of the most important criteria for switch mode power supply, because the inductor selection may affect the power supply's transient response, loop stability, efficiency and steady-state operation. Inductor parameters of DC resistance (DCR), inductance and saturation current are critical for a smooth and efficient power supply operation.

The internal compensation of the device is optimized with 1µH and 2.2µH. When V_{OUT} is higher than 3V, 2.2µH inductance should be selected. When V_{OUT} is less than 3V, 1.1µH inductance should be selected.

APPLICATION INFORMATION (continued)

Table 2. List of Inductors

| V _{OUT} (V) | Inductance (μH) | Saturation Current (A) | DC Resistance (mΩ) | Size L × W × H (mm ³) | Part Number | Manufacturer |
|----------------------|-----------------|------------------------|--------------------|-----------------------------------|------------------|------------------|
| > 3.0 | 2.2 | 1.95 | 80 | 2.5 × 2.0 × 1.2 | 74404024022 | Würth Elektronik |
| | 2.2 | 1.7 | 92 | 2.5 × 2.0 × 1.1 | LQH2HPN2R2MJR | muRata |
| | 2.2 | 1.45 | 163 | 2.0 × 1.6 × 1.0 | VLS201610CX-2R2M | TDK |
| ≤ 3.0 | 1.0 | 2.6 | 37 | 2.5 × 2.0 × 1.2 | 74404024010 | Würth Elektronik |
| | 1.0 | 2.3 | 48 | 2.5 × 2.0 × 1.0 | MLP2520W1R0MT0S1 | TDK |
| | 1.0 | 1.5 | 80 | 2.0 × 1.2 × 1.0 | LQM21PN1R0MGH | muRata |

Capacitor Selection

The input capacitor of Boost converter not only minimizes input voltage ripple, but also reduces any voltage spike presenting on IC's VIN pin. A 10μF, low ESR and X5R or higher temperature coefficient ceramic capacitor is recommended to place as close to the VIN and GND pins as possible to improve transient response and EMI behavior.

Boost converter's output capacitor plays a significant role in ensuring good system performance. The location of output capacitor will have an effect on the switching spikes on the SW pin, which ultimately affects EMI performance and potentially damages the IC due to large switching spikes. The current loop formed by the output capacitor flowing from the VOUT pin and back to the GND pin should be as small as possible. Therefore, a ceramic cap should be placed as close to the VOUT and GND pins of the IC as possible.

Boost topology presents right-half-plane-zero which is dictated by inductance. In addition, the output capacitor sets the corner frequency of the converter for current mode controlled method. Therefore, for a larger inductor, a larger output capacitor must be used. The device's internal compensation is optimized to operate with inductance values between 1μH and 2.2μH, resulting in the minimum output capacitor value of 20μF (nominal value). Increasing the output capacitor can reduce output ripple in PWM mode.

Due to the nature of ceramic capacitors' DC bias effect, effective capacitance at the bias voltage should be verified. GRM188R60J106ME84D, a 10μF ceramic capacitor, is used for V_{OUT} rail. It has high effective capacitance value under DC biased condition.

In the case of load hot-plugging, the input capacitance of load device needs to be less than 1/10 of the output capacitance of SGM66099B.

Layout

In addition to component selection, layout is a critical step to ensure the performance of any switch mode power supplies. Poor layout could result in system instability, EMI failure, and device damage. Thus, place the inductor, input and output capacitors as close to the IC as possible, and use wide and short traces for current carrying traces to minimize PCB inductance.

For Boost converter, the current loop of the output capacitor from VOUT pin back to the GND pin of the device should be as small as possible.

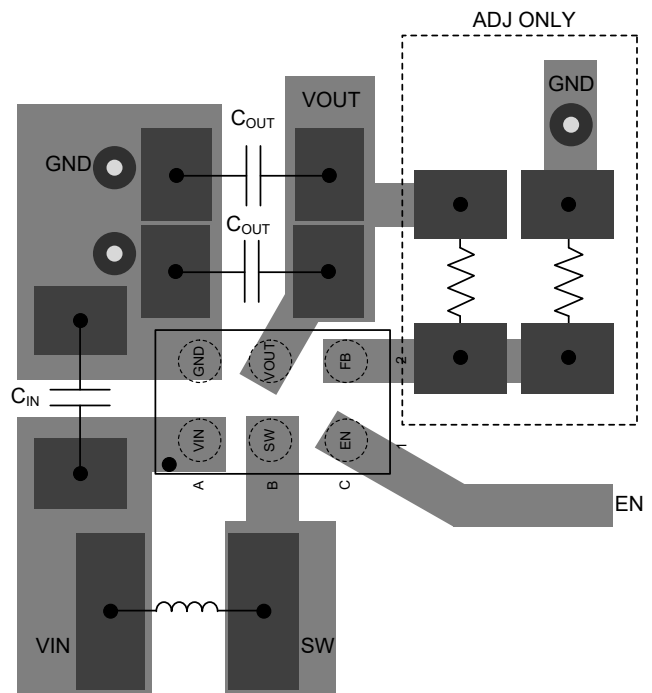

Figure 5. SGM66099B PCB Layout

REVISION HISTORY

NOTE: Page numbers for previous revisions may differ from page numbers in the current version.

| | |
|---|---------------------|
| AUGUST 2022 – REV.A.4 to REV.B | Page |
| Updated typical performances of Load Regulation and Load Efficiency with Different Inputs | 5, 7 |
| MAY 2022 – REV.A.3 to REV.A.4 | Page |
| Added PCB Layout | 12 |
| Updated Detailed Description section | 9, 10 |
| AUGUST 2021 – REV.A.2 to REV.A.3 | Page |
| Updated Figure 1 and Application Information section | 1, 11 |
| JULY 2021 – REV.A.1 to REV.A.2 | Page |
| Updated the Functional Block Diagram and product description sections | 1, 8, 9, 10, 11, 12 |
| FEBRUARY 2021 – REV.A to REV.A.1 | Page |
| Updated FB pin function | 3, 11 |
| Changes from Original (JUNE 2020) to REV.A | Page |
| Changed from product preview to production data | All |

PACKAGE OUTLINE DIMENSIONS

WLCSP-1.22x0.83-6B

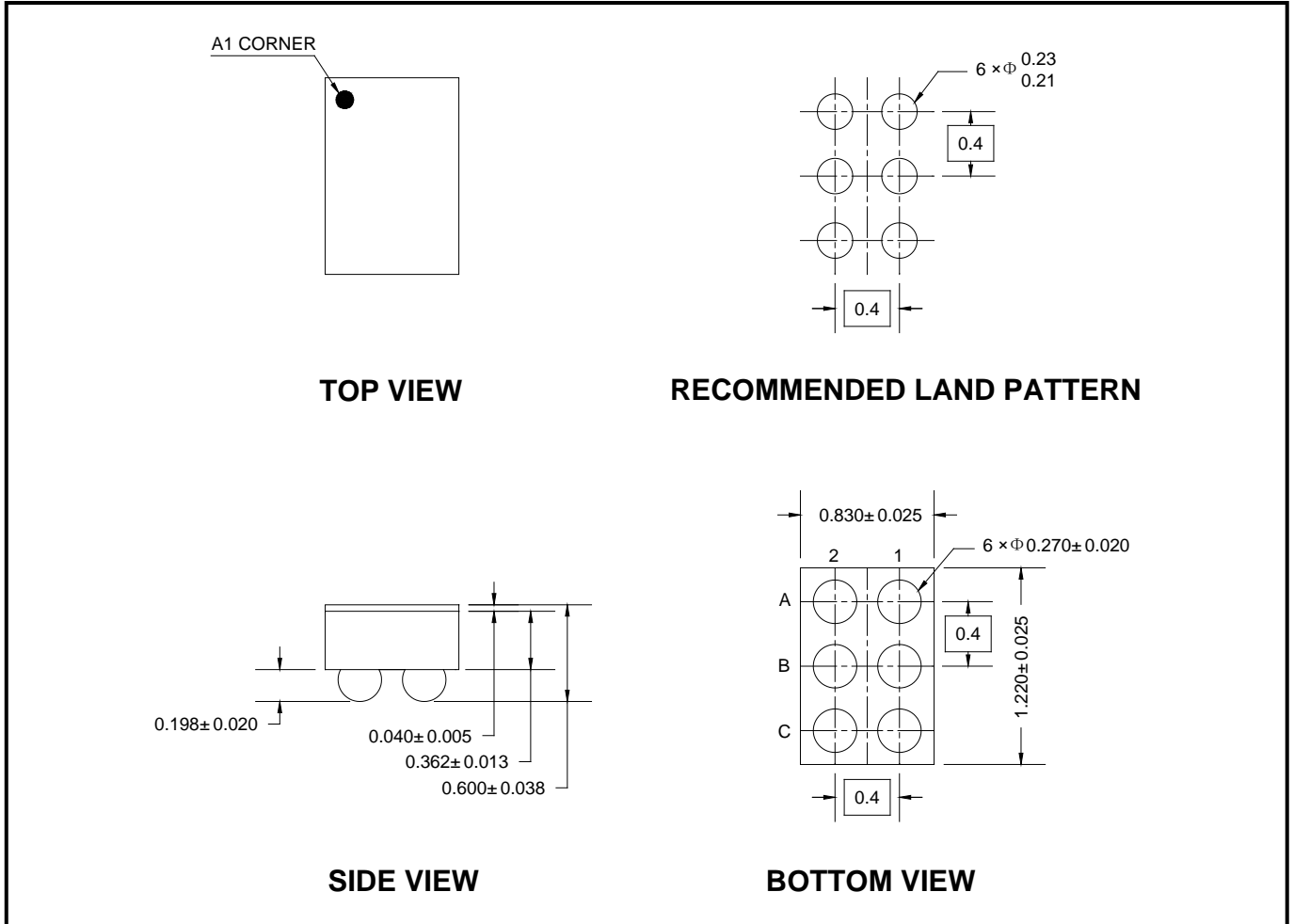

NOTES:

1. All linear dimensions are in millimeters.
2. This drawing is subject to change without notice.

PACKAGE OUTLINE DIMENSIONS

TDFN-2x2-6AL

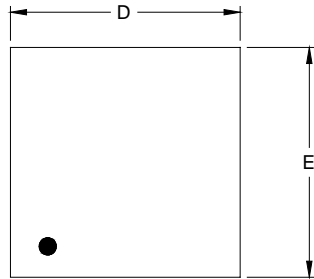

TOP VIEW

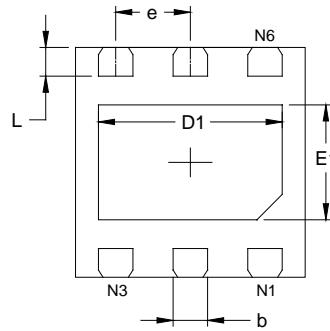

BOTTOM VIEW

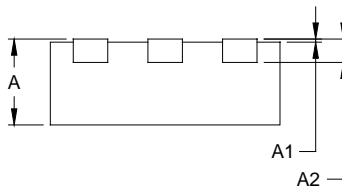

SIDE VIEW

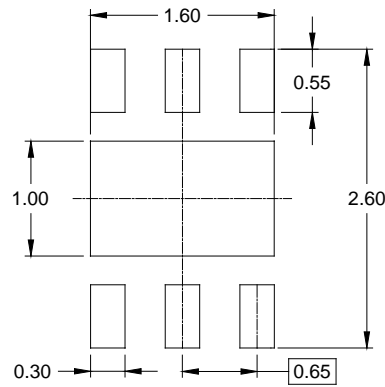

RECOMMENDED LAND PATTERN (Unit: mm)

| Symbol | Dimensions In Millimeters | | Dimensions In Inches | |
|--------|------------------------------|-------|-------------------------|-------|
| | MIN | MAX | MIN | MAX |
| A | 0.700 | 0.800 | 0.028 | 0.031 |
| A1 | 0.000 | 0.050 | 0.000 | 0.002 |
| A2 | 0.203 REF | | 0.008 REF | |
| D | 1.900 | 2.100 | 0.075 | 0.083 |
| D1 | 1.500 | 1.700 | 0.059 | 0.067 |
| E | 1.900 | 2.100 | 0.075 | 0.083 |
| E1 | 0.900 | 1.100 | 0.035 | 0.043 |
| b | 0.250 | 0.350 | 0.010 | 0.014 |
| e | 0.650 BSC | | 0.026 BSC | |
| L | 0.174 | 0.326 | 0.007 | 0.013 |

NOTE: This drawing is subject to change without notice.

TAPE AND REEL INFORMATION

REEL DIMENSIONS



TAPE DIMENSIONS



NOTE: The picture is only for reference. Please make the object as the standard.

KEY PARAMETER LIST OF TAPE AND REEL

| Package Type | Reel Diameter | Reel Width W1 (mm) | A0 (mm) | B0 (mm) | K0 (mm) | P0 (mm) | P1 (mm) | P2 (mm) | W (mm) | Pin1 Quadrant |
|--------------------|---------------|--------------------|---------|---------|---------|---------|---------|---------|--------|---------------|
| WLCSP-1.22×0.83-6B | 7" | 9.5 | 0.91 | 1.31 | 0.71 | 4.0 | 4.0 | 2.0 | 8.0 | Q1 |
| TDFN-2×2-6AL | 7" | 9.5 | 2.30 | 2.30 | 1.10 | 4.0 | 4.0 | 2.0 | 8.0 | Q1 |

DD0001

PACKAGE INFORMATION

CARTON BOX DIMENSIONS



NOTE: The picture is only for reference. Please make the object as the standard.

KEY PARAMETER LIST OF CARTON BOX

| Reel Type | Length (mm) | Width (mm) | Height (mm) | Pizza/Carton |
|-------------|-------------|------------|-------------|--------------|
| 7" (Option) | 368 | 227 | 224 | 8 |
| 7" | 442 | 410 | 224 | 18 |

DD0002