

GENERAL DESCRIPTION

The SGM25662 is a small single channel load switch with ultra-low R_{ON} . The switch controlled by the ON pin operates from 2.5V to 5.5V supply voltage. It can be used in processor rails where voltage dropout is tightly required.

The device is designed with soft-start circuit to cope with inrush currents when large capacitive loads are connected.

The device integrates a 198Ω pull-down resistor for output discharge when the switch is shut down by ON to reduce the total solution size.

The SGM25662 is available in a Green TDFN-3×3-8EL package.

FEATURES

- **Single Channel Load Switch**
- **VIN Voltage Range: 0.8V to 5.5V**
- **Bias Voltage Range: 2.5V to 5.5V**
- **Ultra-Low On-Resistance:**
 $R_{ON} = 4.3m\Omega$ at $V_{IN} = 5V$ ($V_{BIAS} = 5V$)
- **10A Maximum Continuous Switch Current**
- **VBIAS Quiescent Current: 12.0μA for $V_{BIAS} = 5V$**
- **VBIAS Shutdown Current: 1.1μA for $V_{BIAS} = 5V$**
- **Low Threshold 1.2V or Higher GPIO**
- **Rise Time: 2350μs at $V_{IN} = 5V$ ($V_{BIAS} = 5V$)**
- **Quick Output Discharge (QOD)**
- **Available in a Green TDFN-3×3-8EL Package**

APPLICATIONS

Servers
 Medical
 Telecom Systems
 Computing
 Industrial Systems
 High Current Voltage Rails

TYPICAL APPLICATION

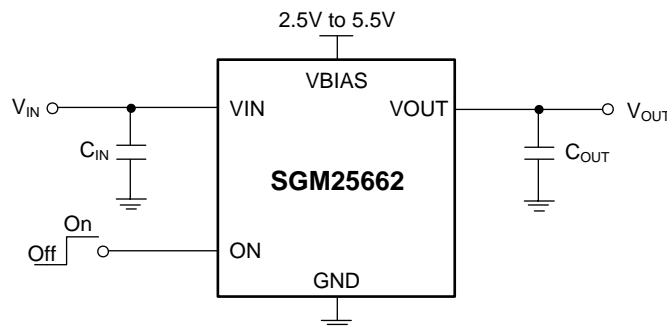

Figure 1. Typical Application Circuit

PACKAGE/ORDERING INFORMATION

MODEL	PACKAGE DESCRIPTION	SPECIFIED TEMPERATURE RANGE	ORDERING NUMBER	PACKAGE MARKING	PACKING OPTION
SGM25662	TDFN-3x3-8EL	-40°C to +105°C	SGM25662GTGB8G/TR	SGM 0MXGB XXXXX	Tape and Reel, 4000

MARKING INFORMATION

NOTE: XXXXX = Date Code, Trace Code and Vendor Code.

XXXXX

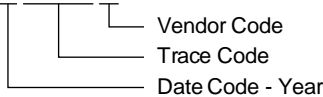

Green (RoHS & HSF): SG Micro Corp defines "Green" to mean Pb-Free (RoHS compatible) and free of halogen substances. If you have additional comments or questions, please contact your SGMICRO representative directly.

ABSOLUTE MAXIMUM RATINGS

Input Voltage Range, V_{IN}	-0.3V to 6V
Bias Voltage Range, V_{BIAS}	-0.3V to 6V
Output Voltage Range, V_{OUT}	-0.3V to 6V
ON Pin Voltage Range, V_{ON}	-0.3V to 6V
Maximum Continuous Switch Current, I_{MAX} , $T_A = +70^\circ\text{C}$	10A
Maximum Pulsed Switch Current, Pulse < 300μs, 2% Duty Cycle, I_{PLS}	12A
Package Thermal Resistance	
TDFN-3x3-8EL, θ_{JA}	51.5°C/W
TDFN-3x3-8EL, θ_{JB}	22.4°C/W
TDFN-3x3-8EL, $\theta_{JC (TOP)}$	44.6°C/W
TDFN-3x3-8EL, $\theta_{JC (BOT)}$	17.5°C/W
Junction Temperature	+150°C
Storage Temperature Range	-65°C to +150°C
Lead Temperature (Soldering, 10s)	+260°C
ESD Susceptibility	
HBM	2000V
CDM	1000V

RECOMMENDED OPERATING CONDITIONS

Input Voltage Range, V_{IN}	0.8V to V_{BIAS}
Bias Voltage Range, V_{BIAS}	2.5V to 5.5V
ON Pin Voltage Range, V_{ON}	0V to 5.5V
Output Voltage Range, V_{OUT}	V_{IN}
Input Capacitor, C_{IN}	> 1μF
ON Pin Input High Voltage, V_{IH}	1.2V to 5.5V
ON Pin Input Low Voltage, V_{IL}	0V to 0.5V
Operating Junction Temperature Range	-40°C to +125°C
Operating Ambient Temperature Range	-40°C to +105°C

OVERSTRESS CAUTION

Stresses beyond those listed in Absolute Maximum Ratings may cause permanent damage to the device. Exposure to absolute maximum rating conditions for extended periods may affect reliability. Functional operation of the device at any conditions beyond those indicated in the Recommended Operating Conditions section is not implied.

ESD SENSITIVITY CAUTION

This integrated circuit can be damaged if ESD protections are not considered carefully. SGMICRO recommends that all integrated circuits be handled with appropriate precautions. Failure to observe proper handling and installation procedures can cause damage. ESD damage can range from subtle performance degradation to complete device failure. Precision integrated circuits may be more susceptible to damage because even small parametric changes could cause the device not to meet the published specifications.

DISCLAIMER

SG Micro Corp reserves the right to make any change in circuit design, or specifications without prior notice.

PIN CONFIGURATION

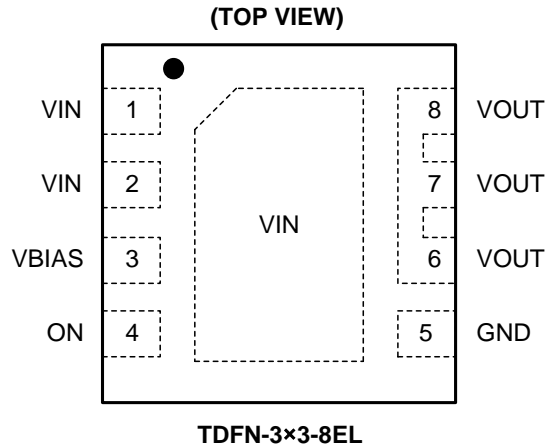

PIN DESCRIPTION

PIN	NAME	FUNCTION
1, 2	VIN	Switch Input Voltage Pin.
3	VBIAS	Power Supply Input for the Device.
4	ON	Enable Input. Logic high sets the device active, and logic low disables it and turns it into shutdown mode. Do not leave this pin floating.
5	GND	Ground.
6, 7, 8	VOUT	Output Voltage.
Exposed Pad	VIN	Switch Input Voltage.

ELECTRICAL CHARACTERISTICS(V_{BIAS} = 5V, T_A = -40°C to +105°C, typical values are at T_A = +25°C, unless otherwise noted.)

PARAMETER	SYMBOL	CONDITIONS		MIN	TYP	MAX	UNITS	
Power Supplies and Currents								
VBIAS Quiescent Current	I _{Q_BIAS}	I _{OUT} = 0A, V _{ON} = 5V, V _{IN} = V _{BIAS}		T _A = -40°C to +85°C		12.0	17.0	μA
				T _A = -40°C to +105°C			17.0	
VBIAS Shutdown Current	I _{SD_BIAS}	V _{ON} = 0V, V _{OUT} = 0V		T _A = -40°C to +85°C		1.1	1.9	μA
				T _A = -40°C to +105°C			1.9	
VIN Shutdown Current	I _{SD_VIN}	V _{ON} = 0V, V _{OUT} = 0V	V _{IN} = 5V	T _A = +25°C			0.1	μA
				T _A = -40°C to +85°C			0.7	
				T _A = -40°C to +105°C			1.7	
			V _{IN} = 3.3V	T _A = +25°C			0.1	
				T _A = -40°C to +85°C			0.7	
				T _A = -40°C to +105°C			1.7	
			V _{IN} = 1.8V	T _A = +25°C			0.1	
				T _A = -40°C to +85°C			0.7	
				T _A = -40°C to +105°C			1.7	
			V _{IN} = 1.05V	T _A = +25°C			0.1	
				T _A = -40°C to +85°C			0.7	
				T _A = -40°C to +105°C			1.7	
V _{IN} = 0.8V	T _A = +25°C			0.1				
	T _A = -40°C to +85°C			0.7				
	T _A = -40°C to +105°C			1.7				
ON Terminal Input Leakage Current	I _{ON}	V _{ON} = 5.5V		T _A = -40°C to +85°C			0.15	μA
				T _A = -40°C to +105°C			0.20	
ON Pin Hysteresis	V _{HYS_ON}	V _{BIAS} = V _{IN}				180		mV
Resistance Characteristics								
On-Resistance	R _{ON}	I _{OUT} = 500mA, V _{BIAS} = 5.0V	V _{IN} = 5V	T _A = +25°C		4.3	5.0	mΩ
				T _A = -40°C to +85°C			6.2	
				T _A = -40°C to +105°C			6.7	
			V _{IN} = 3.3V	T _A = +25°C		4.1	4.8	
				T _A = -40°C to +85°C			5.9	
				T _A = -40°C to +105°C			6.4	
			V _{IN} = 2.5V	T _A = +25°C		4.1	4.8	
				T _A = -40°C to +85°C			5.9	
				T _A = -40°C to +105°C			6.4	
			V _{IN} = 1.8V	T _A = +25°C		4.1	4.8	
				T _A = -40°C to +85°C			5.9	
				T _A = -40°C to +105°C			6.4	
V _{IN} = 1.05V	T _A = +25°C		4.1	4.8				
	T _A = -40°C to +85°C			5.9				
	T _A = -40°C to +105°C			6.4				
V _{IN} = 0.8V	T _A = +25°C		4.1	4.8				
	T _A = -40°C to +85°C			5.9				
	T _A = -40°C to +105°C			6.4				
Output Pull-Down Resistance	R _{PD}	V _{IN} = 5V, V _{ON} = 0V, V _{OUT} = 1V		T _A = -40°C to +105°C		198	215	Ω

ELECTRICAL CHARACTERISTICS (Continued)

(V_{BIAS} = 2.5V, T_A = -40°C to +105°C, typical values are at T_A = +25°C, unless otherwise noted.)

PARAMETER	SYMBOL	CONDITIONS		MIN	TYP	MAX	UNITS	
Power Supplies and Currents								
VBIAS Quiescent Current	I _{Q_BIAS}	I _{OUT} = 0A, V _{ON} = 5V, V _{IN} = V _{BIAS}		T _A = -40°C to +85°C T _A = -40°C to +105°C	9.5	14.0	μA	
VBIAS Shutdown Current	I _{SD_BIAS}	V _{ON} = 0V, V _{OUT} = 0V		T _A = -40°C to +85°C T _A = -40°C to +105°C	0.4	0.9		μA
VIN Shutdown Current	I _{SD_VIN}	V _{ON} = 0V, V _{OUT} = 0V	V _{IN} = 2.5V	T _A = +25°C		0.1	μA	
				T _A = -40°C to +85°C		0.7		
				T _A = -40°C to +105°C		1.7		
				T _A = +25°C		0.1		
				T _A = -40°C to +85°C		0.7		
				T _A = -40°C to +105°C		1.7		
			V _{IN} = 1.8V	T _A = +25°C		0.1		
				T _A = -40°C to +85°C		0.7		
				T _A = -40°C to +105°C		1.7		
				T _A = +25°C		0.1		
				T _A = -40°C to +85°C		0.7		
				T _A = -40°C to +105°C		1.7		
V _{IN} = 1.05V	T _A = +25°C		0.1					
	T _A = -40°C to +85°C		0.7					
	T _A = -40°C to +105°C		1.7					
	T _A = +25°C		0.1					
	T _A = -40°C to +85°C		0.7					
	T _A = -40°C to +105°C		1.7					
V _{IN} = 0.8V	T _A = +25°C		0.1					
	T _A = -40°C to +85°C		0.7					
	T _A = -40°C to +105°C		1.7					
	T _A = +25°C		0.1					
	T _A = -40°C to +85°C		0.7					
	T _A = -40°C to +105°C		1.7					
ON Terminal Input Leakage Current	I _{ON}	V _{ON} = 5.5V		T _A = -40°C to +85°C T _A = -40°C to +105°C		0.15	μA	
ON Pin Hysteresis	V _{HYS_ON}	V _{BIAS} = V _{IN}		T _A = +25°C	70			mV
Resistance Characteristics								
On-Resistance	R _{ON}	I _{OUT} = 500mA, V _{BIAS} = 2.5V	V _{IN} = 2.5V	T _A = +25°C		4.5	5.2	mΩ
				T _A = -40°C to +85°C		6.2		
				T _A = -40°C to +105°C		6.7		
				T _A = +25°C		4.4	5.1	
				T _A = -40°C to +85°C		6.1		
				T _A = -40°C to +105°C		6.6		
			V _{IN} = 1.8V	T _A = +25°C		4.2	4.9	
				T _A = -40°C to +85°C		5.9		
				T _A = -40°C to +105°C		6.4		
				T _A = +25°C		4.2	4.9	
				T _A = -40°C to +85°C		5.9		
				T _A = -40°C to +105°C		6.4		
V _{IN} = 1.05V	T _A = +25°C		4.2	4.9				
	T _A = -40°C to +85°C		5.9					
	T _A = -40°C to +105°C		6.4					
	T _A = +25°C		4.2	4.9				
	T _A = -40°C to +85°C		5.9					
	T _A = -40°C to +105°C		6.4					
V _{IN} = 0.8V	T _A = +25°C		4.2	4.9				
	T _A = -40°C to +85°C		5.9					
	T _A = -40°C to +105°C		6.4					
	T _A = +25°C		4.2	4.9				
	T _A = -40°C to +85°C		5.9					
	T _A = -40°C to +105°C		6.4					
Output Pull-Down Resistance	R _{PD}	V _{IN} = 2.5V, V _{ON} = 0V, V _{OUT} = 1V		T _A = -40°C to +105°C	201	218	Ω	

SWITCHING CHARACTERISTICS

Refer to Figure 2 for the external components used in the switch characteristics test conditions. The depicted switching characteristics are valid only when V_{IN} and V_{BIAS} are steady before the ON pin is asserted high during power-up.

PARAMETER	SYMBOL	CONDITIONS	MIN	TYP	MAX	UNITS
$V_{IN} = 5V, V_{ON} = V_{BIAS} = 5V, T_A = +25^\circ C$, unless otherwise noted.						
Turn-On Time	t_{ON}	$R_{OUT} = 10\Omega, C_{OUT} = 0.1\mu F$		2200		μs
Turn-Off Time	t_{OFF}			5		
V_{OUT} Rise Time	t_R			2350		
V_{OUT} Fall Time	t_F			2		
Delay Time	t_D			1030		
$V_{IN} = 3.3V, V_{ON} = V_{BIAS} = 5V, T_A = +25^\circ C$, unless otherwise noted.						
Turn-On Time	t_{ON}	$R_{OUT} = 10\Omega, C_{OUT} = 0.1\mu F$		1710		μs
Turn-Off Time	t_{OFF}			5		
V_{OUT} Rise Time	t_R			1560		
V_{OUT} Fall Time	t_F			2		
Delay Time	t_D			930		
$V_{IN} = 0.8V, V_{ON} = V_{BIAS} = 5V, T_A = +25^\circ C$, unless otherwise noted.						
Turn-On Time	t_{ON}	$R_{OUT} = 10\Omega, C_{OUT} = 0.1\mu F$		990		μs
Turn-Off Time	t_{OFF}			5		
V_{OUT} Rise Time	t_R			440		
V_{OUT} Fall Time	t_F			2		
Delay Time	t_D			780		
$V_{IN} = 2.5V, V_{ON} = 5V, V_{BIAS} = 2.5V, T_A = +25^\circ C$, unless otherwise noted.						
Turn-On Time	t_{ON}	$R_{OUT} = 10\Omega, C_{OUT} = 0.1\mu F$		1520		μs
Turn-Off Time	t_{OFF}			7		
V_{OUT} Rise Time	t_R			1220		
V_{OUT} Fall Time	t_F			2		
Delay Time	t_D			910		
$V_{IN} = 1.8V, V_{ON} = 5V, V_{BIAS} = 2.5V, T_A = +25^\circ C$, unless otherwise noted.						
Turn-On Time	t_{ON}	$R_{OUT} = 10\Omega, C_{OUT} = 0.1\mu F$		1310		μs
Turn-Off Time	t_{OFF}			7		
V_{OUT} Rise Time	t_R			900		
V_{OUT} Fall Time	t_F			2		
Delay Time	t_D			870		
$V_{IN} = 0.8V, V_{ON} = 5V, V_{BIAS} = 2.5V, T_A = +25^\circ C$, unless otherwise noted.						
Turn-On Time	t_{ON}	$R_{OUT} = 10\Omega, C_{OUT} = 0.1\mu F$		1020		μs
Turn-Off Time	t_{OFF}			8		
V_{OUT} Rise Time	t_R			460		
V_{OUT} Fall Time	t_F			2		
Delay Time	t_D			800		

PARAMETER MEASUREMENT INFORMATION

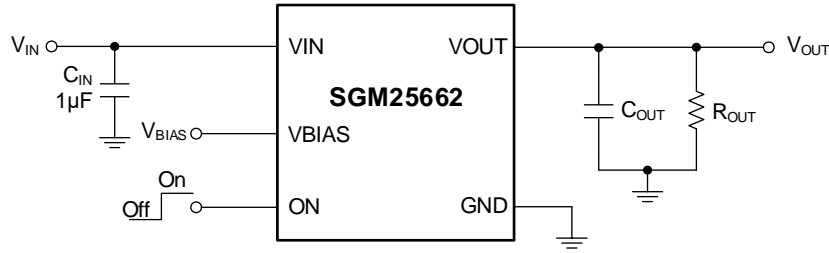

Figure 2. Test Circuit

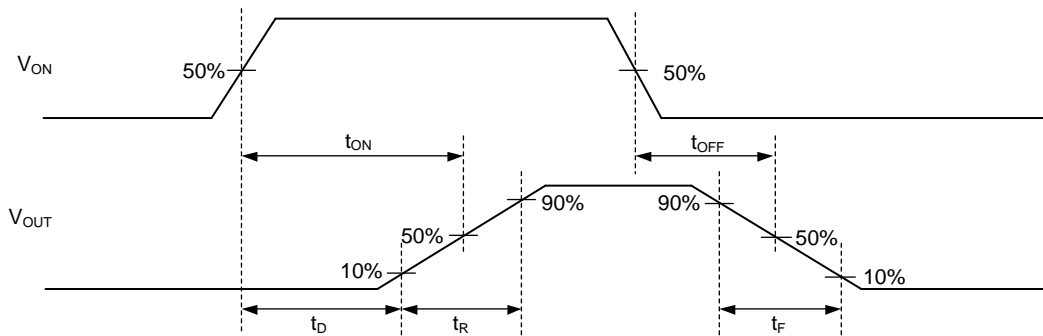

Figure 3. Turn-On and Turn-Off Waveforms

FUNCTIONAL BLOCK DIAGRAM

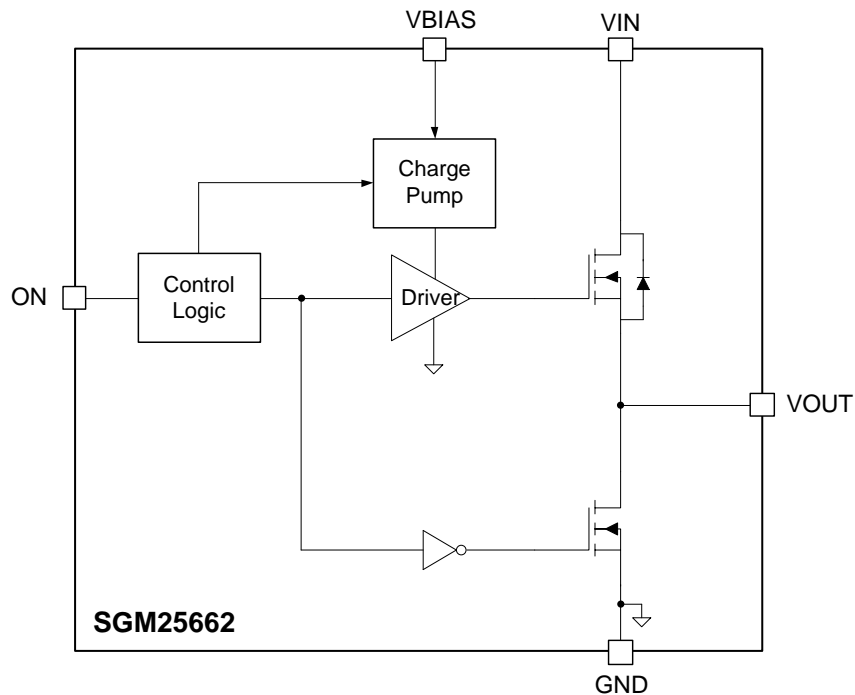
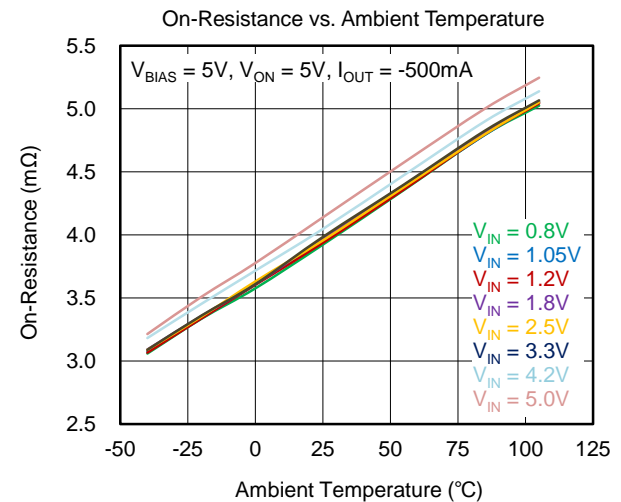
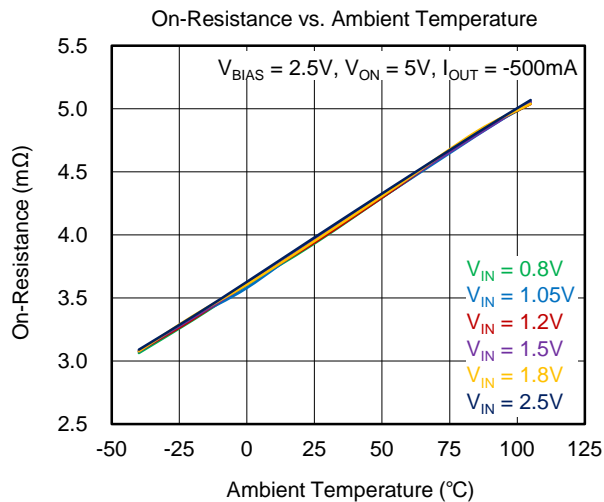
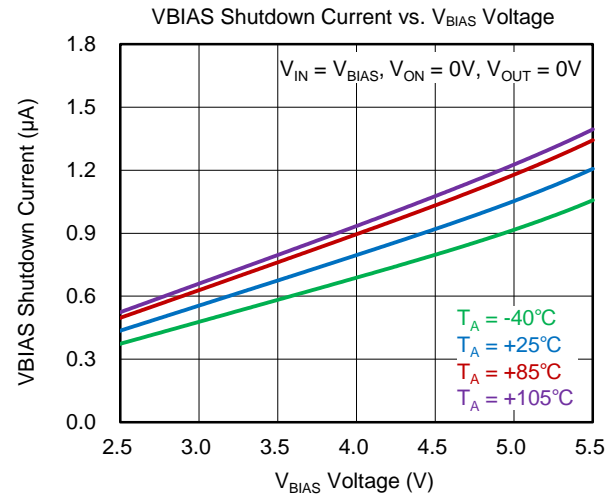
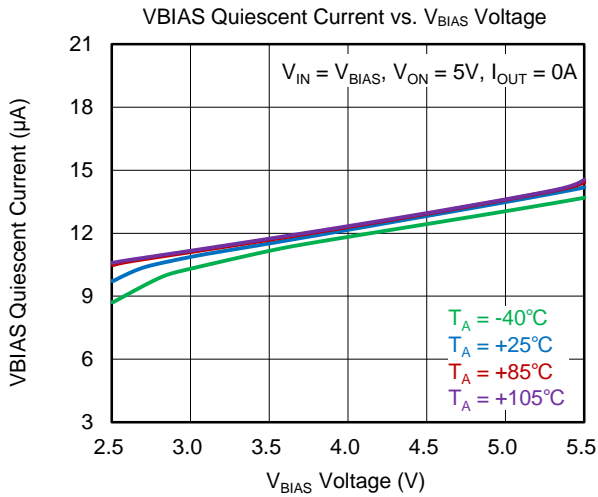
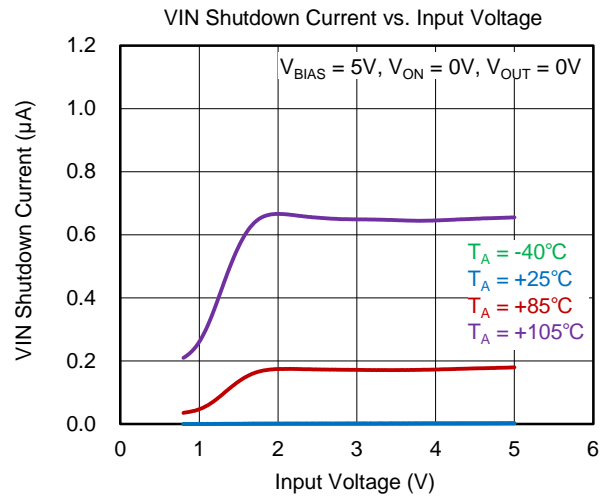
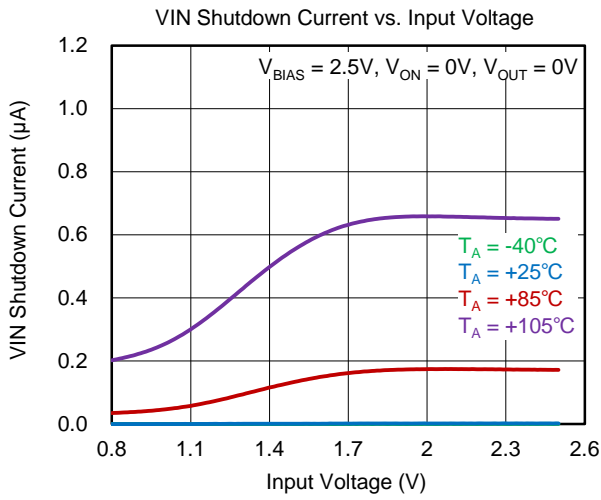
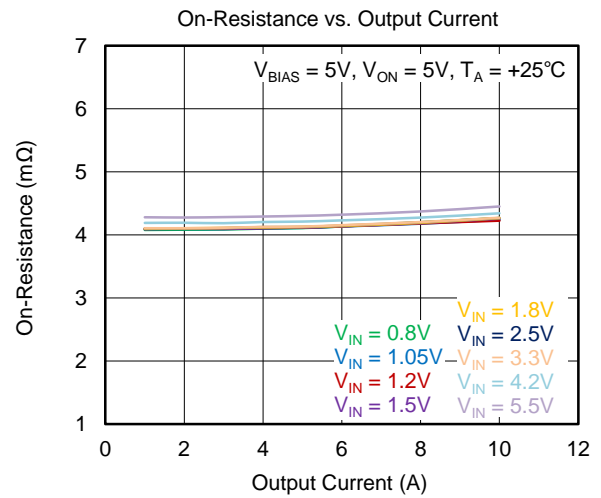
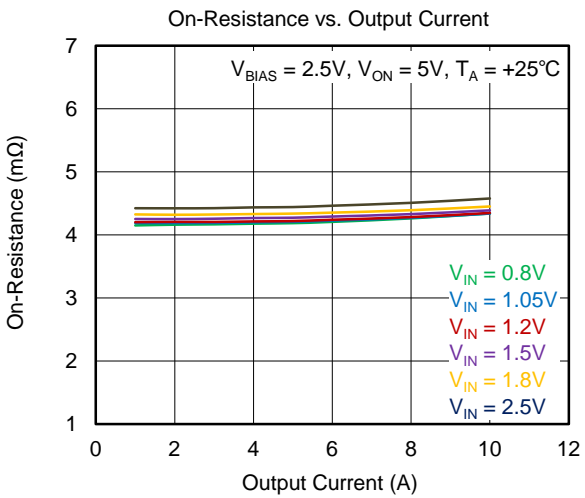
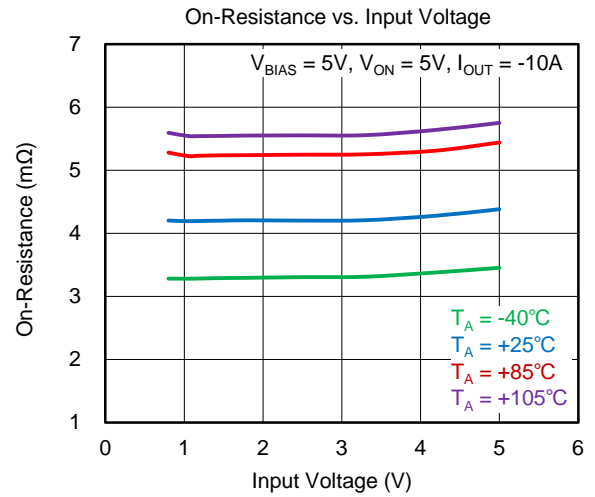
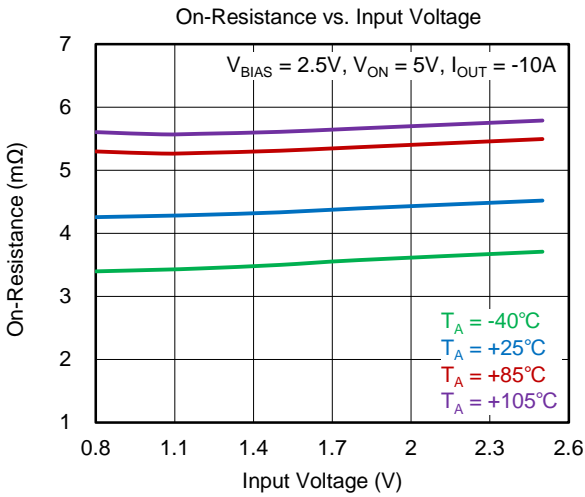
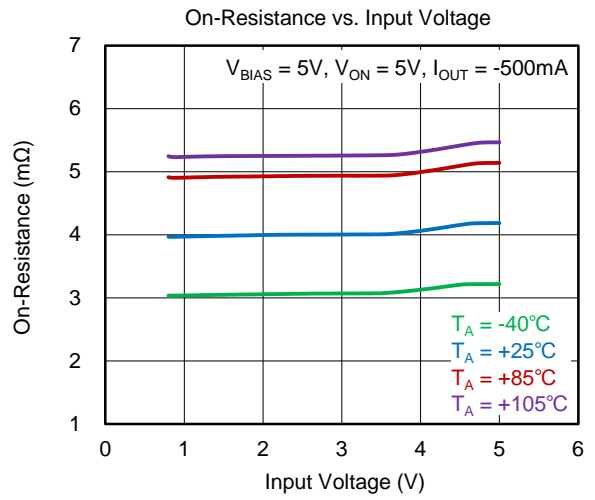
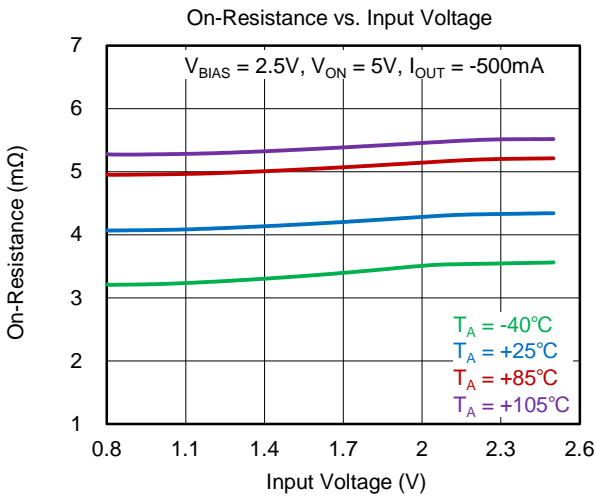

Figure 4. Block Diagram

TYPICAL PERFORMANCE CHARACTERISTICS



TYPICAL PERFORMANCE CHARACTERISTICS (continued)



TYPICAL PERFORMANCE CHARACTERISTICS (continued)

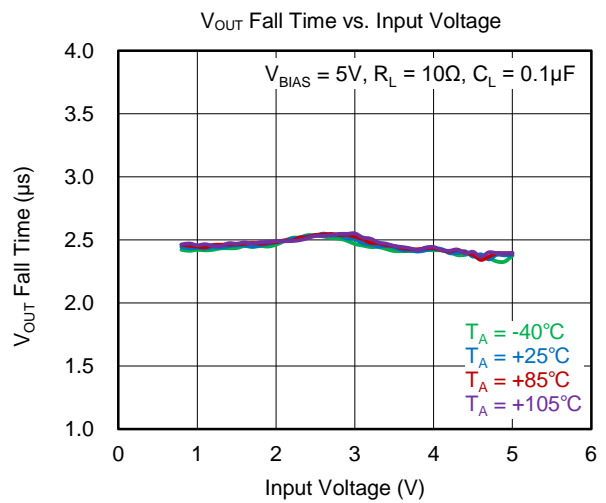
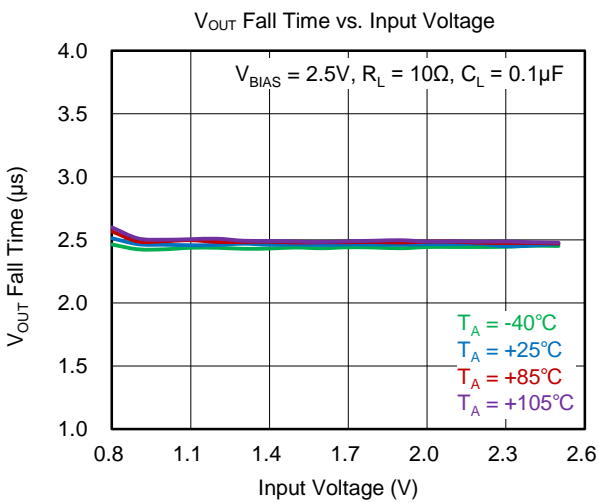
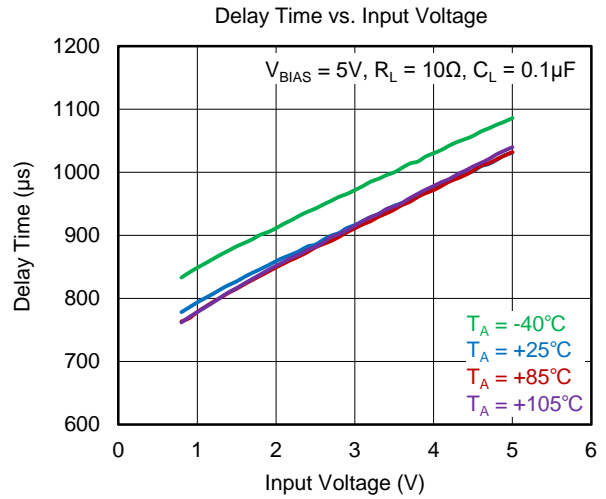
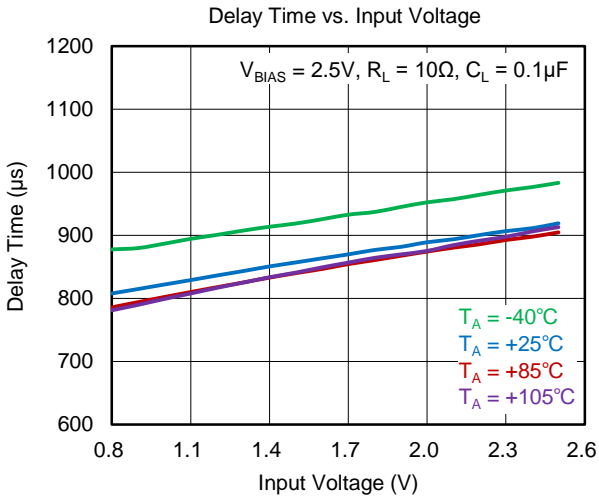
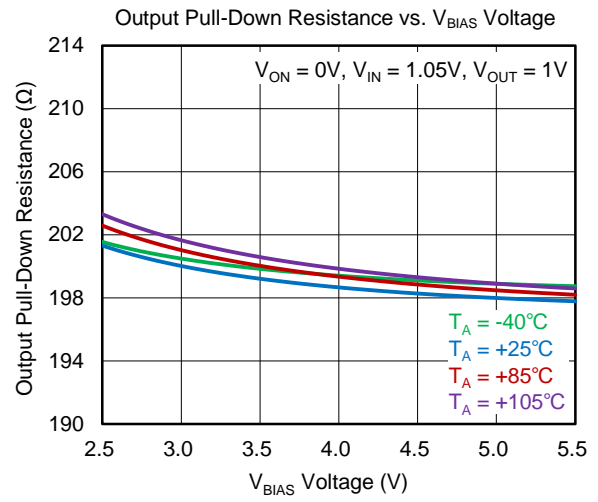
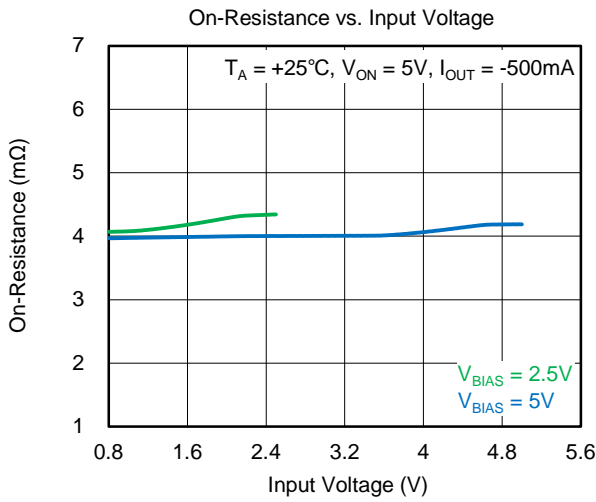

TYPICAL PERFORMANCE CHARACTERISTICS (continued)

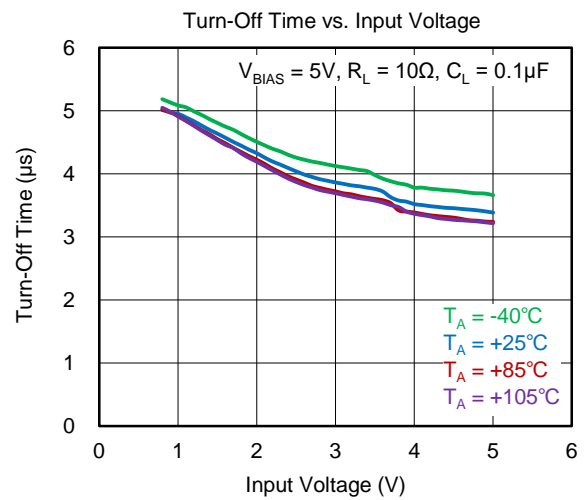
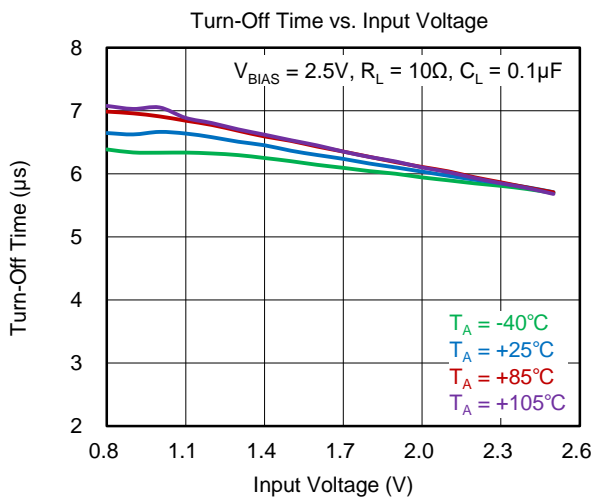
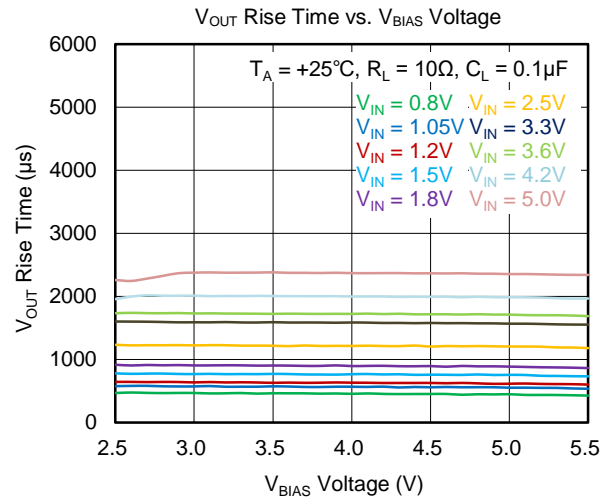
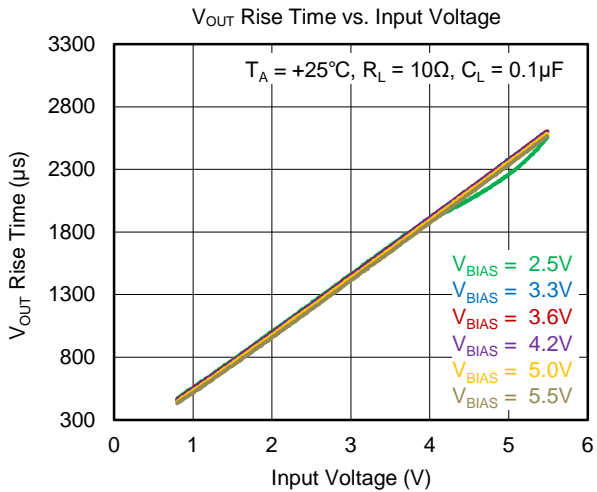
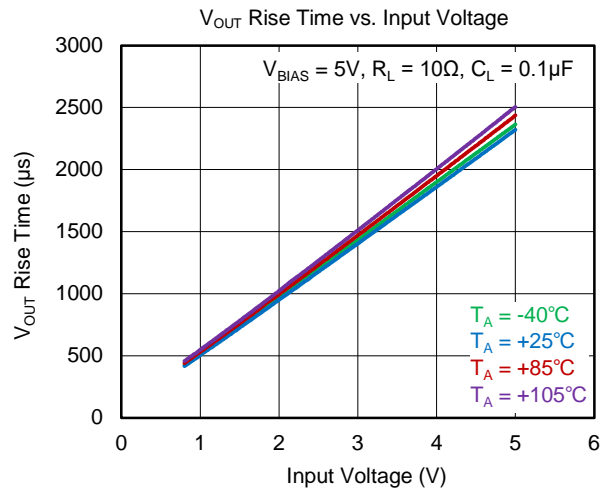
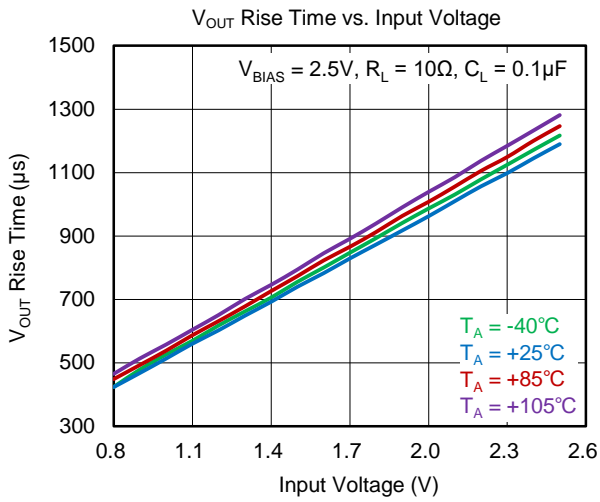

TYPICAL PERFORMANCE CHARACTERISTICS (continued)

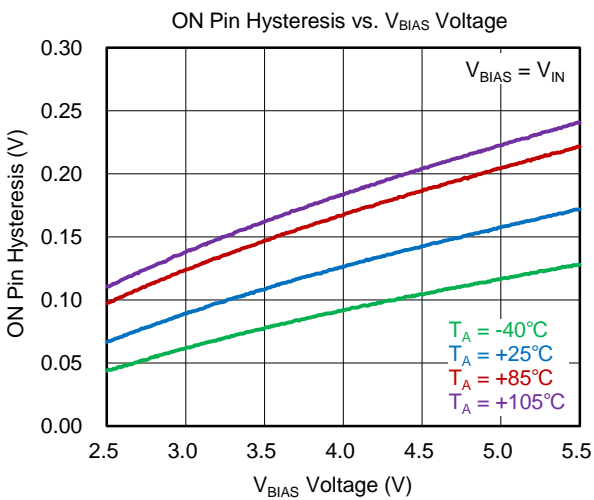
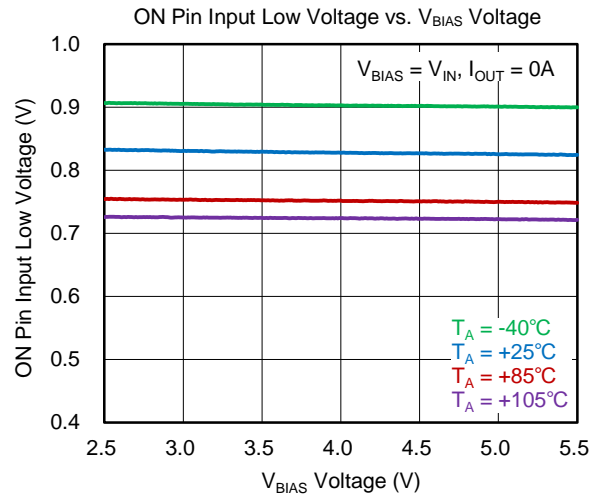
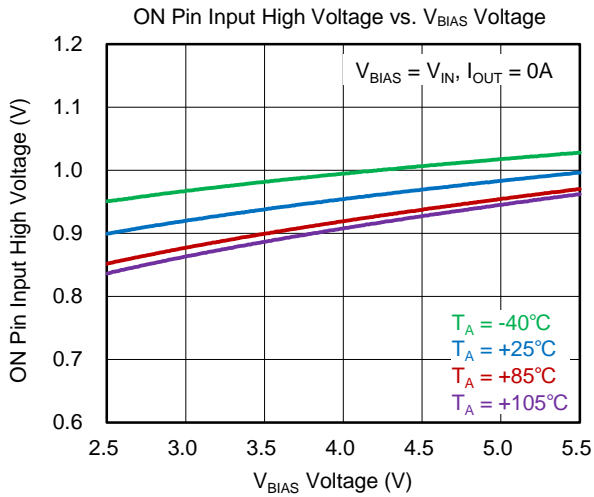
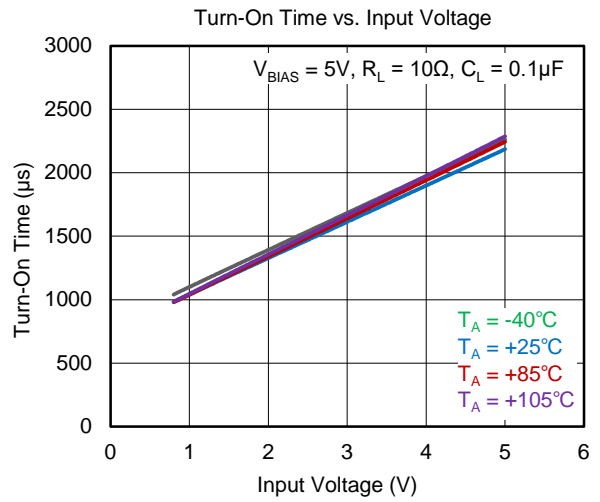
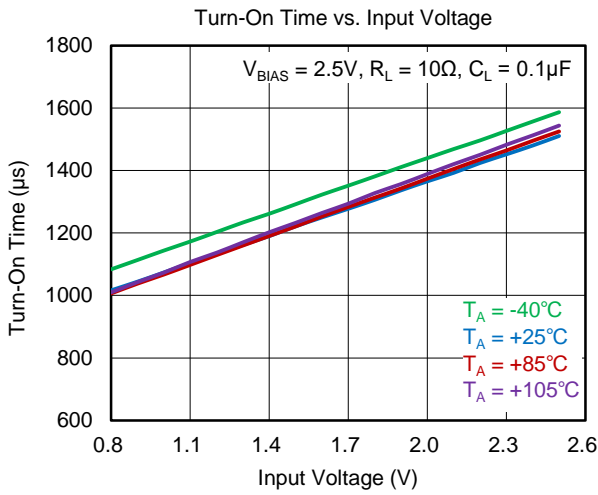

DETAILED DESCRIPTION

Input and Output

V_{IN} should be connected to the power source that is the power supply of the loads and the internal logic circuit is provided by V_{BIAS}. Normally, load current flows from V_{IN} to V_{OUT}.

Supply Filter Capacitor

It is recommended to use a 10μF capacitor between V_{IN} and GND close to the device pins. It can limit the voltage drop of the input supply. Larger C_{IN} can reduce voltage dip in high current applications. Without an input capacitor, short-circuit at the output will cause the input voltage to ring, which may destroy the chip's internal circuitry when the input transient voltage exceeds the absolute maximum supply voltage.

Output Filter Capacitor

To reduce EMI, improve the transient performance, and minimize negative effects of resistance and inductance between the bypass capacitor and the downstream connector, a low-ESR 10μF ceramic capacitor between V_{OUT} and GND is recommended as a standard bypass method. If the output port is connected to the load through a long cable, the parasitic inductance of the cable may cause voltage to ring, whose negative ringing may damage the chip, so an anti-parallel Schottky diode such as BAT54 is recommended to connect in parallel with the output.

V_{BIAS} Voltage Range

When V_{IN} < V_{BIAS}, the device gets the best R_{ON} performance. If V_{IN} > V_{BIAS}, the device will show a larger R_{ON} than the value in the electrical characteristics table even though it still work. Ensure that V_{IN} and V_{BIAS} are set to appropriate values, otherwise performance will not be guaranteed.

Soft-Start

The soft-start feature is used to limit inrush current during start-up or hot-plug events so that the device can cope with inrush current when connected to large capacitive loads.

Output Discharge

The SGM25662 integrates the output discharge feature. When the ON pin is pulled low, a discharge resistance with a typical value of 198Ω is connected between the V_{OUT} and GND. This resistance pulls down the output and prevents it from floating when the device is disabled.

APPLICATION INFORMATION

Power Dissipation

Assuming a given ambient temperature and an output current, the maximum allowable power dissipation is calculated by:

$$P_{D(MAX)} = \frac{T_{J(MAX)} - T_A}{R_{\theta JA}} \quad (1)$$

where $P_{D(MAX)}$ is the maximum power dissipation. $T_{J(MAX)}$ is the maximum operating junction temperature. T_A is the operating ambient temperature. θ_{JA} is junction to air thermal impedance.

Please note that the thermal vias are placed under the exposed pad of the device, thus allowing for thermal dissipation away from the device.

Inrush Current

The inrush current can be caused by the output capacitor. Use Equation 2 to estimate the inrush current.

$$I_{INRUSH} = C_{OUT} \times \frac{dV_{OUT}}{dt} \quad (2)$$

where I_{INRUSH} is the value of inrush current caused by C_{OUT} . C_{OUT} is the output capacitance value. dV_{OUT} is the rising change value of V_{OUT} after the device is enabled.

dt is the time taken by the device to increase V_{OUT} after the device is enabled.

Select the appropriate C_{OUT} to ensure the stable operation of the device.

PCB Layout Guidelines

A reasonable PCB layout is critical to the stable performance of the SGM25662. For best results, follow the guidelines below.

- ◆ Keep the power traces as short and wide as possible, and use at least 2 ounces of copper.
- ◆ Placing a ground plane under all circuits to reduce resistance and inductance will improve DC and transient performances.
- ◆ Ensure that the input decoupling capacitors on VIN have a minimal trace length to VIN and GND.
- ◆ Place the output capacitors as close to the SGM25662 as possible to minimize the effect of PCB parasitic inductance.
- ◆ The VBIAS pin requires a ceramic capacitor with low ESR for bypass. The recommended bypass capacitor is 0.1μF with X5R or X7R dielectric.

REVISION HISTORY

NOTE: Page numbers for previous revisions may differ from page numbers in the current version.

Changes from Original (JUNE 2024) to REV.A	Page
Changed from product preview to production data.....	All

PACKAGE OUTLINE DIMENSIONS

TDFN-3x3-8EL

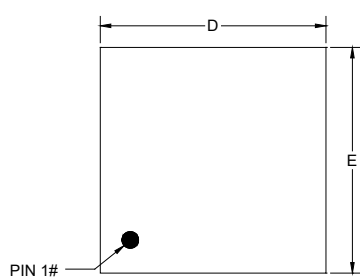

TOP VIEW

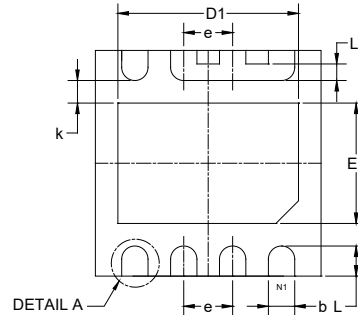

BOTTOM VIEW

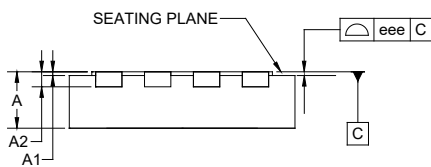

SIDE VIEW

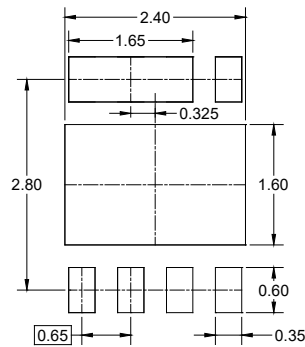
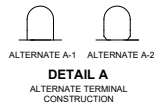

RECOMMENDED LAND PATTERN (Unit: mm)

Symbol	Dimensions In Millimeters		
	MIN	MOD	MAX
A	0.700	-	0.800
A1	0.000	-	0.050
A2	0.200 REF		
b	0.300	-	0.400
D	2.900	-	3.100
E	2.900	-	3.100
D1	2.300	-	2.500
E1	1.500	-	1.700
e	0.650 BSC		
L	0.300	-	0.500
L1	0.120	-	0.320
k	0.300 REF		
eee	0.080		

NOTE: This drawing is subject to change without notice.

PACKAGE INFORMATION

TAPE AND REEL INFORMATION

REEL DIMENSIONS



TAPE DIMENSIONS



NOTE: The picture is only for reference. Please make the object as the standard.

KEY PARAMETER LIST OF TAPE AND REEL

Package Type	Reel Diameter	Reel Width W1 (mm)	A0 (mm)	B0 (mm)	K0 (mm)	P0 (mm)	P1 (mm)	P2 (mm)	W (mm)	Pin1 Quadrant
TDFN-3×3-8EL	13"	12.4	3.30	3.30	1.10	4.0	8.0	2.0	12.0	Q2

DD0001

PACKAGE INFORMATION

CARTON BOX DIMENSIONS



NOTE: The picture is only for reference. Please make the object as the standard.

KEY PARAMETER LIST OF CARTON BOX

Reel Type	Length (mm)	Width (mm)	Height (mm)	Pizza/Carton
13"	386	280	370	5

DD0002