



SGM48209

120V Boot, 4A Peak, High Frequency High-side and Low-side Driver

GENERAL DESCRIPTION

The SGM48209 is a half-bridge MOSFET driver with 4A peak source and sink output current capability, which makes it possible to drive large power MOSFETs with minimized switching losses. The two channels of high-side and low-side are totally independent with 3ns (TYP) delay matching between the turn-on and turn-off of each other.

The maximum withstanding voltage of the input stage of SGM48209 is 20V. Due to the -10V_{DC} voltage endurance capacity of its input stage, the driver has enhanced robustness and can be interfaced to pulse transformers directly without using rectifier diodes. With a wide input hysteresis, the device can receive analog or digital PWM signals with improved noise immunity.

A 120V rated bootstrap diode is integrated internally to save the external diode and reduce PCB dimension size.

Under-voltage lockout (UVLO) is integrated in both the high-side and the low-side drivers. The output of each channel is forced low if the corresponding driving voltage falls below the specified threshold.

The SGM48209 is available in Green SOIC-8 and TDFN-4×4-8AL packages.

FEATURES

- **Wide Operating Range: 8V to 17V**
- **Drive Two N-MOSFETs Configured in Half Bridge**
- **Maximum Blocking Voltage: 120V DC**
- **Integrated Internal Bootstrap Diode for Cost Saving**
- **4A Peak Sink and Source Currents**
- **-10V to 20V Tolerance of Input Pins**
- **COMS/TTL Compatible Inputs**
- **6.5ns (TYP) Rise Time and 4.5ns (TYP) Fall Time with 1000pF Load**
- **Propagation Delay Time: 31ns (TYP)**
- **Delay Matching: 3ns (TYP)**
- **UVLO Functions for Both High-side and Low-side Drivers**
- **-40°C to +140°C Operating Junction Temperature Range**
- **Available in Green SOIC-8 and TDFN-4×4-8AL Packages**

APPLICATIONS

Power Converters in 48V or Lower Systems Used in Telecom, Datacom, Portable Storage, etc.
Half-Bridge, Full-Bridge, Push-Pull, Synchronous-Buck and Forward Converters
Synchronous Rectifiers
Class-D Audio Amplifiers

PACKAGE/ORDERING INFORMATION

MODEL	PACKAGE DESCRIPTION	SPECIFIED TEMPERATURE RANGE	ORDERING NUMBER	PACKAGE MARKING	PACKING OPTION
SGM48209	SOIC-8	-40°C to +140°C	SGM48209XS8G/TR	SGM 48209XS8 XXXXX	Tape and Reel, 4000
	TDFN-4x4-8AL	-40°C to +140°C	SGM48209XTGW8G/TR	SGM48209 XTGW8 XXXXX	Tape and Reel, 3000

MARKING INFORMATION

NOTE: XXXXX = Date Code, Trace Code and Vendor Code.

SOIC-8/TDFN-4x4-8AL

XXXXX

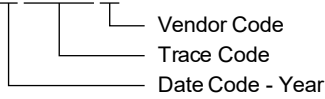

Green (RoHS & HSF): SG Micro Corp defines "Green" to mean Pb-Free (RoHS compatible) and free of halogen substances. If you have additional comments or questions, please contact your SGMICRO representative directly.

ABSOLUTE MAXIMUM RATINGS

Supply Voltage Range, $V_{DD}^{(1)}$, $V_{HB} - V_{HS}$	-0.3V to 20V
Input Voltages on LI and HI, V_{LI} , V_{HI}	-10V to 20V
LO Output Voltage, V_{LO}	-0.3V to $V_{DD} + 0.3V$
HO Output Voltage, V_{HO}	$V_{HS} - 0.3V$ to $V_{HB} + 0.3V$
HS Voltage, V_{HS}	
DC	-1V to 115V
Repetitive Pulse < 100ns	$-(24V - V_{DD})$ to 115V
HB Voltage, V_{HB}	-0.3V to 120V
Package Thermal Resistance	
SOIC-8, θ_{JA}	104.9°C/W
SOIC-8, θ_{JB}	50.7°C/W
SOIC-8, θ_{JC}	49.4°C/W
TDFN-4x4-8AL, θ_{JA}	32.6°C/W
TDFN-4x4-8AL, θ_{JB}	11.5°C/W
TDFN-4x4-8AL, $\theta_{JC(TOP)}$	33.9°C/W
TDFN-4x4-8AL, $\theta_{JC(BOT)}$	2.8°C/W
Junction Temperature	+150°C
Storage Temperature Range	-65°C to +150°C
Lead Temperature (Soldering, 10s).....	+260°C
ESD Susceptibility	
HBM.....	1500V
CDM	1000V

NOTE:

1. All voltages are with reference to VSS. Positive and negative currents are defined by flowing into and out of the specified terminal respectively.

RECOMMENDED OPERATING CONDITIONS

Supply Voltage Range, V_{DD} , $V_{HB} - V_{HS}$	8V to 17V
HS Voltage, V_{HS}	-1V to 105V
HB Voltage, V_{HB}	$V_{HS} + 8V$ to $V_{HS} + 17V$
HB Voltage, V_{HB}	$V_{DD} - 1V$ to 110V
HS Voltage Slew Rate	50V/ns (MAX)
Operating Junction Temperature Range	-40°C to +140°C

OVERSTRESS CAUTION

Stresses beyond those listed in Absolute Maximum Ratings may cause permanent damage to the device. Exposure to absolute maximum rating conditions for extended periods may affect reliability. Functional operation of the device at any conditions beyond those indicated in the Recommended Operating Conditions section is not implied.

ESD SENSITIVITY CAUTION

This integrated circuit can be damaged if ESD protections are not considered carefully. SGMICRO recommends that all integrated circuits be handled with appropriate precautions. Failure to observe proper handling and installation procedures can cause damage. ESD damage can range from subtle performance degradation to complete device failure. Precision integrated circuits may be more susceptible to damage because even small parametric changes could cause the device not to meet the published specifications.

DISCLAIMER

SG Micro Corp reserves the right to make any change in circuit design, or specifications without prior notice.

PIN CONFIGURATIONS

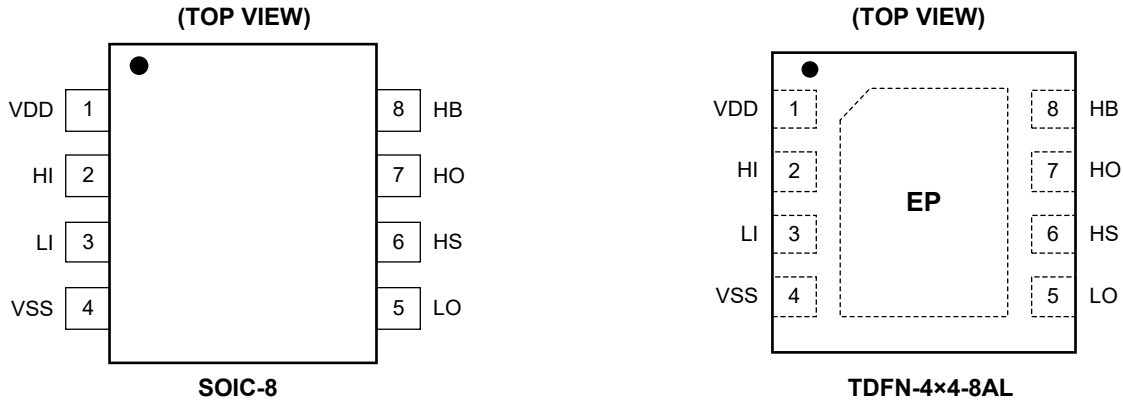

PIN DESCRIPTION

PIN	NAME	I/O ⁽¹⁾	FUNCTION
1	VDD	P	Positive Supply of the Whole Driver. A decoupling capacitor in the range of 0.22μF to 4.7μF is connected between VDD and VSS pins. ⁽²⁾
2	HI	I	Input of the High-side Driver. ⁽³⁾
3	LI	I	Input of the Low-side Driver. ⁽³⁾
4	VSS	G	Reference Ground of the Device.
5	LO	O	Output of the Low-side Driver. Connect this pin to the gate of the low-side MOSFET.
6	HS	P	Reference Ground of the High-side Output Stage. Tie this pin directly to the source of external high-side power MOSFET.
7	HO	O	Output of the High-side Driver. Connect this pin to the gate of the high-side MOSFET.
8	HB	P	High-side Bootstrap Supply. A bootstrap capacitor in the range of 0.022μF to 0.1μF is connected between HB and HS pins. The capacitor value varies with total gate charge of external MOSFET, the switching speed, as well as the voltage ripple criteria.
Exposed Pad ⁽⁴⁾	—	—	Thermal Pad. Connect directly to VSS with a large wide trace or polygon copper to achieve improved thermal conduction.

NOTES:

1. P: power supply, I: input, O: output, G: ground.
2. It is recommended to use the upper capacitance range for low temperature consideration.
3. Capacitors with typical value of 1nF to 10nF are recommended to be placed between HI/LI and VSS pins, which will be a great help to filter noise presented on these pins.
4. The exposed pad is internally connected to the substrate for thermal conduction and should be connected to the ground outside.

PACKAGE OUTLINE DIMENSIONS

SOIC-8

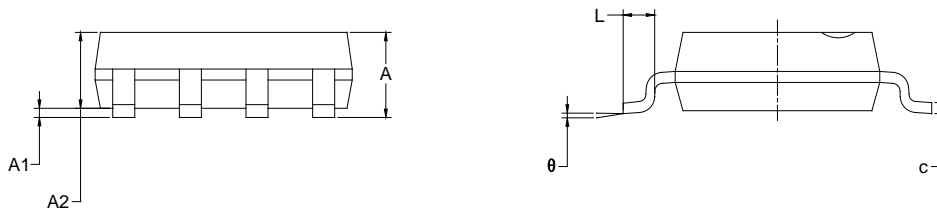
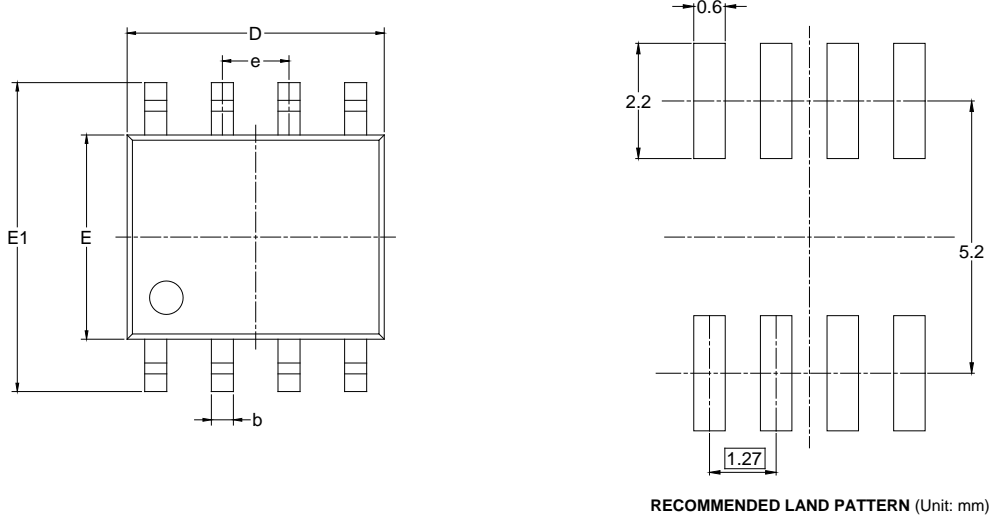

Symbol	Dimensions In Millimeters		Dimensions In Inches	
	MIN	MAX	MIN	MAX
A	1.350	1.750	0.053	0.069
A1	0.100	0.250	0.004	0.010
A2	1.350	1.550	0.053	0.061
b	0.330	0.510	0.013	0.020
c	0.170	0.250	0.006	0.010
D	4.700	5.100	0.185	0.200
E	3.800	4.000	0.150	0.157
E1	5.800	6.200	0.228	0.244
e	1.27 BSC		0.050 BSC	
L	0.400	1.270	0.016	0.050
θ	0°	8°	0°	8°

NOTES:
 1. Body dimensions do not include mode flash or protrusion.
 2. This drawing is subject to change without notice.

PACKAGE OUTLINE DIMENSIONS

TDFN-4x4-8AL

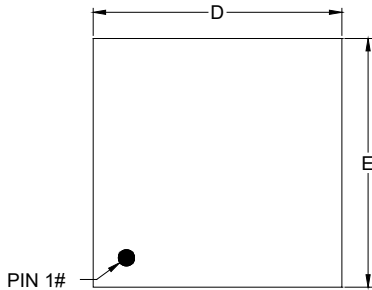

TOP VIEW

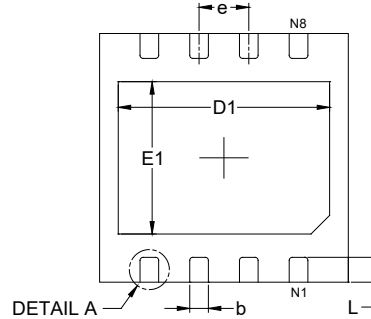

BOTTOM VIEW

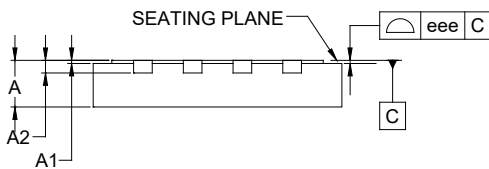

SIDE VIEW

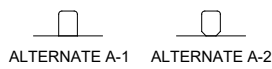

DETAIL A
ALTERNATE TERMINAL
CONSTRUCTION

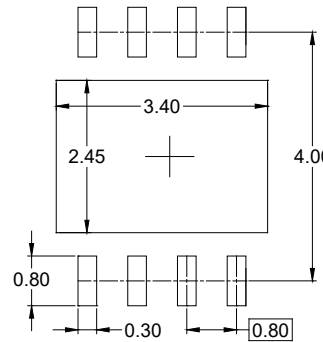

RECOMMENDED LAND PATTERN (Unit: mm)

Symbol	Dimensions In Millimeters		
	MIN	MOD	MAX
A	0.700	-	0.800
A1	0.000	-	0.050
A2	0.203 REF		
b	0.250	-	0.350
D	3.900	-	4.100
E	3.900	-	4.100
D1	3.300	-	3.500
E1	2.350	-	2.550
e	0.800 BSC		
L	0.300	-	0.500
eee	0.080		

NOTE: This drawing is subject to change without notice.

TAPE AND REEL INFORMATION

REEL DIMENSIONS



TAPE DIMENSIONS



NOTE: The picture is only for reference. Please make the object as the standard.

KEY PARAMETER LIST OF TAPE AND REEL

Package Type	Reel Diameter	Reel Width W1 (mm)	A0 (mm)	B0 (mm)	K0 (mm)	P0 (mm)	P1 (mm)	P2 (mm)	W (mm)	Pin1 Quadrant
SOIC-8	13"	12.4	6.40	5.40	2.10	4.0	8.0	2.0	12.0	Q1
TDFN-4×4-8AL	13"	12.4	4.30	4.30	1.10	4.0	8.0	2.0	12.0	Q2

DD0001

PACKAGE INFORMATION

CARTON BOX DIMENSIONS



NOTE: The picture is only for reference. Please make the object as the standard.

KEY PARAMETER LIST OF CARTON BOX

Reel Type	Length (mm)	Width (mm)	Height (mm)	Pizza/Carton
13"	386	280	370	5

DD0002