

GENERAL DESCRIPTION

The SGM862 family is a high-accuracy, low-power, and small size dual-channel voltage detector which can monitor two power rails respectively.

SENSEx is the input pin which can be programmed with an external resistor divider. There are four different hysteresis options of 0.6%, 1%, 5% or 10%.

OUTx is the open-drain corresponding output of SENSEx. OUTx goes low when the input voltage of SENSEx is lower than the falling threshold (V_{IT-}). OUTx goes high when the input voltage of SENSEx is higher than the rising threshold (V_{IT+}). The internal hysteresis of SENSEx has glitch immunity and ensures stable operation.

The device has low quiescent current of 1.1 μ A (TYP), high accuracy and small size, which is particularly suitable for system-monitoring of low power and portable equipment.

The SGM862 is available in Green UTDFN-1.45 \times 1-6AL and SOT-23-6 packages.

FEATURES

- **Supply Voltage Range: 1.65V to 6.5V**
- **High-Accuracy Threshold and Hysteresis:**
 - ◊ 1.5% at $V_{DD} = 1.65V$ to 3.3V
 - ◊ 1.7% at $V_{DD} = 1.65V$ to 6.5V
- **Low Quiescent Current: 1.1 μ A (TYP)**
- **Four Hysteresis Options: 0.6%, 1%, 5% and 10%**
- **Open-Drain Output**
- **Available in Green UTDFN-1.45 \times 1-6AL and SOT-23-6 Packages**

APPLICATIONS

- DSP or Microcontroller
- Notebooks and Tablet Computers
- Portable and Handheld Devices
- Battery-Powered Products
- Set-top Boxes
- Solid-State Drives (SSD)
- Building Automation
- Power Sequencing

TYPICAL APPLICATION

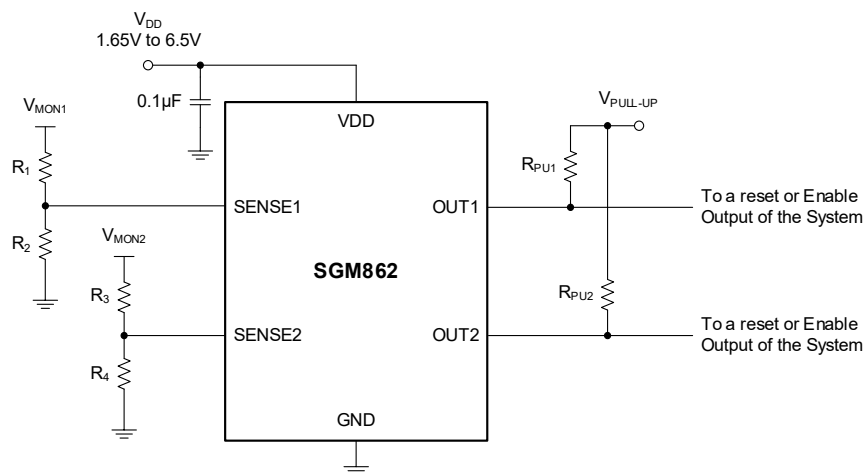

Figure 1. Typical Application Circuit

PACKAGE/ORDERING INFORMATION

MODEL	HYSTERESIS (%)	PACKAGE DESCRIPTION	SPECIFIED TEMPERATURE RANGE	ORDERING NUMBER	PACKAGE MARKING	PACKING OPTION
SGM862A	0.6	UTDFN-1.45×1-6AL	-40°C to +125°C	SGM862ABXUDL6G/TR	0DX	Tape and Reel, 5000
		SOT-23-6	-40°C to +125°C	SGM862ABXN6G/TR	06QXX	Tape and Reel, 3000
SGM862B	1	UTDFN-1.45×1-6AL	-40°C to +125°C	SGM862BBXUDL6G/TR	0EX	Tape and Reel, 5000
		SOT-23-6	-40°C to +125°C	SGM862BBXN6G/TR	0DOXX	Tape and Reel, 3000
SGM862C	5	UTDFN-1.45×1-6AL	-40°C to +125°C	SGM862CBXUDL6G/TR	0FX	Tape and Reel, 5000
		SOT-23-6	-40°C to +125°C	SGM862CBXN6G/TR	0DPXX	Tape and Reel, 3000
SGM862D	10	UTDFN-1.45×1-6AL	-40°C to +125°C	SGM862DBXUDL6G/TR	0GX	Tape and Reel, 5000
		SOT-23-6	-40°C to +125°C	SGM862DBXN6G/TR	0G4XX	Tape and Reel, 3000

MARKING INFORMATION

NOTE: X = Date Code. XX = Date Code.

UTDFN-1.45×1-6L

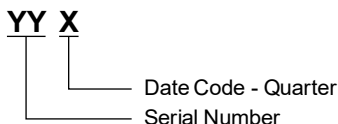

SOT-23-6

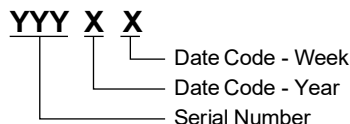

Green (RoHS & HSF): SG Micro Corp defines "Green" to mean Pb-Free (RoHS compatible) and free of halogen substances. If you have additional comments or questions, please contact your SGMICRO representative directly.

ABSOLUTE MAXIMUM RATINGS

VDD Voltage	-0.3V to 7V
OUT1, OUT2 Voltage	-0.3V to 7V
SENSE1, SENSE2 Voltage	-0.3V to 7V
OUT1, OUT2 Current	±20mA
Package Thermal Resistance	
UTDFN-1.45×1-6AL, θ_{JA}	241°C/W
SOT-23-6, θ_{JA}	225°C/W
Junction Temperature	+150°C
Storage Temperature Range	-65°C to +150°C
Lead Temperature (Soldering, 10s)	+260°C
ESD Susceptibility	
HBM	4000V
CDM	1000V

RECOMMENDED OPERATING CONDITIONS

VDD Voltage	1.65V to 6.5V
SENSE1, SENSE2 Voltage	0V to 6.5V
OUT1, OUT2 Voltage	0V to 6.5V
OUT1, OUT2 Current	±5mA
Pull-up Resistor, R_{PU}	1.5kΩ to 10MΩ
Input Capacitor, C_{IN}	0.1μF
Operating Junction Temperature Range	-40°C to +125°C

OVERSTRESS CAUTION

Stresses beyond those listed in Absolute Maximum Ratings may cause permanent damage to the device. Exposure to absolute maximum rating conditions for extended periods may affect reliability. Functional operation of the device at any conditions beyond those indicated in the Recommended Operating Conditions section is not implied.

ESD SENSITIVITY CAUTION

This integrated circuit can be damaged if ESD protections are not considered carefully. SGMICRO recommends that all integrated circuits be handled with appropriate precautions. Failure to observe proper handling and installation procedures can cause damage. ESD damage can range from subtle performance degradation to complete device failure. Precision integrated circuits may be more susceptible to damage because even small parametric changes could cause the device not to meet the published specifications.

DISCLAIMER

SG Micro Corp reserves the right to make any change in circuit design, or specifications without prior notice.

PIN CONFIGURATIONS

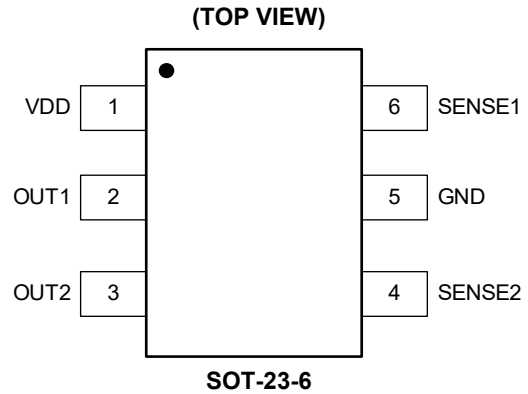
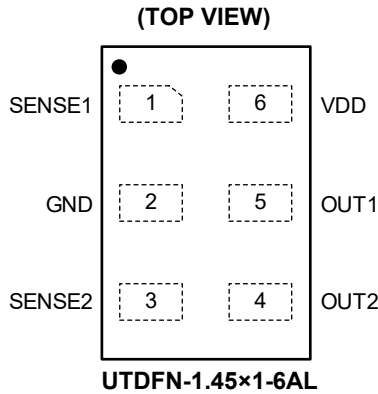

PIN DESCRIPTION

PIN		NAME	FUNCTION
UTDFN-1.45x1-6AL	SOT-23-6		
1	6	SENSE1	Voltage Monitor Input 1. This pin is the input of external resistor divider.
2	5	GND	Ground.
3	4	SENSE2	Voltage Monitor Input 2. This pin is the input of external resistor divider.
4	3	OUT2	Voltage Monitor Output 2 for SENSE 2. It is an open-drain output that can be pulled up to 6.5V independently of V _{DD} through a pull-up resistor. When the input voltage of SENSE2 falls below the falling threshold V _{IT-} , OUT2 is driven low. When the input voltage of SENSE2 exceeds the rising threshold V _{IT+} , OUT2 goes high.
5	2	OUT1	Voltage Monitor Output 1 for SENSE 1. It is an open-drain output that can be pulled up to 6.5V independently of V _{DD} through a pull-up resistor. When the input voltage of SENSE1 falls below the falling threshold V _{IT-} , OUT1 is driven low. When the input voltage of SENSE1 exceeds the rising threshold V _{IT+} , OUT1 goes high.
6	1	VDD	Power Supply input. Connect VDD to a 1.65V to 6.5V supply. A 0.1μF ceramic capacitor near this pin is recommended.

ELECTRICAL CHARACTERISTICS(V_{DD} = 1.65V to 6.5V, T_J = -40°C to +125°C, typical values are at V_{DD} = 3.3V and T_J = +25°C, unless otherwise noted.)

Parameter	SYMBOL	CONDITIONS	MIN	TYP	MAX	UNITS	
Input Supply Range	V _{DD}		1.65		6.5	V	
Power-on Reset Voltage ⁽¹⁾	V _{POR}	V _{OL_MAX} = 0.2V, I _{OL} = 15μA			0.8	V	
Supply Current (Into VDD Pin)	I _{DD}	V _{DD} = 3.3V, no load		1.1	3.0	μA	
		V _{DD} = 6.5V, no load		1.8	4.5		
Positive-Going Input Threshold Voltage	V _{IT+}	V _{SENSE} rising		1.182		V	
			V _{DD} = 1.65V to 3.3V	-1.5		1.5	%
			V _{DD} = 1.65V to 6.5V	-1.7		1.7	%
Negative-Going Input Threshold Voltage	V _{IT-}	V _{SENSE} falling	SGM862A (0.6% hysteresis)	1.175		V	
			SGM862B (1% hysteresis)	1.169			
			SGM862C (5% hysteresis)	1.121			
			SGM862D (10% hysteresis)	1.062			
			V _{DD} = 1.65V to 3.3V	-1.5		1.5	%
			V _{DD} = 1.65V to 6.5V	-1.7		1.7	%
Input Current	I _{SENSE}	V _{SENSE} = 0V or V _{DD}		0.2	50	nA	
Low-Level Output Voltage	V _{OL}	V _{DD} ≥ 1.3V, I _{SINK} = 0.4mA			0.25	V	
		V _{DD} ≥ 1.65V, I _{SINK} = 0.4mA			0.25		
		V _{DD} ≥ 2.7V, I _{SINK} = 2mA			0.25		
		V _{DD} ≥ 4.5V, I _{SINK} = 3.2mA			0.3		
Open-Drain Output Leakage Current	I _{LKG_OD}	High impedance, V _{SENSE} = V _{OUT} = 6.5V	-70		70	nA	

NOTE:

1. Outputs are undetermined below V_{POR}.

TIMING REQUIRMENTS

(SENSE_x transitions between 0V and 1.3V, R_{PU1} = R_{PU2} = 10kΩ, typical values are at V_{DD} = 3.3V and T_J = +25°C, unless otherwise noted.)

PARAMETER	SYMBOL	CONDITIONS	MIN	TYP	MAX	UNITS
SENSE _x (Rising) to OUT Propagation Delay	t _{PD_R}			14		μs
SENSE _x (Falling) to OUT Propagation Delay	t _{PD_F}			12		μs
Startup Delay ⁽¹⁾	t _{SD}			730		μs

NOTE:

1. During power-on or a period that V_{DD} transient is lower than V_{DD_MIN}, the outputs reflect the input conditions 730μs after V_{DD} transitions through V_{DD_MIN}.

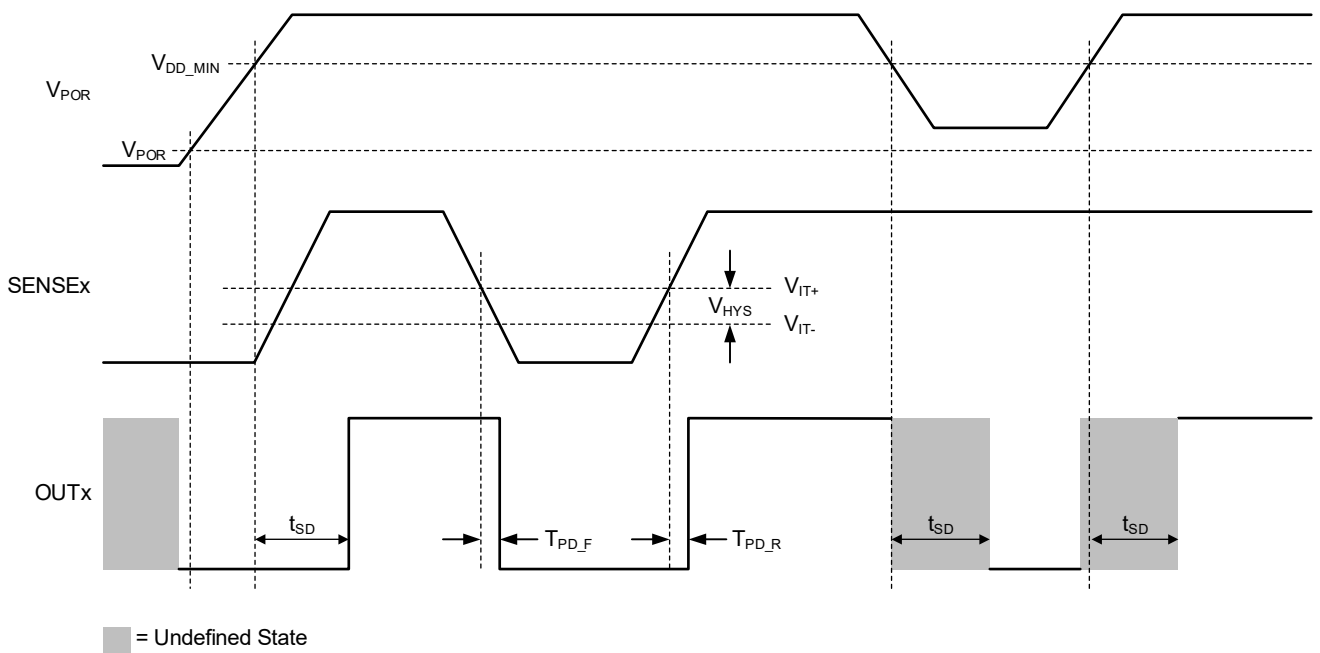
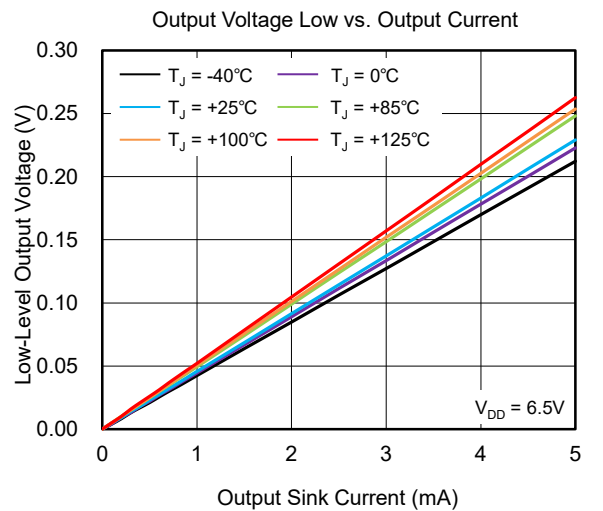
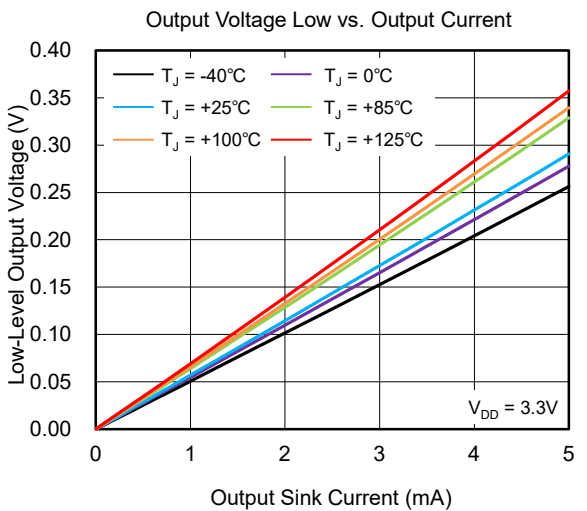
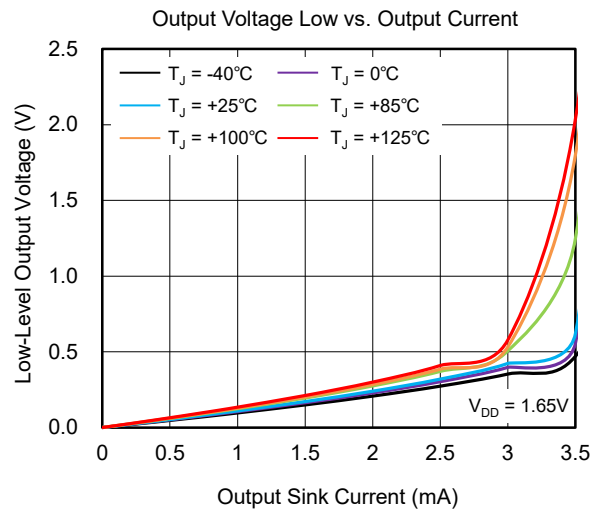
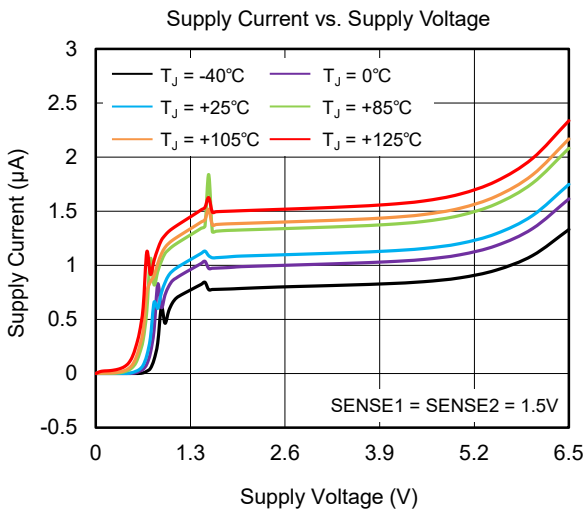
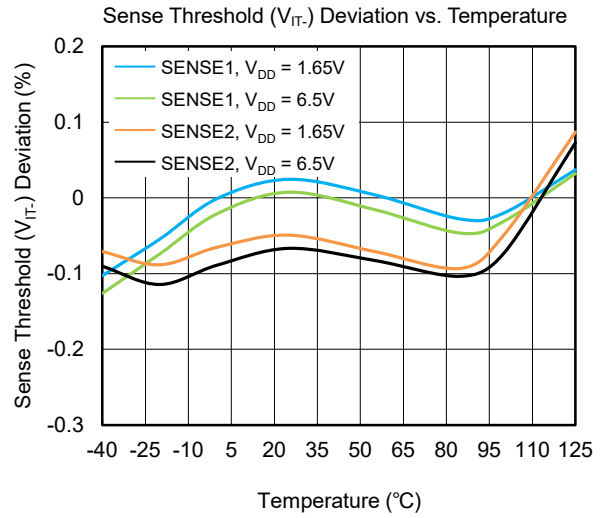
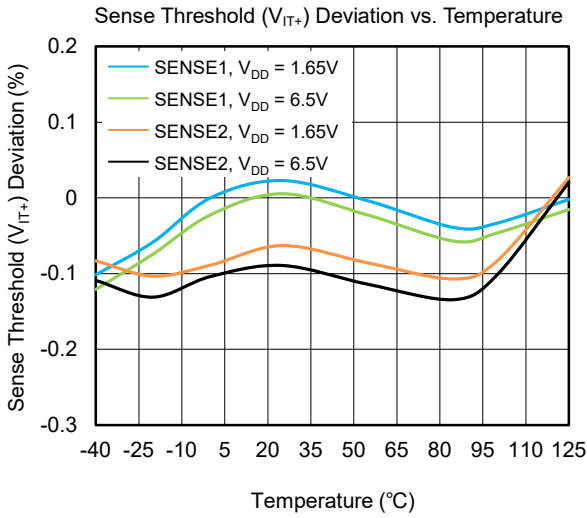

Figure 2. Timing Diagram

TYPICAL PERFORMANCE CHARACTERISTICS

T_J = +25°C with a 0.1µF capacitor beside VDD, unless otherwise noted.



TYPICAL PERFORMANCE CHARACTERISTICS (continued)

T_J = +25°C with a 0.1µF capacitor beside VDD, unless otherwise noted.

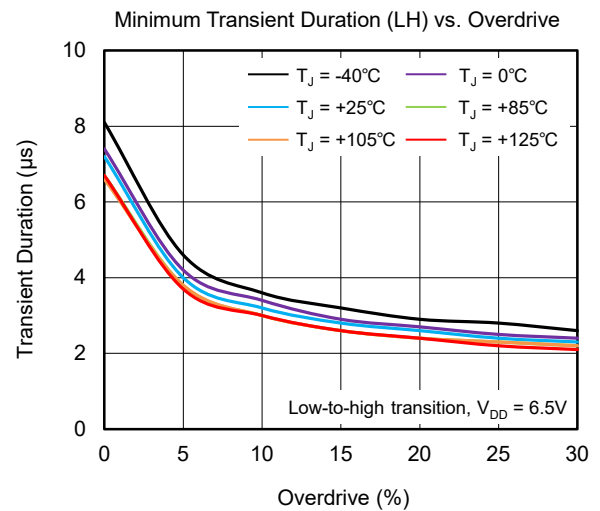
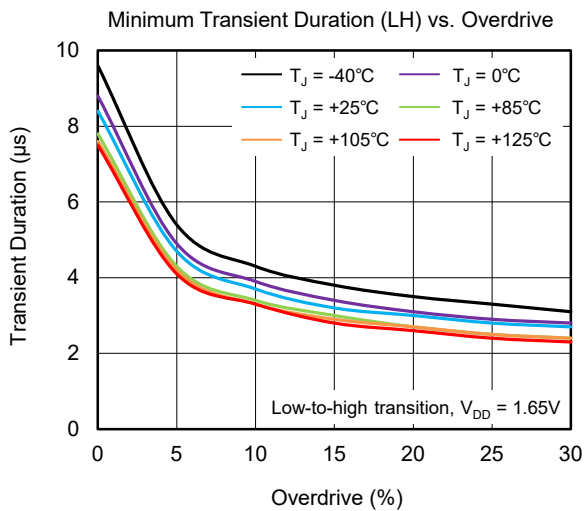
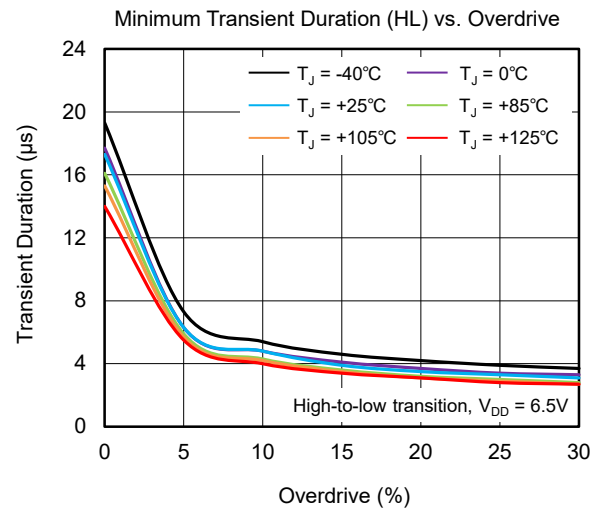
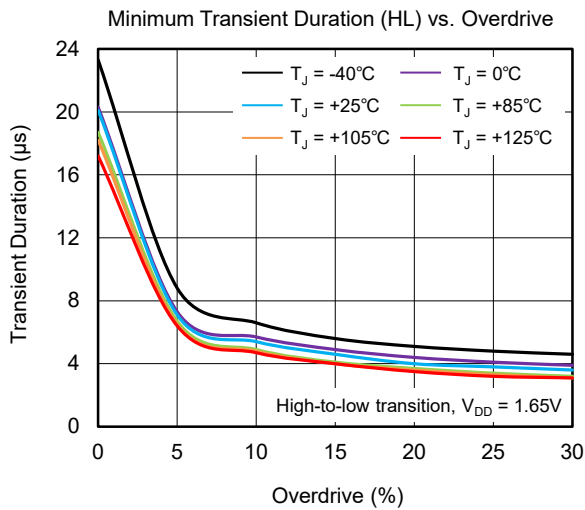
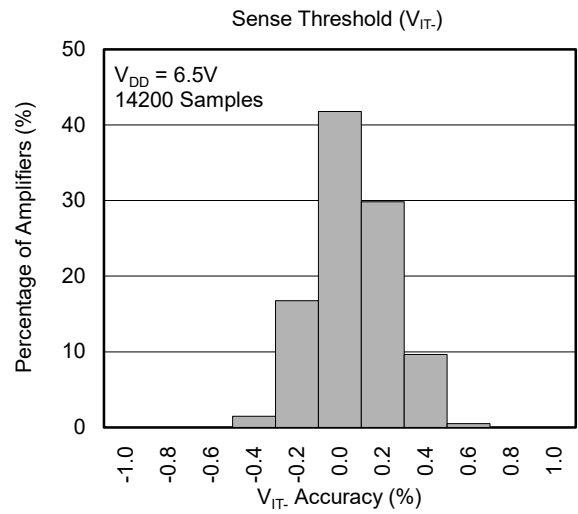
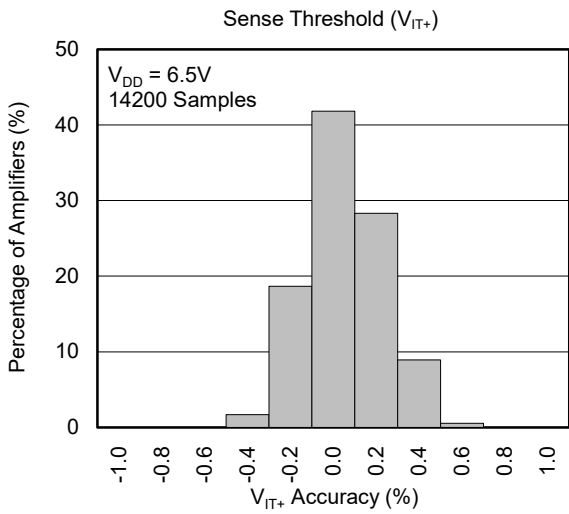

TYPICAL PERFORMANCE CHARACTERISTICS (continued)

T_J = +25°C with a 0.1µF capacitor beside VDD, unless otherwise noted.

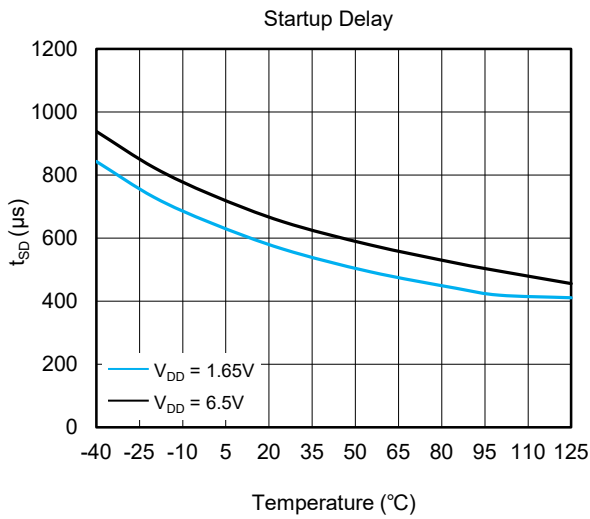
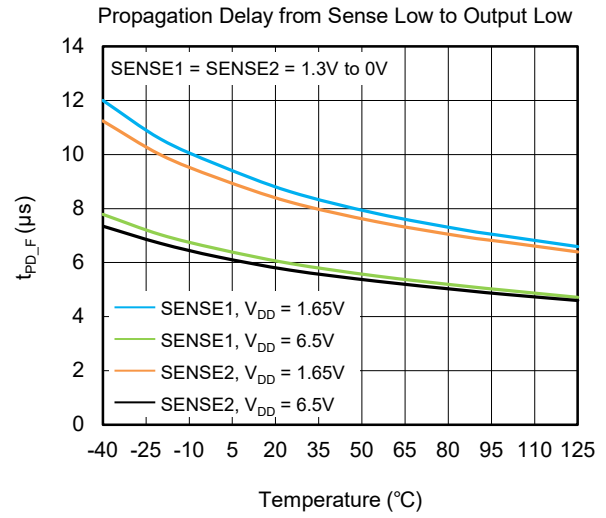
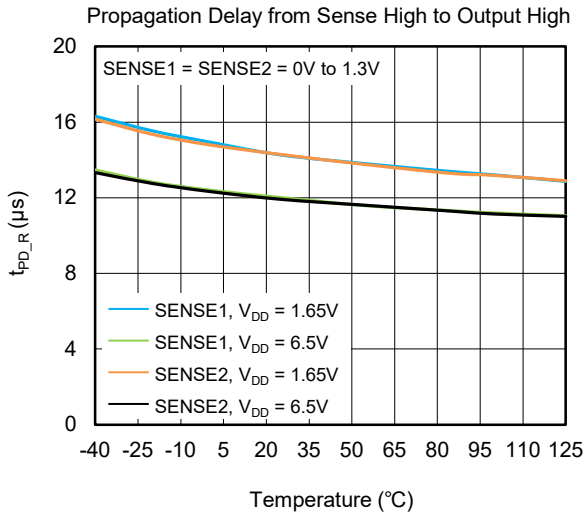

FUNCTIONAL BLOCK DIAGRAM

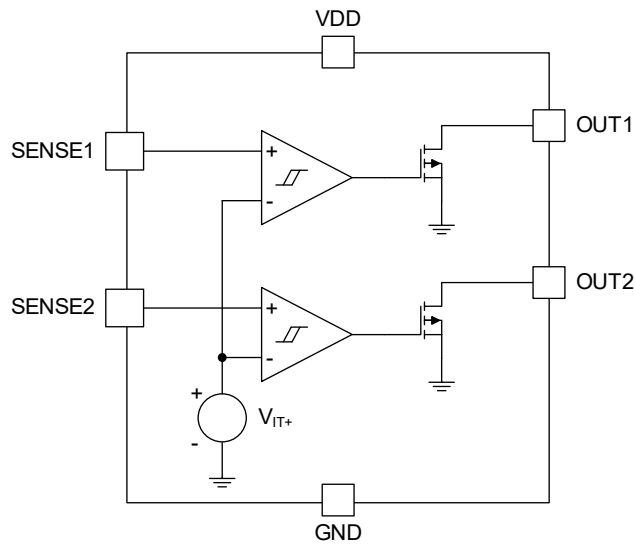

Figure 3. SGM862 Block Diagram

DETAILED DESCRIPTION

Overview

The SGM862 family is a high-accuracy, low-power, and small size dual-channel voltage detector with open-drain output.

SENSE_x is the input pin which can be programmed with an external resistor divider. There are four different hysteresis options of 0.6%, 1%, 5% or 10%. As shown in Table 1, OUT_x goes low when the input voltage of SENSE_x is lower than the falling threshold (V_{IT-}). OUT_x goes high when the input voltage of SENSE_x is higher than the rising threshold (V_{IT+}). The internal hysteresis of SENSE_x has glitch immunity and ensures stable operation.

The device can be used to monitor multiple voltage rails in applications or simultaneously monitor both early warning signal channel and reset signal channel in one system.

Table 1. SGM862 Truth Table

Conditions	Output
SENSE1 < V_{IT-}	OUT1 = low
SENSE2 < V_{IT-}	OUT2 = low
SENSE1 > V_{IT+}	OUT1 = high
SENSE2 > V_{IT+}	OUT2 = high

Inputs (SENSE1, SENSE2)

The SGM862 has two voltage detection comparators. The comparator input voltage is from 0V to 6.5V, which is independent of the device power supply voltage used. The non-inverting input of the comparator is connected to the external resistor divider. The inverting input of the comparator is connected to an internal threshold reference. When SENSE_x voltage drops below V_{IT-} , the corresponding OUT_x is driven low. When SENSE_x voltage rises above V_{IT+} , the corresponding OUT_x is driven high. The hysteresis falling threshold prevents the comparator from being falsely triggered, and ensures stable operation.

In situations with extremely high noise and interference, it is recommended to place a 1nF to 10nF bypass capacitor at the input of the comparator to improve transient immunity and reduce the sensitivity of layout parasitism. In most cases, the decoupling capacitance is not required. See Figure 2 for more details.

Outputs (OUT1, OUT2)

The SGM862 is usually used in reset or power sequencing circuit, where the output is connected to the digital signal processor (DSP), microcontroller (μ C), microprocessor (CPU) and so on, or the output is connected to the DC/DC or LDO enable terminal to enable or disable the power converter.

OUT1 and OUT2 are two open-drain outputs of SGM862. A pull-up resistor is needed to connect a voltage rail, which can be up to 6.5V and is independent of the device power supply voltage (V_{DD}). To choose a proper pull-up resistor, users should consider low-level output voltage (V_{OL}), sink current capability and output leakage current (I_{LKG_OD}). The open-drain output is convenient for the logic level compatibility. Another advantage of open-drain output is to implement wired and logic easily. OUT1 and OUT2 can be combined into one logic signal. The input (SENSE1, SENSE2) section has described how to assert or deassert the output.

Device Functional Modes

Normal Operation ($V_{DD} \geq V_{DD_MIN}$)

Once the voltage on VDD rises above V_{DD_MIN} and lasts for t_{SD} , the OUT_x starts to indicate the present state of corresponding SENSE_x pins.

Power-On Reset ($V_{DD} < V_{POR}$)

Once the voltage on VDD is below V_{POR} which is the required voltage to pull the output to GND, the OUT_x is undefined and unreliable for proper system operation.

APPLICATION INFORMATION

The SGM862 family is a dual-voltage detector with high accuracy. The monitored voltage, VDD voltage and output pull-up voltage can be flexibly used as independent voltages or connected to any other configuration.

Threshold Overdrive

Threshold overdrive is how much SENSEx exceeds the threshold V_{IT} , which is important to know because the larger the overdrive is, the faster the OUTX responses. V_{IT} is the threshold voltage in Equation 1. Use the percent of the sense voltage threshold to calculate the threshold overdrive.

$$\text{Overdrive} = | (V_{\text{SENSE}}/V_{IT} - 1) \times 100\% | \quad (1)$$

V_{IT} is V_{IT-} when calculating the negative-going threshold overdrive. V_{IT} is V_{IT+} when calculating the positive-going threshold overdrive.

Sense Resistor Divider

Use Equation 2 to calculate the resistor divider values, which determines $V_{\text{MON_UV}}$. Use Equation 3 to calculate the target threshold voltage, which determines $V_{\text{MON_PG}}$.

$$V_{\text{MON_UV}} = \left(1 + \frac{R_1}{R_2} \right) \times V_{IT-} \quad (2)$$

$$V_{\text{MON_PG}} = \left(1 + \frac{R_1}{R_2} \right) \times V_{IT+} \quad (3)$$

SENSEx pins:

R_1 is the upper divider resistor. R_2 is the lower divider resistor.

$V_{\text{MON_UV}}$ is the target voltage for monitoring the under-voltage.

$V_{\text{MON_PG}}$ is the target voltage that monitors the output goes high during V_{MONx} rises.

Selecting the total resistance values of R_1 and R_2 determines that the current flowing through the divider about 100 times higher than the SENSEx input current. Meanwhile, choose the resistors values as high as possible to minimize current consumption which will not bring about obvious error to the resistance divider.

Power-Supply Recommendations

The input supply voltage of SGM862 ranges from 1.65V to 6.5V. A 0.1 μ F or greater ceramic capacitor close to VDD pin is recommended. VDD pin has a 7V absolute maximum rating.

APPLICATION INFORMATION (Continued)

Monitoring Two Separate Rails

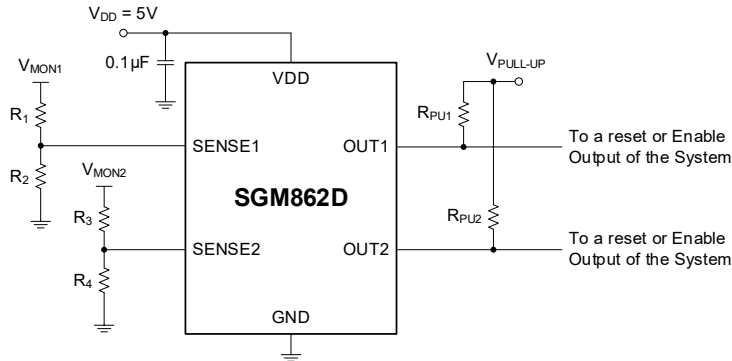

Figure 4. Monitoring Two Separate Rails Circuit

Table 2. Design Parameters

Parameter	Design Requirement	Design Result
V _{DD}	5V	5V
Hysteresis	10%	10%
Monitored Voltage 1	3.3V Nominal, V _{MON_PG} = 2.9V, V _{MON_LUV} = 2.6V	V _{MON_PG} = 2.905V, V _{MON_LUV} = 2.610V
Monitored Voltage 2	3.3V Nominal, V _{MON_PG} = 2.6V, V _{MON_LUV} = 2.35V	V _{MON_PG} = 2.604V, V _{MON_LUV} = 2.340V
Output Logic Voltage	3.3V CMOS	3.3V CMOS

Detailed Design Procedure

The SGM862D is 10% hysteresis version and chosen finally. An open-drain output allows for the output to be pulled up to a voltage other than V_{DD}.

Use Equation 2 and Equation 3 to calculate the resistor divider values. For SENSE1, R₁ = 1.72MΩ and R₂ = 1.18MΩ. While R₃ and R₄ of SENSE2 can be calculate through R₁ and R₂ in Equation 2 and Equation 3. Therefore, R₃ = 1.42MΩ and R₄ = 1.18MΩ.

Application Curve

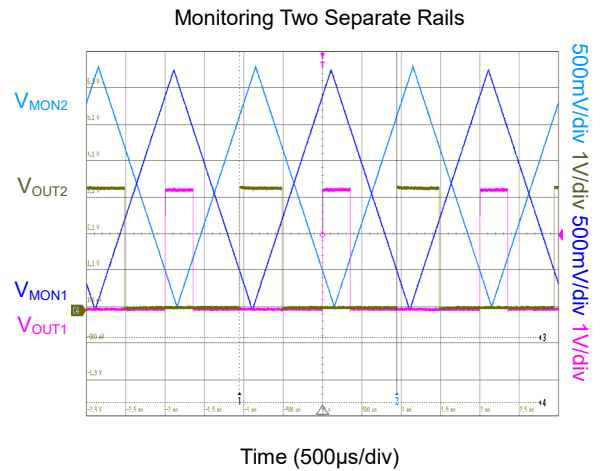

APPLICATION INFORMATION (Continued)

Early Warning Detection

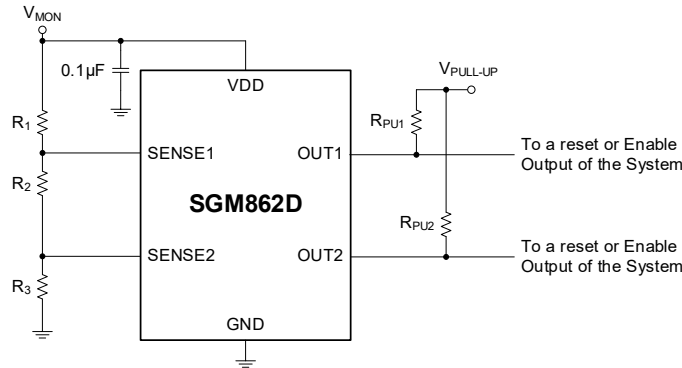

Figure 5. Early Warning Detection Schematic

Table 3. Design Parameters

Parameter	Design Requirement	Design Result
V _{DD}	V _{MON}	V _{MON}
Hysteresis	10%	10%
Monitored voltage 1	V _{MON_PG} = 3.3V, V _{MON_UV} = 3V	V _{MON_PG} = 3.389V, V _{MON_UV} = 3.050V
Monitored voltage 2	V _{MON_PG} = 3.9V, V _{MON_UV} = 3.5V	V _{MON_PG} = 3.937V, V _{MON_UV} = 3.543V

Detailed Design Procedure

The SGM862D is 10% hysteresis version and chosen finally.

Use Equation 4 to calculate the total resistor divider values. The minimum total resistance of the resistor network is calculated based on the current consumption specification. Choose the current approximately 1µA that flows through the resistor network. In this case, from low to high conversion, V_{MON_PG2} is considered more important.

$$R_{TOTAL} = \frac{V_{MON_PG_2}}{I} = \frac{3.9V}{1\mu A} = 3.9M\Omega \quad (4)$$

Use Equation 5 to calculate R₃. V_{MON_PG2} corresponds to V_{IT+} value in channel 2. Select the nearest 1% accuracy resistor value instead of the calculated. In this case, 1.18MΩ is the closest value for R₃.

$$R_3 = \frac{V_{IT+}}{I} = \frac{1.182V}{1\mu A} = 1.182M\Omega \quad (5)$$

Use Equation 6 to calculate R₂. Select the nearest 1% accuracy resistor value instead of the calculated. In this case, 200kΩ is the closest value for R₂. In this case, from high-to-low conversion, V_{MON_UV_1} is considered more important.

$$R_2 = \frac{R_{TOTAL}}{V_{MON_UV_1}} \times V_{IT-} - R_3 = \frac{3.9M\Omega}{3V} \times 1.061V - 1.18M\Omega = 199k\Omega \quad (6)$$

Use Equation 7 to calculate R₁. Select the nearest 1% accuracy resistor value instead of the calculated. In this case, 2.55MΩ is the closest value for R₁.

$$R_1 = R_{TOTAL} - R_2 - R_3 = 3.9M\Omega - 200k\Omega - 1.18M\Omega = 2.52M\Omega \quad (7)$$

Application Curve

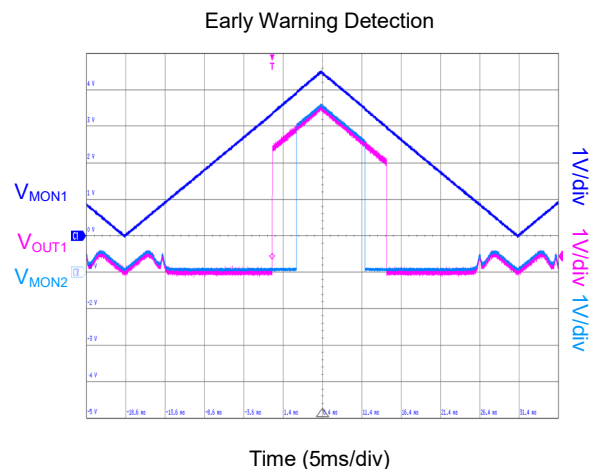

LAYOUT

It is recommended to place the decoupling capacitor close to VDD, and place the bypass capacitor close to the SENSEx if the bypass capacitor is necessary.

Avoid long traces to power VDD. The VDD decoupling capacitor and parasitic inductance from long traces can form LC resonance and cause ringing with peak voltages, which may damage the device.

REVISION HISTORY

NOTE: Page numbers for previous revisions may differ from page numbers in the current version.

Changes from Original (JUNE 2023) to REV.A	Page
Changed from product preview to production data.....	All

PACKAGE OUTLINE DIMENSIONS

UTDFN-1.45×1-6AL

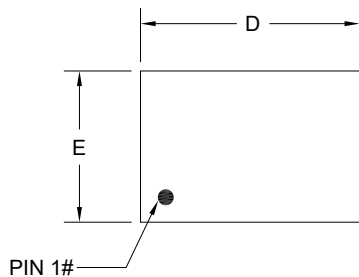

TOP VIEW

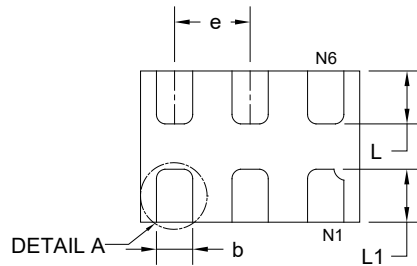

BOTTOM VIEW

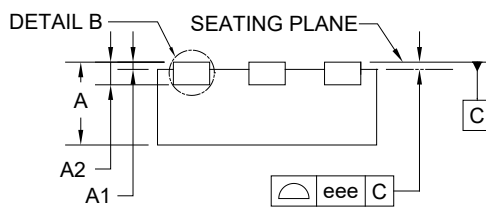

SIDE VIEW

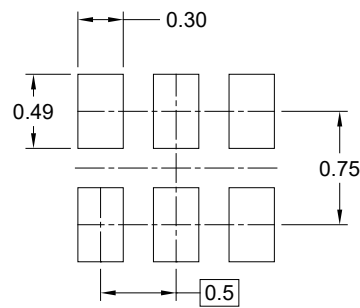

RECOMMENDED LAND PATTERN (Unit: mm)

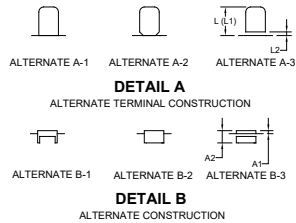

Symbol	Dimensions In Millimeters		
	MIN	MOD	MAX
A	0.450	-	0.600
A1	-0.004	-	0.050
A2	0.150 REF		
b	0.150	-	0.300
D	1.374	-	1.526
E	0.924	-	1.076
e	0.500 BSC		
L	0.250	-	0.450
L1	0.250	-	0.500
L2	0.000	-	0.100
eee	0.050		

NOTE: This drawing is subject to change without notice.

PACKAGE OUTLINE DIMENSIONS

SOT-23-6

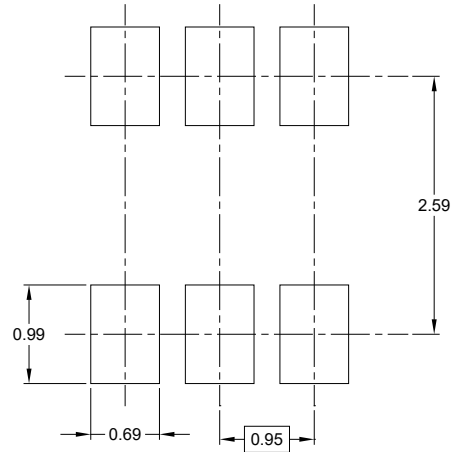
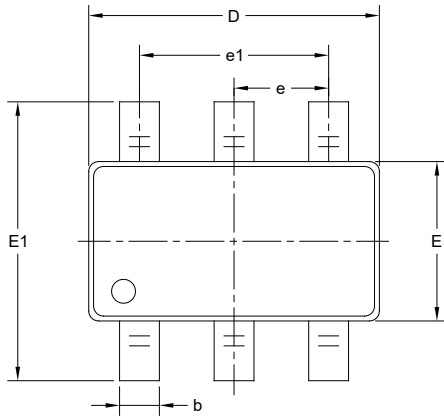

RECOMMENDED LAND PATTERN (Unit: mm)

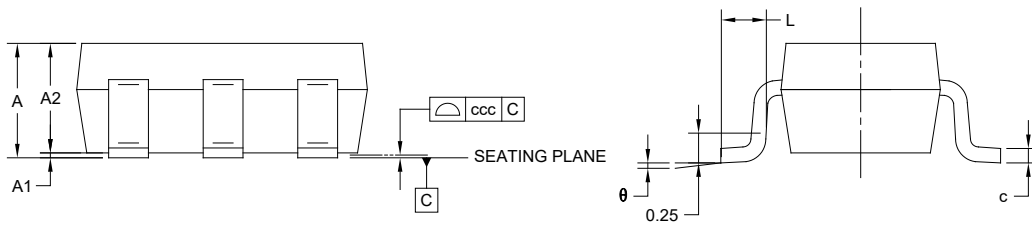

Symbol	Dimensions In Millimeters		
	MIN	MOD	MAX
A	-	-	1.450
A1	0.000	-	0.150
A2	0.900	-	1.300
b	0.300	-	0.500
c	0.080	-	0.220
D	2.750	-	3.050
E	1.450	-	1.750
E1	2.600	-	3.000
e	0.950 BSC		
e1	1.900 BSC		
L	0.300	-	0.600
θ	0°	-	8°
ccc	0.100		

NOTES:

1. This drawing is subject to change without notice.
2. The dimensions do not include mold flashes, protrusions or gate burrs.
3. Reference JEDEC MO-178.

TAPE AND REEL INFORMATION

REEL DIMENSIONS



TAPE DIMENSIONS



NOTE: The picture is only for reference. Please make the object as the standard.

KEY PARAMETER LIST OF TAPE AND REEL

Package Type	Reel Diameter	Reel Width W1 (mm)	A0 (mm)	B0 (mm)	K0 (mm)	P0 (mm)	P1 (mm)	P2 (mm)	W (mm)	Pin1 Quadrant
UTDFN-1.45×1-6AL	7"	9.5	1.15	1.60	0.75	4.0	4.0	2.0	8.0	Q1
SOT-23-6	7"	9.5	3.23	3.17	1.37	4.0	4.0	2.0	8.0	Q3

D00001

PACKAGE INFORMATION

CARTON BOX DIMENSIONS



NOTE: The picture is only for reference. Please make the object as the standard.

KEY PARAMETER LIST OF CARTON BOX

Reel Type	Length (mm)	Width (mm)	Height (mm)	Pizza/Carton
7" (Option)	368	227	224	8
7"	442	410	224	18

DD0002