

GENERAL DESCRIPTION

The SGM41295 provides DC bias for the laser diode, EA bias, and MPD bias monitor circuits, and it also provides an unregulated negative output generated by an inverting charge pump which is equal to negative input voltage.

The SGM41295 is available in a Green TQFN-3x3-16L package. It operates over an ambient temperature range of -40°C to +105°C.

APPLICATIONS

EML Fiber Modules
 AOC and Transponders for Telecom and Data Center Interconnection

FEATURES

- **Negative Charge Pump Output (-1x) with 150mA Maximum Loading Current**
- **Digitally Programmable EAM Bias and LD Driving Current Source**
- **Voltage Sources for EAM Bias (-0.2V to -3.2V, 12.5mV/Step) with 100mA Maximum Loading Current**
- **Current Sources for LD (0mA to 239.5mA, 0.5mA/Step or 0mA to 119.75mA, 0.25mA/Step)**
- **Backside MPD Current Monitoring (0mA to 3mA)**
- **Support I²C Interface and up to 1MHz I²C Clock Frequency**
- **No Inrush Current during Startup**
- **Charge Pump Output Short Protection**
- **LD Short/Open and EAM Short Monitoring**
- **+135°C Over-Temperature Alert Bit**
- **+155°C Over-Temperature Shutdown**
- **Available in a Green TQFN-3x3-16L Package**

TYPICAL APPLICATION

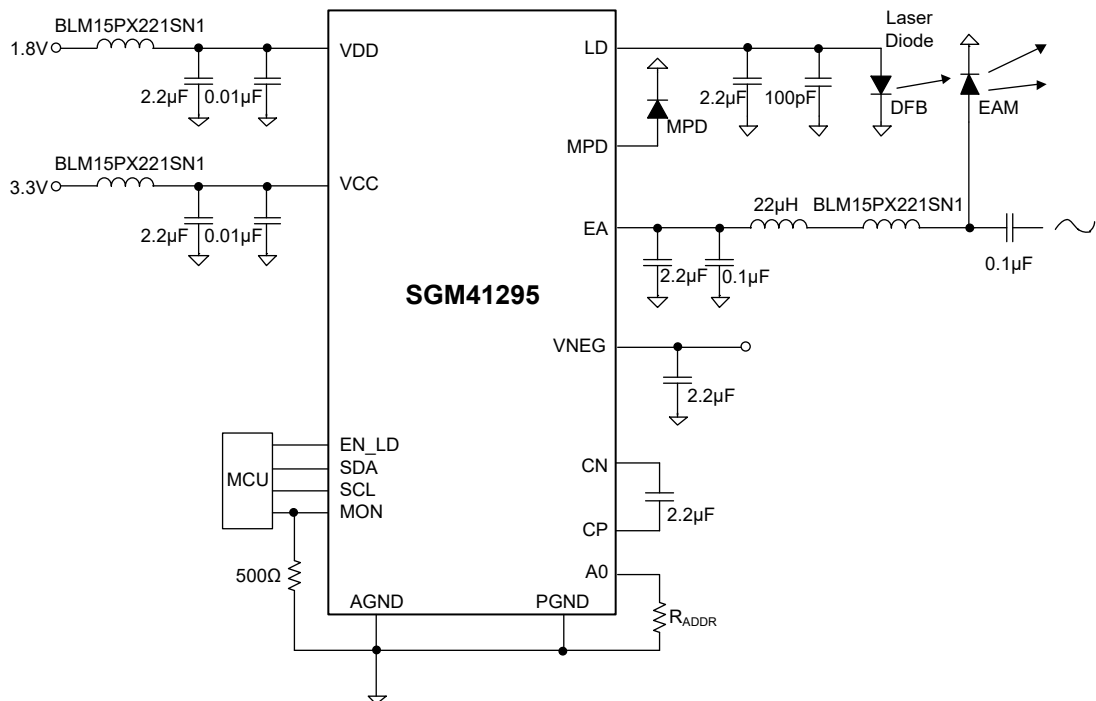

Figure 1. Typical Application Circuit

PACKAGE/ORDERING INFORMATION

MODEL	PACKAGE DESCRIPTION	SPECIFIED TEMPERATURE RANGE	ORDERING NUMBER	PACKAGE MARKING	PACKING OPTION
SGM41295	TQFN-3x3-16L	-40°C to +105°C	SGM41295GTQ16G/TR	CB2TQ XXXXXX	Tape and Reel, 4000

MARKING INFORMATION

NOTE: XXXXX = Date Code, Trace Code and Vendor Code.

XXXXX

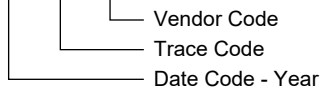

Green (RoHS & HSF): SG Micro Corp defines "Green" to mean Pb-Free (RoHS compatible) and free of halogen substances. If you have additional comments or questions, please contact your SGMICRO representative directly.

ABSOLUTE MAXIMUM RATINGS

- V_{CC}, V_{DD}, SDA, SCL..... -0.3V to 6V
- V_{NEG}..... -6V to 0.3V
- MON, V_{CP}, EN_LD, A0..... -0.3V to V_{CC} + 0.3V
- MPD, V_{EA}, V_{CN}..... V_{NEG} - 0.3V to 0.3V
- LD..... -0.3V to V_{DD} + 0.3V
- Typical Thermal Resistance
- TQFN-3x3-16L, θ_{JA}..... 50°C/W
- Junction Temperature..... +150°C
- Storage Temperature Range..... -65°C to +150°C
- Lead Temperature (Soldering, 10s)..... +260°C
- ESD Susceptibility
- HBM..... 2000V
- CDM..... 1000V

RECOMMENDED OPERATING CONDITIONS

- V_{CC}..... 2.85V to 5.5V
- V_{DD}..... 1.5V to 5.5V
- MON Current Output Range..... 0mA to 3mA
- MON Voltage Output Range..... 0V to 3.3V
- SCL, SDA Pull-Up Voltage..... 2.5V (MIN)
- Operating Junction Temperature Range..... -40°C to +125°C
- Operating Ambient Temperature Range..... -40°C to +105°C

OVERSTRESS CAUTION

Stresses beyond those listed in Absolute Maximum Ratings may cause permanent damage to the device. Exposure to absolute maximum rating conditions for extended periods may affect reliability. Functional operation of the device at any conditions beyond those indicated in the Recommended Operating Conditions section is not implied.

ESD SENSITIVITY CAUTION

This integrated circuit can be damaged if ESD protections are not considered carefully. SGMICRO recommends that all integrated circuits be handled with appropriate precautions. Failure to observe proper handling and installation procedures can cause damage. ESD damage can range from subtle performance degradation to complete device failure. Precision integrated circuits may be more susceptible to damage because even small parametric changes could cause the device not to meet the published specifications.

DISCLAIMER

SG Micro Corp reserves the right to make any change in circuit design, or specifications without prior notice.

PIN CONFIGURATION

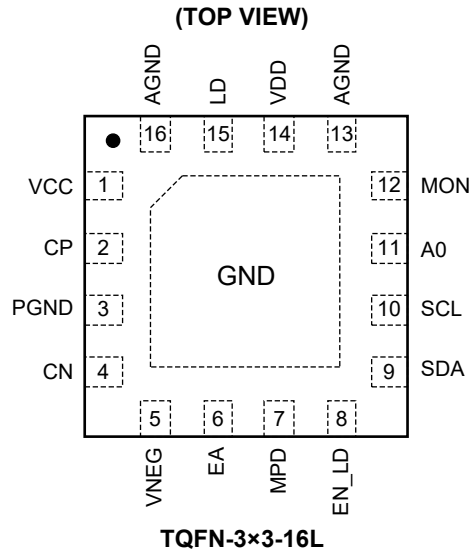

PIN DESCRIPTION

PIN	NAME	TYPE	FUNCTION
1	VCC	P	Power Supply for the Chip.
2	CP	I/O	Fly Capacitor Positive Connection.
3	PGND	G	Power Ground.
4	CN	I/O	Fly Capacitor Negative Connection.
5	VNEG	O	Charge Pump Output.
6	EA	O	EAM Biasing Output. The output voltage of EA is programmable via the I ² C interface.
7	MPD	I	MPD Current Monitor Input. Cathode of MPD is connected to ground and anode of MPD is connected to this pin.
8	EN_LD	I	Laser Bias Enable. Logic low disables the laser bias only (not EAM bias). Logic high enables the laser bias. Don't leave it floating.
9	SDA	IO	Data for the I ² C Compatible Interface.
10	SCL	IO	Clock for the I ² C Compatible Interface.
11	A0	O	Slave Address Programming. To program the address, a resistor is connected between this pin and ground.
12	MON	O	Multiplexed Monitor Output. There are three monitor signals selected via I ² C interface.
13, 16	AGND	G	Analog Ground.
14	VDD	P	Power Supply for Laser Diode Current Source.
15	LD	O	Laser Biasing Output. The current of LD is programmable via the I ² C interface.
-	Exposed Pad	G	Exposed Pad. Used for circuit ground connection.

NOTE: I: input, O: output, I/O: input or output, G: ground, P: power for the circuit.

PACKAGE INFORMATION

PACKAGE OUTLINE DIMENSIONS

TQFN-3x3-16L

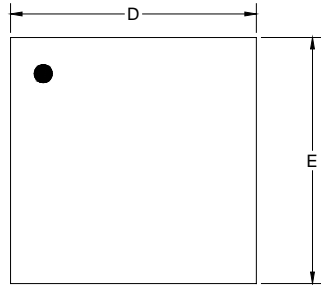

TOP VIEW

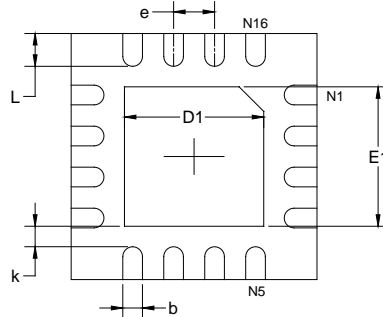

BOTTOM VIEW

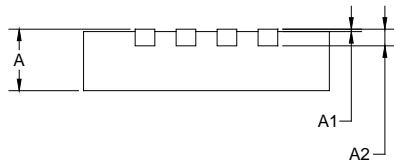

SIDE VIEW

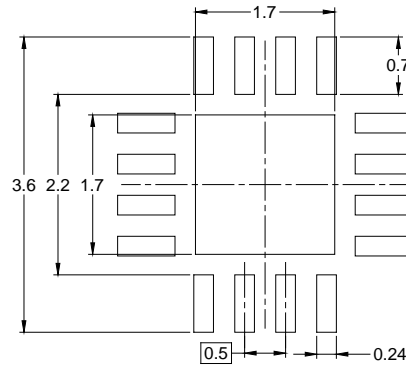

RECOMMENDED LAND PATTERN (Unit: mm)

Symbol	Dimensions In Millimeters		Dimensions In Inches	
	MIN	MAX	MIN	MAX
A	0.700	0.800	0.028	0.031
A1	0.000	0.050	0.000	0.002
A2	0.203 REF		0.008 REF	
D	2.900	3.100	0.114	0.122
D1	1.600	1.800	0.063	0.071
E	2.900	3.100	0.114	0.122
E1	1.600	1.800	0.063	0.071
k	0.200 MIN		0.008 MIN	
b	0.180	0.300	0.007	0.012
e	0.500 TYP		0.020 TYP	
L	0.300	0.500	0.012	0.020

NOTE: This drawing is subject to change without notice.

PACKAGE INFORMATION

TAPE AND REEL INFORMATION

REEL DIMENSIONS



TAPE DIMENSIONS



NOTE: The picture is only for reference. Please make the object as the standard.

KEY PARAMETER LIST OF TAPE AND REEL

Package Type	Reel Diameter	Reel Width W1 (mm)	A0 (mm)	B0 (mm)	K0 (mm)	P0 (mm)	P1 (mm)	P2 (mm)	W (mm)	Pin1 Quadrant
TQFN-3×3-16L	13"	12.4	3.35	3.35	1.13	4.0	8.0	2.0	12.0	Q2

000001

PACKAGE INFORMATION

CARTON BOX DIMENSIONS



NOTE: The picture is only for reference. Please make the object as the standard.

KEY PARAMETER LIST OF CARTON BOX

Reel Type	Length (mm)	Width (mm)	Height (mm)	Pizza/Carton
13"	386	280	370	5

DD0002