

### GENERAL DESCRIPTION

The SGM819SxQ is an independent watchdog timer circuit. It can be used to guard against system failures due to hardware types like peripherals errors and bus occupancy or software types like infinite code execution in a loop.

This device has a WDI input and an nWDO output. In normal conditions, the WDI is toggled within the preset timeout period called  $t_{WD}$  in order to clear the watchdog timer. However, if an error event occurs and the watchdog timer is not reset within  $t_{WD}$ , the nWDO is asserted to send out the alarm signal.

The SGM819SxQ has an enable pin (nEN) to control the device to turn on/off the watchdog function. To turn on the watchdog function, just connect nEN pin which has a built-in pull-down resistor to GND or leave it floating.

The device is AEC-Q100 qualified (Automotive Electronics Council (AEC) standard Q100 Grade 1) and it is suitable for automotive applications.

The SGM819SxQ is available in a Green SOT-23-5 package. It operates over the junction temperature range of  $-40^{\circ}\text{C}$  to  $+125^{\circ}\text{C}$ .

### DEVICE DESCRIPTION

Model: SGM819S-mQ/SGM819S-mnQ						
Watchdog Timeout Period Options						
Option Code: "m"	A	B	C	D	E	F
Watchdog Timeout Period	3.4ms	6.8ms	108.8ms	1.7s	7.0s	27.9s
Watchdog Active Time Options						
Option Code: "n"	A		B			
Watchdog Active Time	27.2ms		217.6ms			

### FEATURES

- AEC-Q100 Qualified for Automotive Applications Device Temperature Grade 1  
 $T_A = -40^{\circ}\text{C}$  to  $+125^{\circ}\text{C}$
- Current Consumption: 3.5 $\mu\text{A}$  (TYP)
- Six Selectable Watchdog Timeout Periods: 3.4ms, 6.8ms, 108.8ms, 1.7s, 7.0s and 27.9s
- Two Selectable Watchdog Active Time: 27.2ms and 217.6ms
- Watchdog Timer Accuracy:  $\pm 20\%$
- Active-Low Enable Input
- Open-Drain nWDO Output
- Available in a Green SOT-23-5 Package

### APPLICATIONS

- Automotive Applications
- Industrial Equipment
- Telecommunications
- Safety Applications
- Networking
- Medical Equipment
- UPS System

### TYPICAL APPLICATION

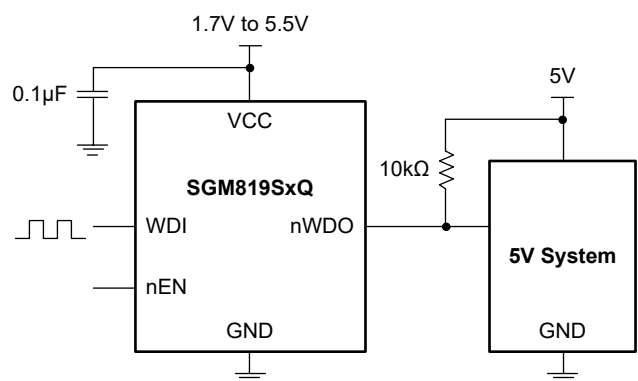

Figure 1. Typical Application Circuit

**PACKAGE/ORDERING INFORMATION**

MODEL	PACKAGE DESCRIPTION	SPECIFIED TEMPERATURE RANGE	ORDERING NUMBER	PACKAGE MARKING	PACKING OPTION
SGM819S-AQ	SOT-23-5	-40°C to +125°C	SGM819S-AQN5G/TR	0MY XXXXX	Tape and Reel, 3000
SGM819S-BAQ	SOT-23-5	-40°C to +125°C	SGM819S-BAQN5G/TR	0T5 XXXXX	Tape and Reel, 3000
SGM819S-BBQ	SOT-23-5	-40°C to +125°C	SGM819S-BBQN5G/TR	0T6 XXXXX	Tape and Reel, 3000
SGM819S-CAQ	SOT-23-5	-40°C to +125°C	SGM819S-CAQN5G/TR	0T7 XXXXX	Tape and Reel, 3000
SGM819S-CBQ	SOT-23-5	-40°C to +125°C	SGM819S-CBQN5G/TR	0T8 XXXXX	Tape and Reel, 3000
SGM819S-DAQ	SOT-23-5	-40°C to +125°C	SGM819S-DAQN5G/TR	0T9 XXXXX	Tape and Reel, 3000
SGM819S-DBQ	SOT-23-5	-40°C to +125°C	SGM819S-DBQN5G/TR	0TA XXXXX	Tape and Reel, 3000
SGM819S-EAQ	SOT-23-5	-40°C to +125°C	SGM819S-EAQN5G/TR	0TB XXXXX	Tape and Reel, 3000
SGM819S-EBQ	SOT-23-5	-40°C to +125°C	SGM819S-EBQN5G/TR	0TC XXXXX	Tape and Reel, 3000
SGM819S-FAQ	SOT-23-5	-40°C to +125°C	SGM819S-FAQN5G/TR	0TD XXXXX	Tape and Reel, 3000
SGM819S-FBQ	SOT-23-5	-40°C to +125°C	SGM819S-FBQN5G/TR	0TE XXXXX	Tape and Reel, 3000

**MARKING INFORMATION**

NOTE: XXXXX = Date Code, Trace Code and Vendor Code.

**XXXXX**

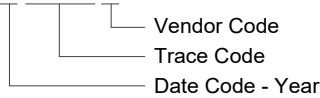

Green (RoHS & HSF): SG Micro Corp defines "Green" to mean Pb-Free (RoHS compatible) and free of halogen substances. If you have additional comments or questions, please contact your SGMICRO representative directly.

**ABSOLUTE MAXIMUM RATINGS**

- Supply Voltage,  $V_{CC}$ ..... -0.3V to 7V
- Input or Output Voltage,  $V_{IN}$ ,  $V_{OUT}$ .....-0.3V to  $V_{CC} + 0.3V$
- Output Current.....20mA
- Package Thermal Resistance
- SOT-23-5,  $\theta_{JA}$ .....180.1°C/W
- SOT-23-5,  $\theta_{JB}$ .....46°C/W
- SOT-23-5,  $\theta_{JC}$ .....69.5°C/W
- Junction Temperature.....+150°C
- Storage Temperature Range.....-65°C to +150°C
- Lead Temperature (Soldering, 10s).....+260°C
- ESD Susceptibility
- HBM.....4000V
- CDM.....1000V

**RECOMMENDED OPERATING CONDITIONS**

- Supply Voltage,  $V_{CC}$ .....1.7V to 5.5V
- Input Rise and Fall Times..... $\leq 5ns$
- Input Pulse Voltages.....0.2V to  $0.8 \times V_{CC}$
- Operating Junction Temperature Range.....-40°C to +125°C

**OVERSTRESS CAUTION**

Stresses beyond those listed in Absolute Maximum Ratings may cause permanent damage to the device. Exposure to absolute maximum rating conditions for extended periods may affect reliability. Functional operation of the device at any conditions beyond those indicated in the Recommended Operating Conditions section is not implied.

**ESD SENSITIVITY CAUTION**

This integrated circuit can be damaged if ESD protections are not considered carefully. SGMICRO recommends that all integrated circuits be handled with appropriate precautions. Failure to observe proper handling and installation procedures can cause damage. ESD damage can range from subtle performance degradation to complete device failure. Precision integrated circuits may be more susceptible to damage because even small parametric changes could cause the device not to meet the published specifications.

**DISCLAIMER**

SG Micro Corp reserves the right to make any change in circuit design, or specifications without prior notice.

PIN CONFIGURATION

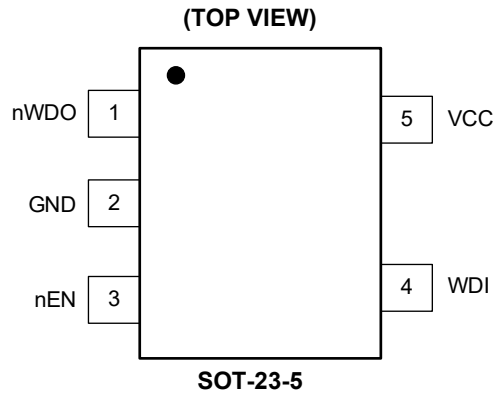

PIN DESCRIPTION

PIN	NAME	FUNCTION
1	nWDO	Watchdog Output Pin.
2	GND	Ground.
3	nEN	Active-Low Enable Input Pin.
4	WDI	Watchdog Input Pin. This pin cannot be left floating.
5	VCC	Supply Voltage.

FUNCTIONAL BLOCK DIAGRAM

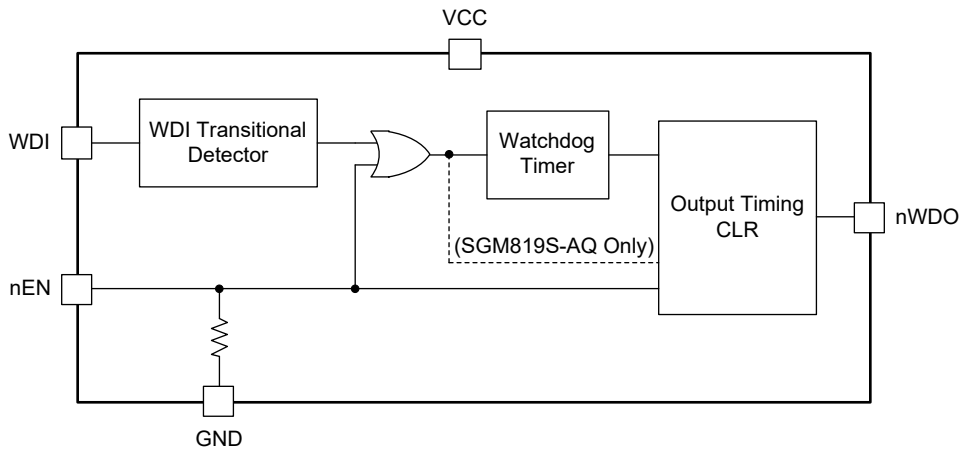

NOTE: If the positive pulse on the enable pin, nEN, is longer than 1μs, it resets the watchdog.

Figure 2. Block Diagram

**ELECTRICAL CHARACTERISTICS**(V<sub>CC</sub> = 1.7V to 5.5V, T<sub>J</sub> = -40°C to +125°C, typical values are measured at T<sub>J</sub> = +25°C, unless otherwise noted.)

PARAMETER	SYMBOL	CONDITIONS	MIN	TYP	MAX	UNITS
Operating Voltage	V <sub>CC</sub>		1.7	3.3	5.5	V
VCC Supply Current	I <sub>CC</sub>			3.5	10	μA
Open-Drain Output Leakage Current	I <sub>LO</sub>	From output to the GND or VCC	-1		1	μA
WDI Input Leakage Current			-1		1	μA
WDI, nEN Input High Voltage	V <sub>IH</sub>		0.7 × V <sub>CC</sub>			V
WDI, nEN Input Low Voltage	V <sub>IL</sub>				0.3 × V <sub>CC</sub>	V
nWDO Output Voltage		I <sub>SINK</sub> = 1.2mA			0.2	V
		I <sub>SINK</sub> = 3.2mA			0.4	
<b>Enable Pin (nEN)</b>						
nEN Input Pulse Width			1			μs
nEN Glitch Rejection				100		ns
nEN to nWDO delay <sup>(1)</sup>				120		ns
nEN Pull-Down Resistance			40	70	100	kΩ
<b>Watchdog Timer</b>						
Timer Startup Voltage	V <sub>START</sub>		1.26	1.41	1.58	V
Watchdog Timeout Period	t <sub>WD</sub>	SGM819S-AQ	2.8	3.4	4.0	ms
		SGM819S-BnQ (n = A, B)	5.5	6.8	8.1	
		SGM819S-CnQ (n = A, B)	87.1	108.8	130.5	
		SGM819S-DnQ (n = A, B)	1.4	1.7	2.08	s
		SGM819S-EnQ (n = A, B)	5.6	7.0	8.3	
		SGM819S-FnQ (n = A, B)	22.3	27.9	33.4	
Watchdog Active Time	t <sub>PW</sub>	SGM819S-mAQ (m = B, C, D, E, F)	21.8	27.2	32.6	ms
		SGM819S-mBQ (m = B, C, D, E, F)	174.1	217.6	261.1	
WDI Pulse Width			1			μs
WDI Glitch Rejection				100		ns
WDI to nWDO Delay <sup>(2)</sup>				100		ns

## NOTES:

- nWDO asserts for minimum of 20μs even if nEN transitions high.
- nWDO asserts for minimum of 20μs regardless of transition on WDI (valid for SGM819S-AQ only).

## DETAILED DESCRIPTION

The SGM819SxQ is a watchdog timer circuit to monitor the operating state of the MCU. A watchdog reset signal must be issued before the watchdog timeout period ends. If not, the watchdog timeout function is activated and the watchdog output is asserted low. The watchdog function can also be turned on or off through nEN pin.

### Watchdog Input (WDI)

The WDI pin is used to periodically reset the watchdog in a watchdog timeout period,  $t_{WD}$ . The WDI pin must be toggled in the period of  $t_{WD}$  or the watchdog output, nWDO, is asserted. The following conditions can reset the watchdog timer:

1. By a transition on nWDO (see Timeout without Re-Trigger section)
2. By a pulse on nEN (see nEN Triggering section)
3. By a transition on WDI (rising edge effective on all versions and falling edge effective on the all versions excluding SGM819S-AQ).

The WDI input detects the pulse width larger than  $1\mu\text{s}$ , and ignores pulse width less than 100ns.

If WDI maintains a stable logic state (high or low) and nEN is logic low, the nWDO of SGM819S-AQ flips every  $t_{WD}$  and the rest versions flip every  $t_{WD}$  and  $t_{PW}$  (see Timeout without Re-Trigger section).

### Watchdog Output (nWDO)

During the power-on process, the watchdog timer begins to count after the VCC voltage is higher than the timer startup voltage,  $V_{START}$ . Once the timer is not reset within  $t_{WD}$ , the nWDO turns to logic low (see Power-On section).

For SGM819S-AQ, the nWDO is asserted low for a period between  $20\mu\text{s}$  and  $t_{WD}$  when the watchdog timeout event occurs (see Timeout without Re-Trigger and Trigger after Timeout sections). For the rest versions, the nWDO is asserted low for  $t_{PW}$  without detecting the WDI transitions (see Trigger after Timeout section).

The nWDO pin is an open-drain structure. Connect this pin to a voltage rail no larger than 6V through an external pull-up resistor as shown in Figure 3. Users should carefully consider the factors such as capacitive loading, logic low output voltage ( $V_{OL}$ ), and the leakage current through the nWDO pin ( $I_{LO}$ ) to select appropriate resistance values. It ensures that the high and low output voltage values meet the requirements of subsequent applications. A 10k $\Omega$  pull-up resistor is recommended in most conditions.

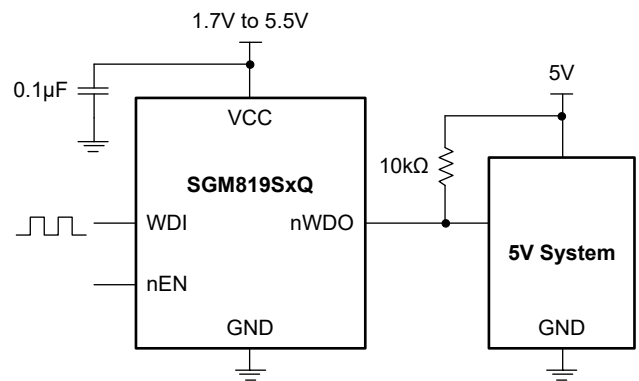

Figure 3. Open-Drain nWDO Output Connection

### Chip Enable Input (nEN)

All those mentioned in Watchdog Input (WDI) and Watchdog Output (nWDO) are described in the precondition that nEN is logic low. The function logic of nEN is the same to all versions of SGM819SxQ.

During the power-on process, if nEN goes high after VCC voltage is higher than  $V_{START}$  but before  $t_{WD}$ , the nWDO keeps high as long as nEN is high. Once nEN goes low, the nWDO is asserted after  $t_{WD}$ . If nEN goes high at any time of nWDO, the nWDO goes high immediately. Note that the minimum nWDO asserted time is  $20\mu\text{s}$  (see nEN Triggering section).

The nEN input detects the pulse width larger than  $1\mu\text{s}$ , and ignores pulse width less than 100ns.

**TIMING DIAGRAM**

**Power-On**

In the power-on process, the watchdog timer starts running once  $V_{CC}$  rises above about  $V_{START}$ .

Transitions of WDI do not matter. WDI can be either logic high or low but not floating. For the SGM819S-AQ, low-to-high edge on WDI will clear the watchdog timer. For the other models, both low-to-high edge and high-to-low edge on WDI will clear the watchdog timer. WDI transition has nothing to do with starting the watchdog timing.

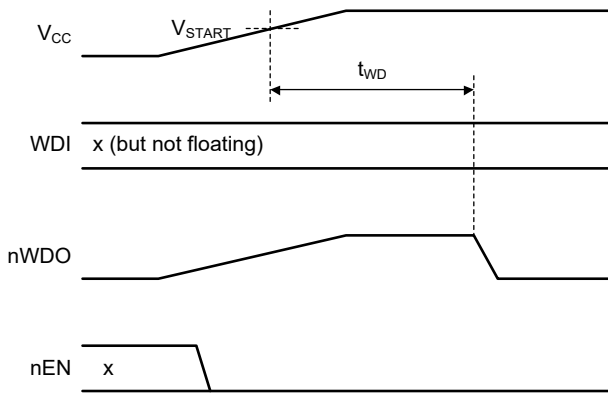

Figure 4. Power-On Timing Diagram of SGM819SxQ

**Normal Triggering**

For the SGM819S-AQ, only rising edge of WDI is effective. Falling edge is invalid.

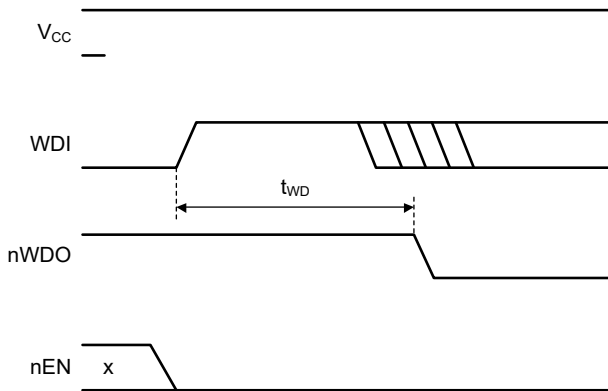

Figure 5. Normal Triggering Timing Diagram of SGM819S-AQ

For the other models, both rising edge and falling edge are effective.

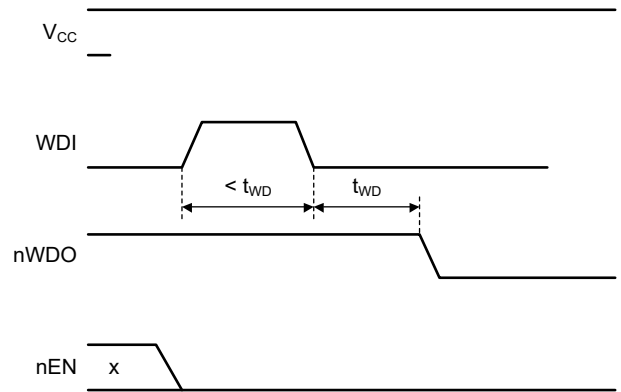

Figure 6. Normal Triggering Timing Diagram of All Models except SGM819S-AQ

**Timeout without Re-Trigger**

For the SGM819S-AQ, when a timeout event occurs, nWDO will be asserted low for  $t_{WD}$  and then goes high. Once no rising edge of WDI is detected within  $t_{WD}$ , nWDO will be asserted low for  $t_{WD}$  again. The nWDO keeps this way unless a rising edge of WDI is detected.

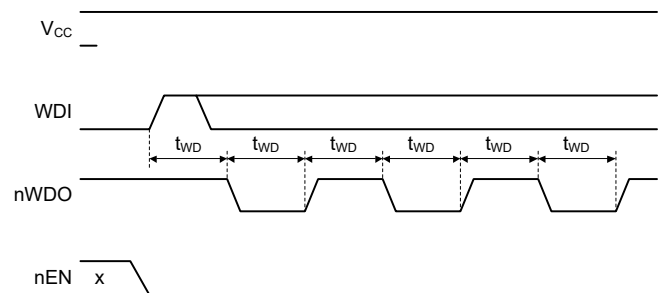

Figure 7. Timeout without Re-Trigger Timing Diagram of SGM819S-AQ

For the other models, when a timeout event occurs, nWDO will be asserted low for  $t_{PW}$  and then goes high. Once no rising/falling edge of WDI is detected within  $t_{WD}$ , nWDO will be asserted low for  $t_{PW}$  again. The nWDO keeps this way unless a rising or falling edge of WDI is detected.

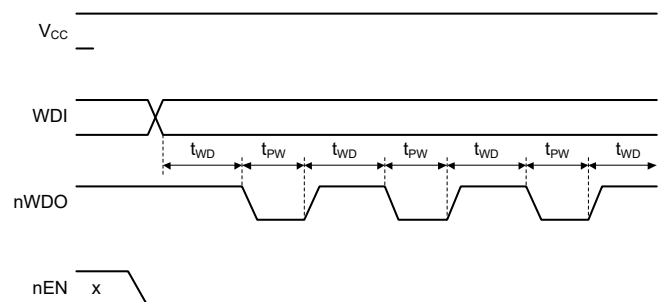

Figure 8. Timeout without Re-Trigger Timing Diagram of All Models except SGM819S-AQ

TIMING DIAGRAM (continued)

Trigger after Timeout

For the SGM819S-AQ, when the WDI goes high after the nWDO is asserted low, the nWDO will be asserted for minimum 20µs regardless of the WDI transitions.

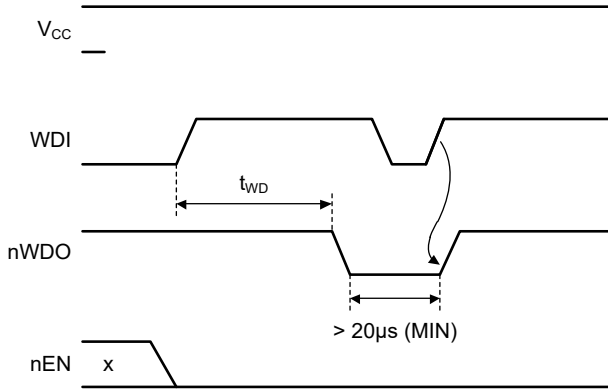

Figure 9. Trigger after Timeout Timing Diagram of SGM819S-AQ

For the other models, when the WDI goes high after the nWDO is asserted low, the trigger of WDI is invalid and the nWDO will be asserted for  $t_{PW}$ . Trigger of WDI is ignored when nWDO is low.

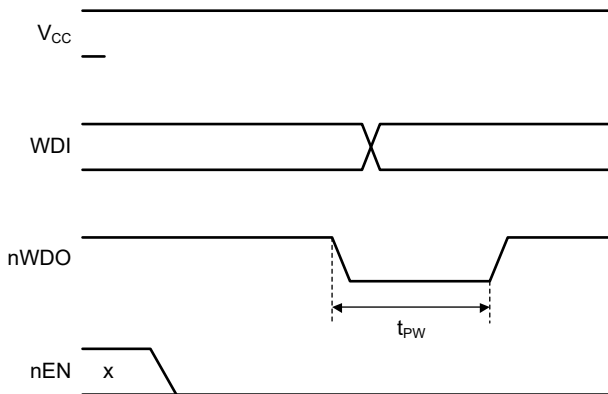

Figure 10. Trigger after Timeout Timing Diagram of All Models except SGM819S-AQ

nEN Triggering

For all versions of SGM819SxQ, once nEN goes high, all timing is cleared and the watchdog is disabled. Timing counts again from 0 when nEN goes low. WDI can be either logic high or low but not floating.

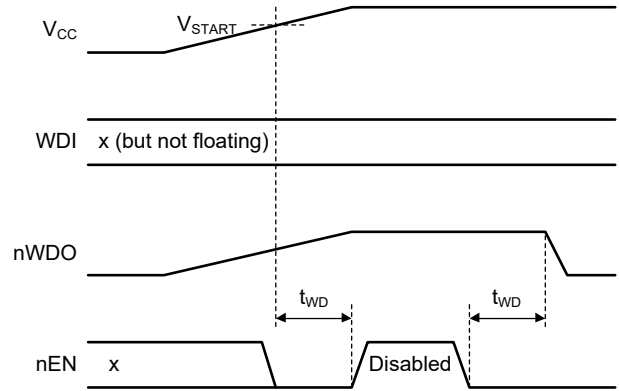

Figure 11. nEN Triggering Diagram 1

For all versions of SGM819SxQ, when nEN goes high in the asserted state of nWDO, the nWDO will be asserted for minimum 20µs regardless of the nEN transitions. WDI can be either logic high or low but not floating.

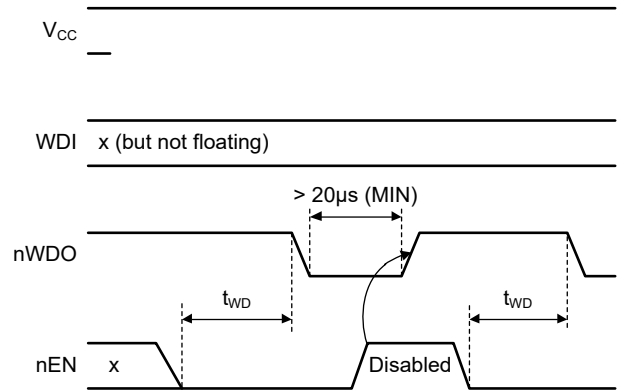
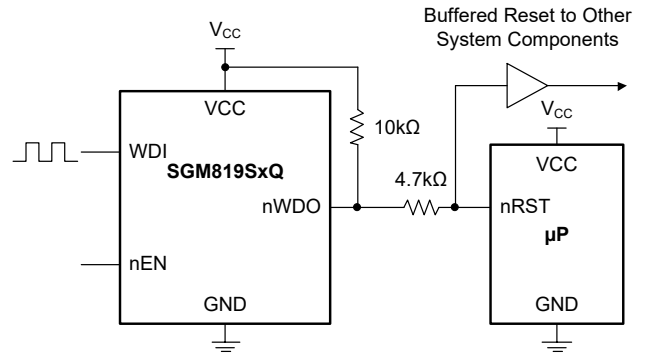

Figure 12. nEN Triggering Diagram 2

**APPLICATION INFORMATION**

**Interfacing to  $\mu$ P with Bidirectional Reset Pins**

The reset pin of some  $\mu$ P devices is bidirectional and can be connected with nWDO of SGM819SxQ. Connecting the nWDO output of SGM819SxQ to nRST output of  $\mu$ P directly may cause race conditions and hazards. For example, if nWDO is logic high and the nRST is logic low, connecting them directly may result in indeterminate logic levels or even damage the nRST pin of  $\mu$ P. Therefore, a 4.7k $\Omega$  resistor is recommended to be connected between nWDO and the  $\mu$ P reset I/O as show in Figure 13. Besides, buffer the nWDO output to reset other system components.



**Figure 13. Interfacing to  $\mu$ P with Bidirectional Reset I/O**

**REVISION HISTORY**

NOTE: Page numbers for previous revisions may differ from page numbers in the current version.

Changes from Original (JULY 2024) to REV.A	Page
Changed from product preview to production data.....	All



# PACKAGE INFORMATION

## PACKAGE OUTLINE DIMENSIONS

### SOT-23-5

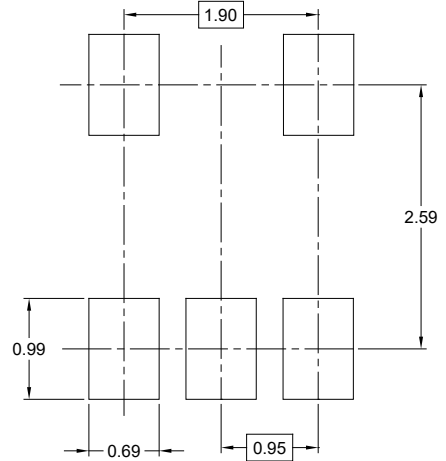
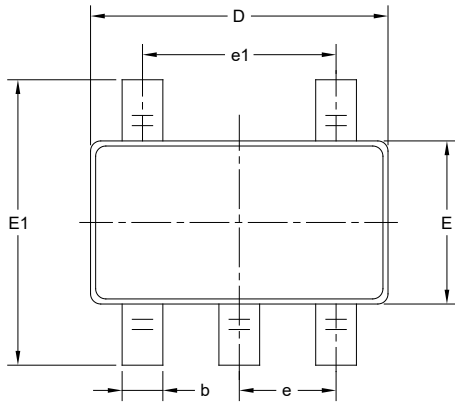

RECOMMENDED LAND PATTERN (Unit: mm)

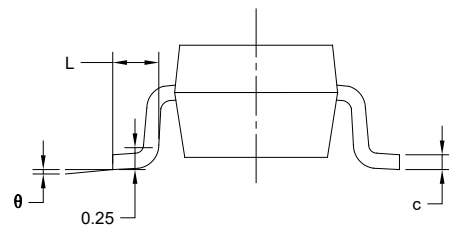
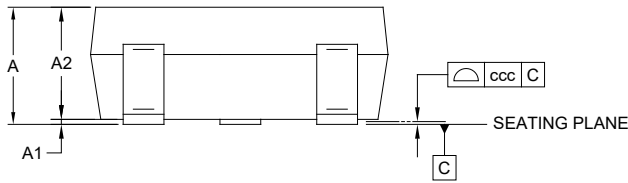

Symbol	Dimensions In Millimeters		
	MIN	NOM	MAX
A	-	-	1.450
A1	0.000	-	0.150
A2	0.900	-	1.300
b	0.300	-	0.500
c	0.080	-	0.220
D	2.750	-	3.050
E	1.450	-	1.750
E1	2.600	-	3.000
e	0.950 BSC		
e1	1.900 BSC		
L	0.300	-	0.600
$\theta$	0°	-	8°
ccc	0.100		

NOTES:

1. This drawing is subject to change without notice.
2. The dimensions do not include mold flashes, protrusions or gate burrs.
3. Reference JEDEC MO-178.

# PACKAGE INFORMATION

## TAPE AND REEL INFORMATION

### REEL DIMENSIONS

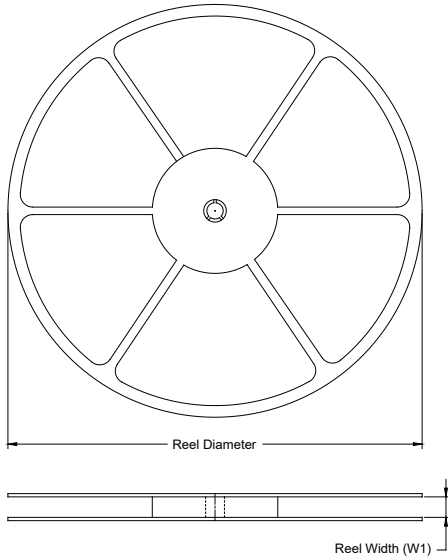

### TAPE DIMENSIONS

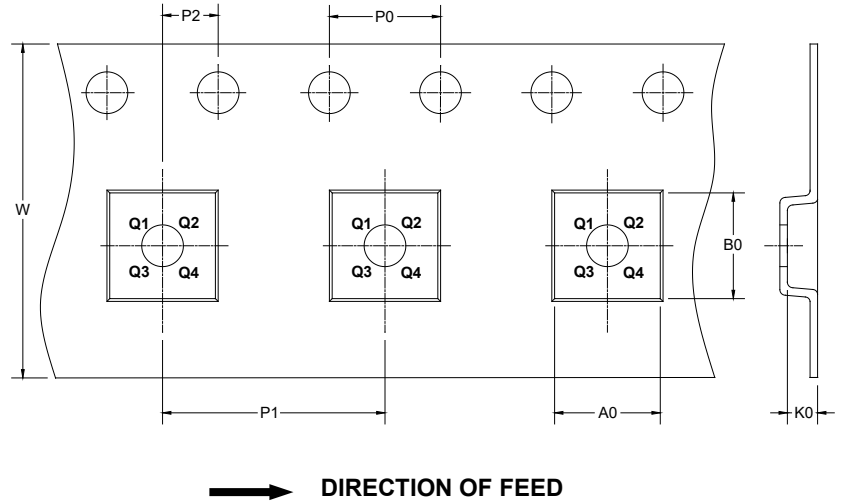

NOTE: The picture is only for reference. Please make the object as the standard.

### KEY PARAMETER LIST OF TAPE AND REEL

Package Type	Reel Diameter	Reel Width W1 (mm)	A0 (mm)	B0 (mm)	K0 (mm)	P0 (mm)	P1 (mm)	P2 (mm)	W (mm)	Pin1 Quadrant
SOT-23-5	7"	9.5	3.20	3.20	1.40	4.0	4.0	2.0	8.0	Q3

DD0001

# PACKAGE INFORMATION

## CARTON BOX DIMENSIONS

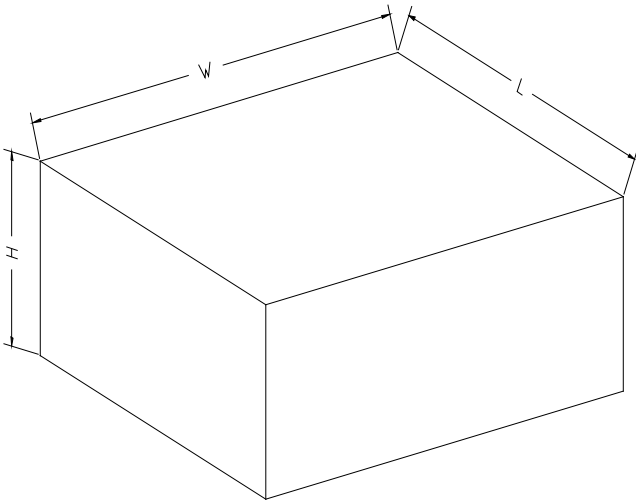

NOTE: The picture is only for reference. Please make the object as the standard.

## KEY PARAMETER LIST OF CARTON BOX

Reel Type	Length (mm)	Width (mm)	Height (mm)	Pizza/Carton
7" (Option)	368	227	224	8
7"	442	410	224	18

D00002