



# SGM721Q

## Automotive, 11MHz, Rail-to-Rail I/O CMOS Operational Amplifier

### GENERAL DESCRIPTION

The SGM721Q is a single, low voltage, low noise and low power operational amplifier for automotive applications. This device can operate from 2.1V to 5.5V single supply, and consumes low quiescent current.

The SGM721Q features a  $\pm 6.5\text{mV}$  maximum input offset voltage. The minimum input common mode voltage is within 0.1V below the negative rail, and the output swing is rail-to-rail with heavy loads. It exhibits a high gain-bandwidth product of 11MHz and a slew rate of  $7\text{V}/\mu\text{s}$ . These specifications make the operational amplifier appropriate for various applications.

The device is AEC-Q100 qualified (Automotive Electronics Council (AEC) standard Q100 Grade 1) and it is suitable for automotive applications.

The SGM721Q is available in a Green SOT-23-5 package. It operates over an ambient temperature range of  $-40^\circ\text{C}$  to  $+125^\circ\text{C}$ .

### FEATURES

- **AEC-Q100 Qualified for Automotive Applications**  
Device Temperature Grade 1  
 $T_A = -40^\circ\text{C}$  to  $+125^\circ\text{C}$
- **Input Offset Voltage:  $\pm 6.5\text{mV}$  (MAX)**
- **High Gain-Bandwidth Product: 11MHz**
- **High Slew Rate:  $7\text{V}/\mu\text{s}$**
- **Settling Time to 0.1% with 2V Step:  $0.4\mu\text{s}$**
- **Overload Recovery Time:  $0.5\mu\text{s}$**
- **Low Noise:  $8.5\text{nV}/\sqrt{\text{Hz}}$  at 10kHz**
- **Rail-to-Rail Input and Output**
- **Supply Voltage Range: 2.1V to 5.5V**
- **Input Voltage Range:  $-0.1\text{V}$  to  $5.6\text{V}$  with  $V_S = 5.5\text{V}$**
- **Low Quiescent Current: 1.2mA (TYP)**
- **Available in a Green SOT-23-5 Package**

### APPLICATIONS

Automotive Application  
Sensor  
Automotive Inverter  
Automotive Audio  
Active Filter  
Driver of A/D Converter  
Photodiode Amplification



## ELECTRICAL CHARACTERISTICS

(At  $T_A = +25^\circ\text{C}$ ,  $V_S = 2.1\text{V to } 5\text{V}$ ,  $V_{CM} = V_S/2$  and  $R_L = 600\Omega$ , unless otherwise noted.)

| PARAMETER   | CONDITIONS   | TYP         | MIN/MAX OVER TEMPERATURE |                |                 |                              | UNITS | MIN/MAX |
|---|--|-------------|--------------------------|----------------|-----------------|------------------------------|-------|---------|
|   |  | +25°C       | +25°C                    | -40°C to +85°C | -40°C to +125°C |                              |       |         |
| <b>Input Characteristics</b>                            |  |             |                          |                |                 |                              |       |         |
| Input Offset Voltage ( $V_{OS}$ )                       |  | ±2          | ±5.5                     | ±6             | ±6.5            | mV                           | MAX   |         |
| Input Bias Current ( $I_B$ )                            |  | 0.01        |                          | 1              | 6               | nA                           | MAX   |         |
| Input Offset Current ( $I_{OS}$ )                       |  | 0.01        |                          | 1              | 3               | nA                           | MAX   |         |
| Input Common Mode Voltage Range ( $V_{CM}$ )            | $V_S = 5.5\text{V}$  | -0.1 to 5.6 |                          |                |                 | V                            | TYP   |         |
| Common Mode Rejection Ratio (CMRR)                      | $V_S = 2.1\text{V}$ , $V_{CM} = -0.1\text{V to } 2.2\text{V}$                    | 67          | 53                       | 50             | 46              | dB                           | MIN   |         |
|   | $V_S = 5.5\text{V}$ , $V_{CM} = -0.1\text{V to } 4\text{V}$                      | 81          | 66                       | 63             | 61              | dB                           | MIN   |         |
|   | $V_S = 5.5\text{V}$ , $V_{CM} = -0.1\text{V to } 5.6\text{V}$                    | 75          | 60                       | 57             | 55              | dB                           | MIN   |         |
| Open-Loop Voltage Gain ( $A_{OL}$ )                     | $R_L = 600\Omega$ ,<br>$V_{OUT} = 0.15\text{V to } (+V_S) - 0.15\text{V}$        | 86          | 80                       | 72             | 62              | dB                           | MIN   |         |
|   | $R_L = 10\text{k}\Omega$ ,<br>$V_{OUT} = 0.05\text{V to } (+V_S) - 0.15\text{V}$ | 98          | 91                       | 80             | 68              | dB                           | MIN   |         |
| Input Offset Voltage Drift ( $\Delta V_{OS}/\Delta T$ ) |  | 5.5         |                          |                |                 | $\mu\text{V}/^\circ\text{C}$ | TYP   |         |
| <b>Output Characteristics</b>                           |  |             |                          |                |                 |                              |       |         |
| Output Voltage Swing from Rail                          | $R_L = 600\Omega$  | 76          | 100                      | 110            | 120             | mV                           | MAX   |         |
|   | $R_L = 10\text{k}\Omega$   | 6           | 20                       | 30             | 40              | mV                           | MAX   |         |
| Output Current ( $I_{OUT}$ )                            | $V_S = 2.1\text{V}$  | ±25         | ±19                      | ±15            | ±13             | mA                           | MIN   |         |
|   | $V_S = 5\text{V}$  | ±58         | ±48                      | ±38            | ±34             | mA                           | MIN   |         |
| Closed-Loop Output Impedance                            | $f = 1\text{MHz}$ , $G = +1$   | 9.5         |                          |                |                 | $\Omega$                     | TYP   |         |
| <b>Power Supply</b>                                     |  |             |                          |                |                 |                              |       |         |
| Operating Voltage Range                                 |  |             |                          |                | 2.1             | V                            | MIN   |         |
|   |  |             |                          |                | 5.5             | V                            | MAX   |         |
| Power Supply Rejection Ratio (PSRR)                     | $V_S = 2.1\text{V to } 5.5\text{V}$ , $V_{CM} = (-V_S) + 0.5\text{V}$            | 79          | 67                       | 64             | 62              | dB                           | MIN   |         |
| Quiescent Current ( $I_Q$ )                             | $I_{OUT} = 0\text{A}$  | 1.2         | 1.5                      | 1.7            | 1.85            | mA                           | MAX   |         |
| <b>Dynamic Performance</b>                              |  |             |                          |                |                 |                              |       |         |
| Gain-Bandwidth Product (GBP)                            | $C_L = 50\text{pF}$  | 11          |                          |                |                 | MHz                          | TYP   |         |
| Phase Margin ( $\phi_O$ )                               | $C_L = 50\text{pF}$  | 60          |                          |                |                 | °                            | TYP   |         |
| Full-Power Bandwidth ( $BW_P$ )                         | < 1% distortion, $V_{OUT} = 1V_{P-P}$  | 200         |                          |                |                 | kHz                          | TYP   |         |
| Slew Rate (SR)  | $G = +1$   | 6           |                          |                |                 | $\text{V}/\mu\text{s}$       | TYP   |         |
| Settling Time to 0.1% ( $t_S$ )                         | $G = +1$   | 0.4         |                          |                |                 | $\mu\text{s}$                | TYP   |         |
| Overload Recovery Time                                  | $V_{IN} \times G = V_S$  | 0.8         |                          |                |                 | $\mu\text{s}$                | TYP   |         |
| <b>Noise Performance</b>                                |  |             |                          |                |                 |                              |       |         |
| Input Voltage Noise Density ( $e_n$ )                   | $f = 1\text{kHz}$  | 12.5        |                          |                |                 | $\text{nV}/\sqrt{\text{Hz}}$ | TYP   |         |
|   | $f = 10\text{kHz}$   | 8.5         |                          |                |                 | $\text{nV}/\sqrt{\text{Hz}}$ | TYP   |         |

TYPICAL PERFORMANCE CHARACTERISTICS

At  $T_A = +25^\circ\text{C}$ ,  $V_S = 5\text{V}$ , unless otherwise noted.

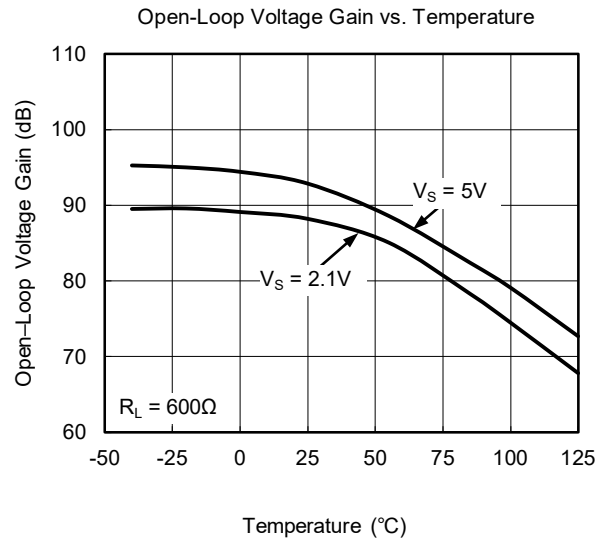
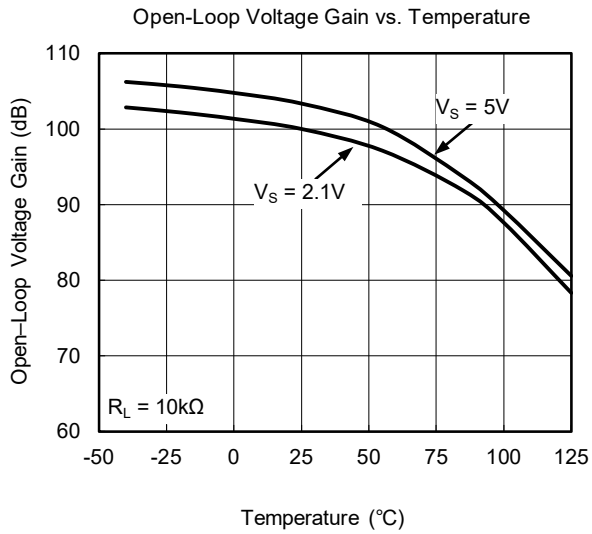
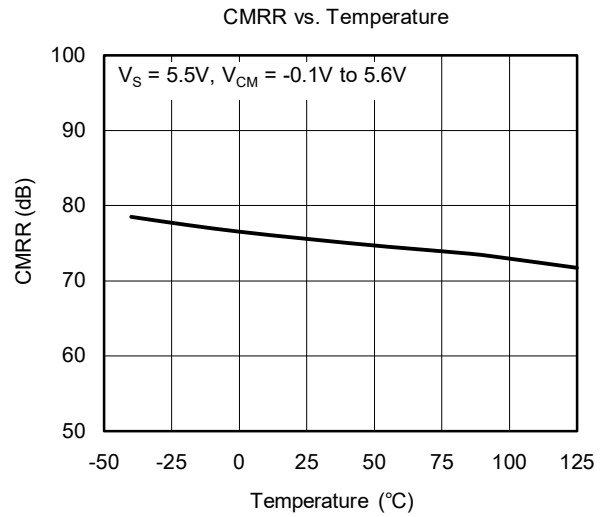
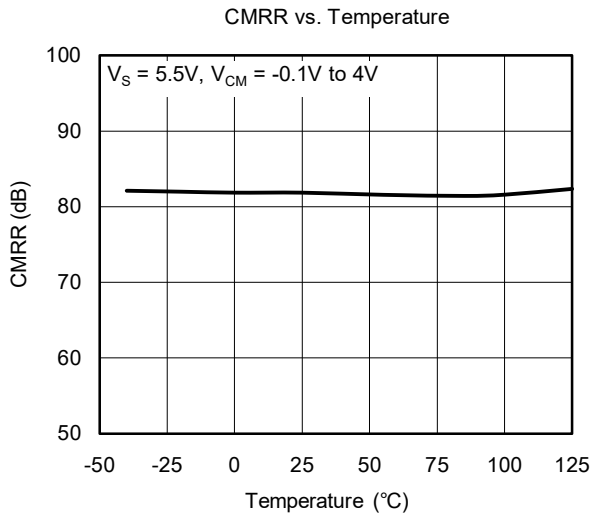
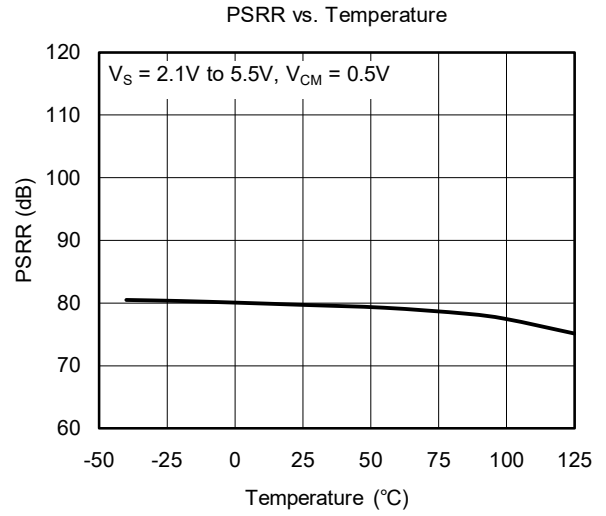
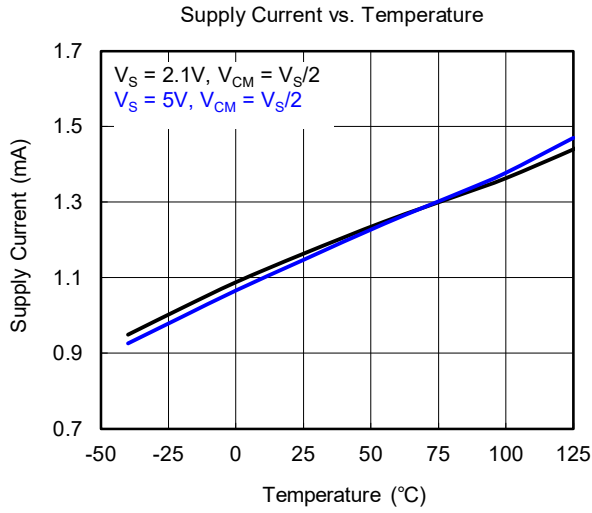

**TYPICAL PERFORMANCE CHARACTERISTICS (continued)**

At  $T_A = +25^\circ\text{C}$ ,  $V_S = 5\text{V}$ , unless otherwise noted.

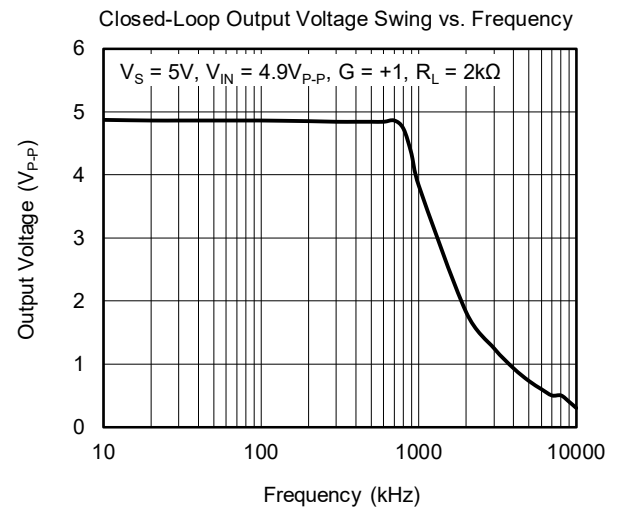
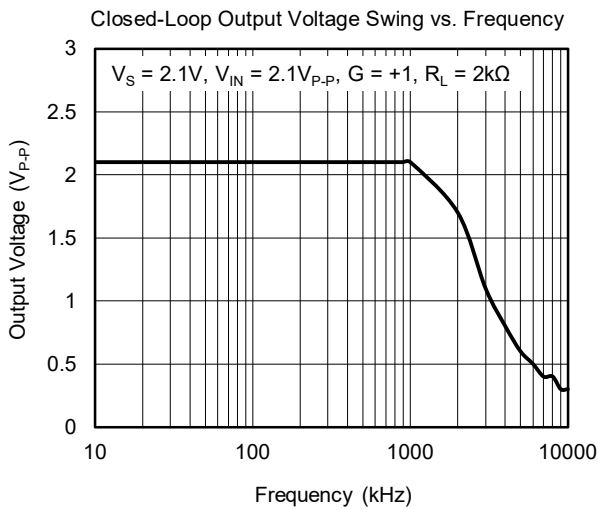
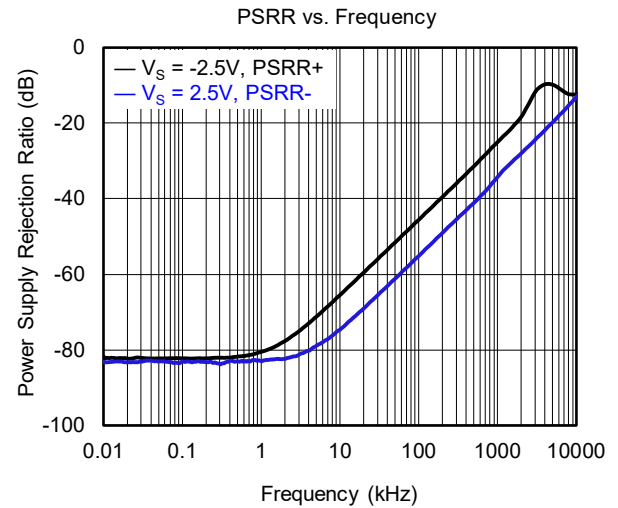
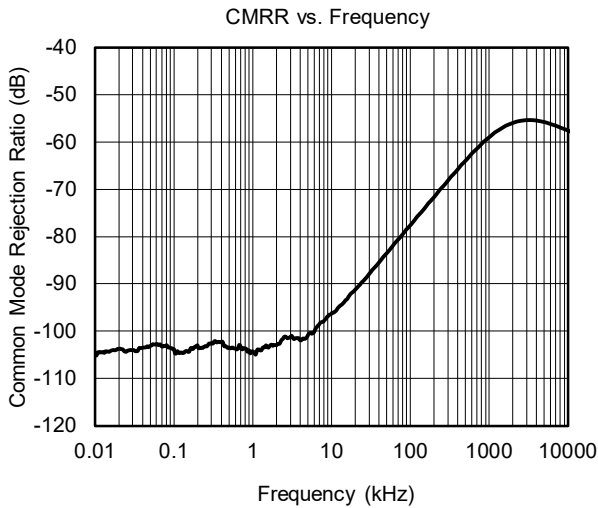
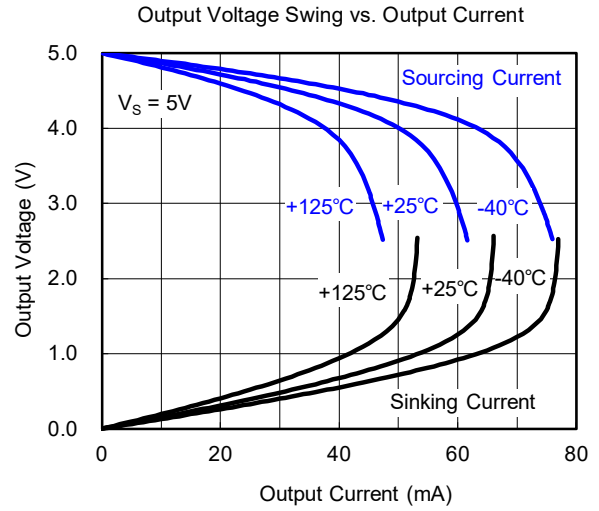
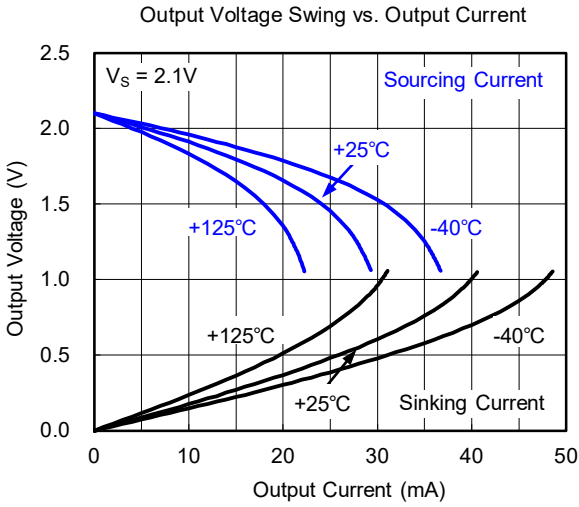

TYPICAL PERFORMANCE CHARACTERISTICS (continued)

At  $T_A = +25^\circ\text{C}$ ,  $V_S = 5\text{V}$ , unless otherwise noted.

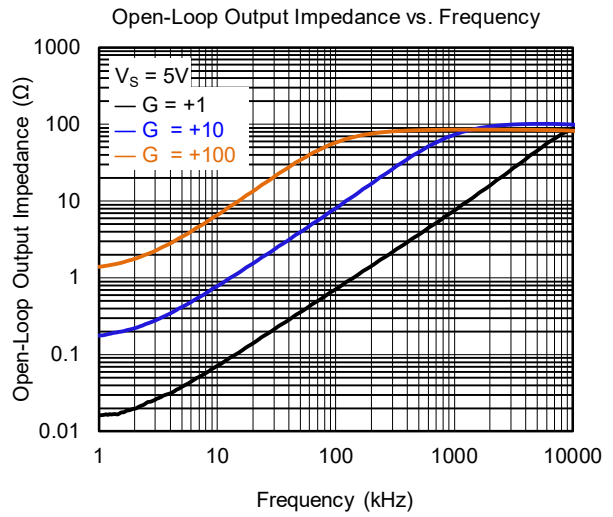
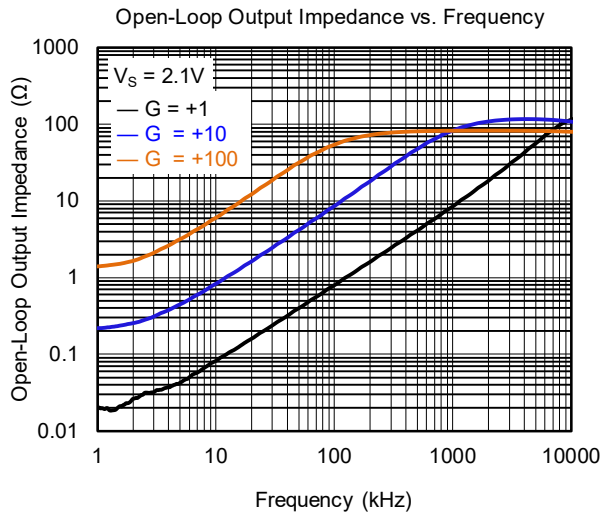
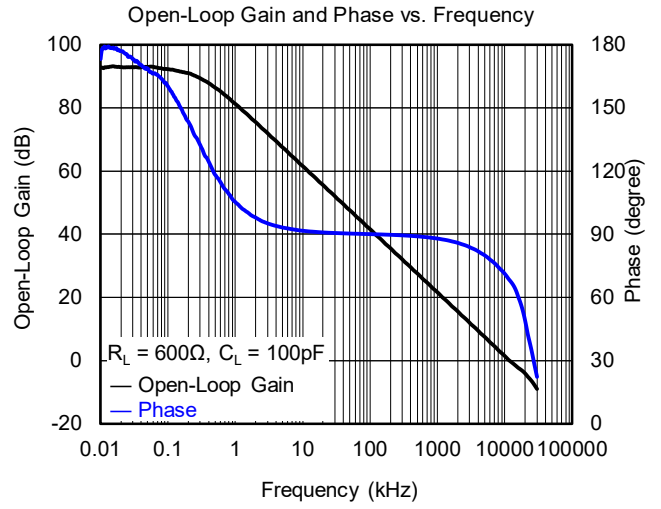
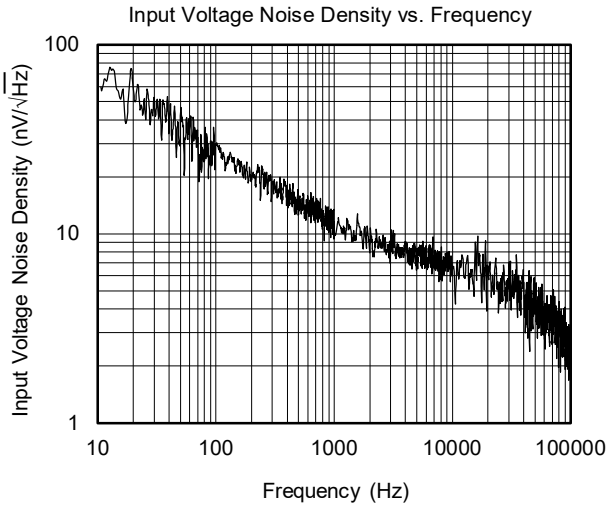

TYPICAL PERFORMANCE CHARACTERISTICS (continued)

At  $T_A = +25^\circ\text{C}$ ,  $V_S = 5\text{V}$ , unless otherwise noted.

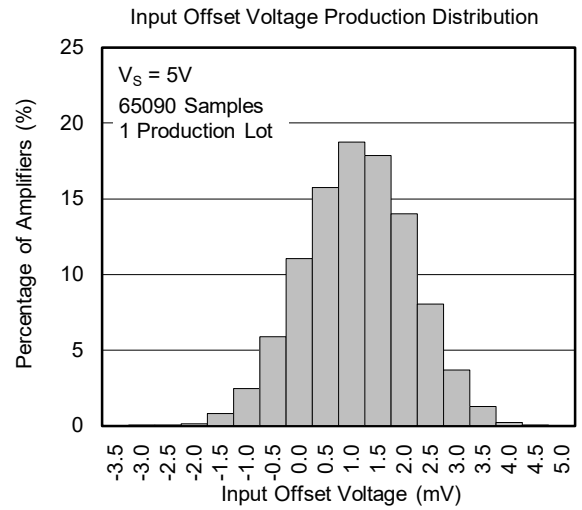
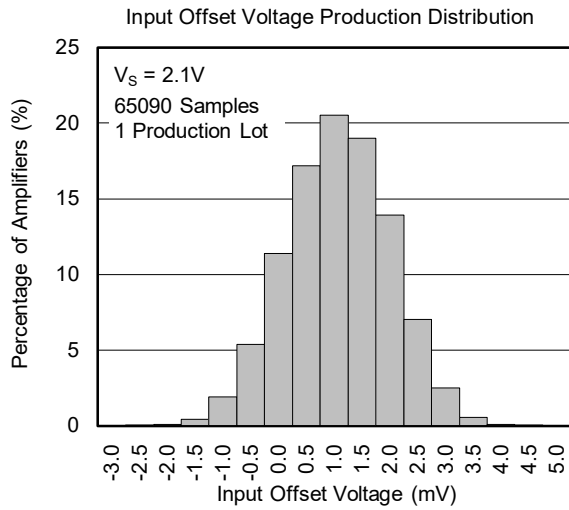
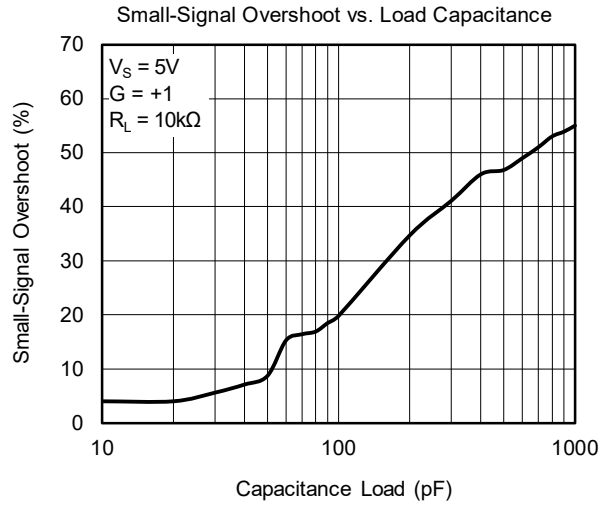
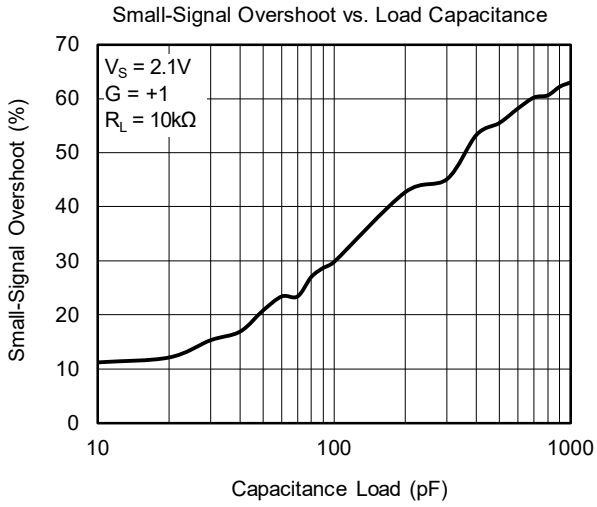

TYPICAL PERFORMANCE CHARACTERISTICS (continued)

At  $T_A = +25^\circ\text{C}$ ,  $V_S = 5\text{V}$ , unless otherwise noted.

Small-Signal Step Response

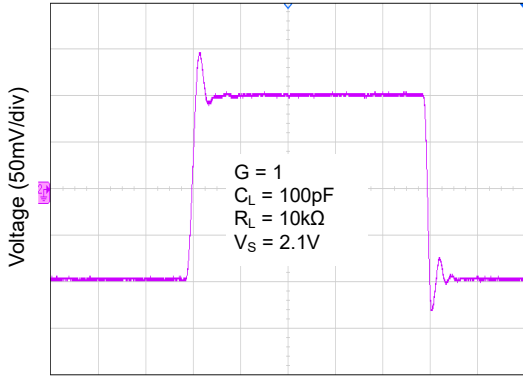

Time (200ns/div)

Small-Signal Step Response

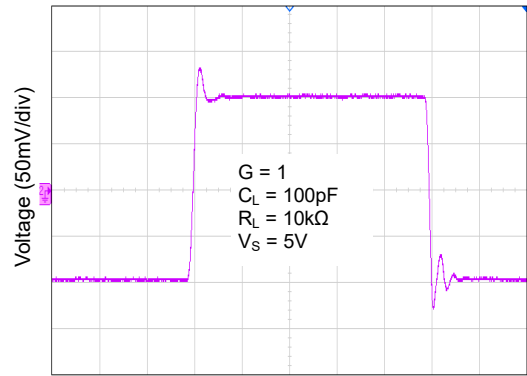

Time (200ns/div)

Large-Signal Step Response

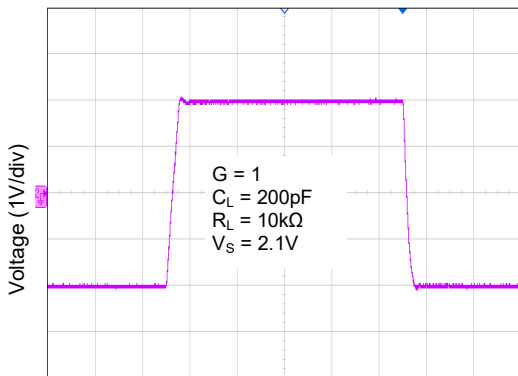

Time (1μs/div)

Large-Signal Step Response

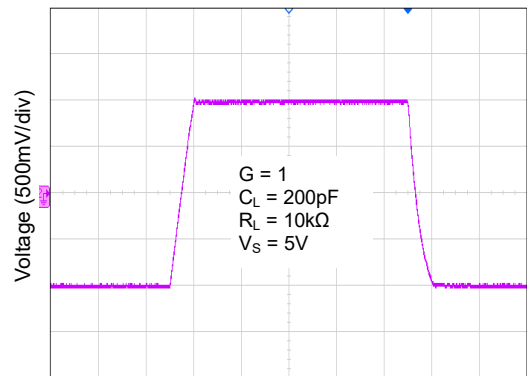

Time (1μs/div)

Positive Overload Recovery

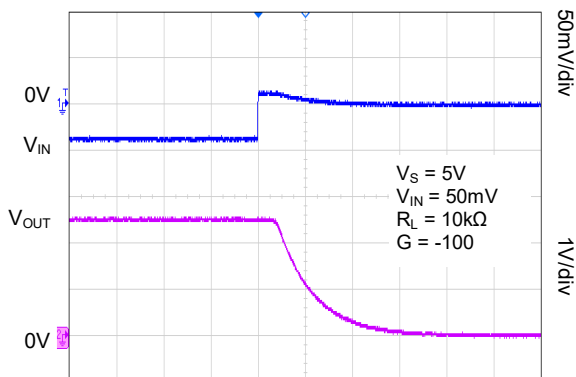

Time (1μs/div)

Negative Overload Recovery

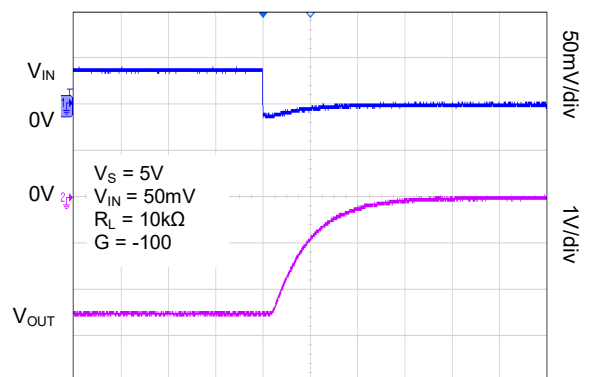

Time (1μs/div)



**APPLICATION INFORMATION**

**Rail-to-Rail Input**

When SGM721Q works at the power supply between 2.1V and 5.5V, the input common mode voltage range is from  $(-V_S) - 0.1V$  to  $(+V_S) + 0.1V$ . In Figure 1, the ESD diodes between the inputs and the power supply rails will clamp the input voltage not to exceed the rails.

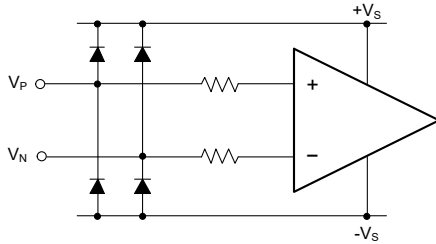

Figure 1. Input Equivalent Circuit

**Input Current-Limit Protection**

For ESD diode clamping protection, when the current flowing through ESD diode exceeds the maximum rating value, the ESD diode and amplifier will be damaged, so current-limit protection will be added in some applications. One resistor is selected to limit the current not to exceed the maximum rating value. In Figure 2, a series input resistor is used to limit the input current to less than 10mA, but the drawback of this current-limit resistor is that it contributes thermal noise at the amplifier input. If this resistor must be added, its value must be selected as small as possible.

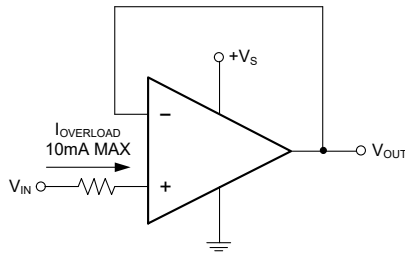

Figure 2. Input Current-Limit Protection

**Rail-to-Rail Output**

The SGM721Q supports rail-to-rail output operation. In single power supply application, for example, when  $+V_S = 5V$ ,  $-V_S = GND$ , 10kΩ load resistor is tied from OUT pin to ground, the typical output swing range is from 0.006V to 4.994V.

**Driving Capacitive Loads**

The SGM721Q is designed for driving the 4700pF capacitive load with unity-gain stable. If greater capacitive load must be driven in application, the circuit in Figure 3 can be used. In this circuit, the IR drop voltage generated by  $R_{ISO}$  is compensated by feedback loop.

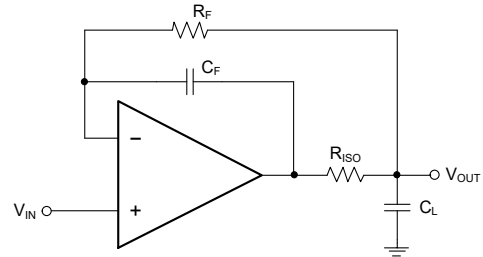

Figure 3. Circuit to Drive Heavy Capacitive Load

**Power Supply Decoupling and Layout**

A clean and low noise power supply is very important in amplifier circuit design. Besides of input signal noise, the power supply is one of important source of noise to the amplifier through  $+V_S$  and  $-V_S$  pins. Power supply bypassing is an effective method to clear up the noise at power supply, and the low impedance path to ground of decoupling capacitor will bypass the noise to GND. In application, 10μF ceramic capacitor paralleled with 0.1μF or 0.01μF ceramic capacitor is used in Figure 4. The ceramic capacitors should be placed as close as possible to  $+V_S$  and  $-V_S$  power supply pins.

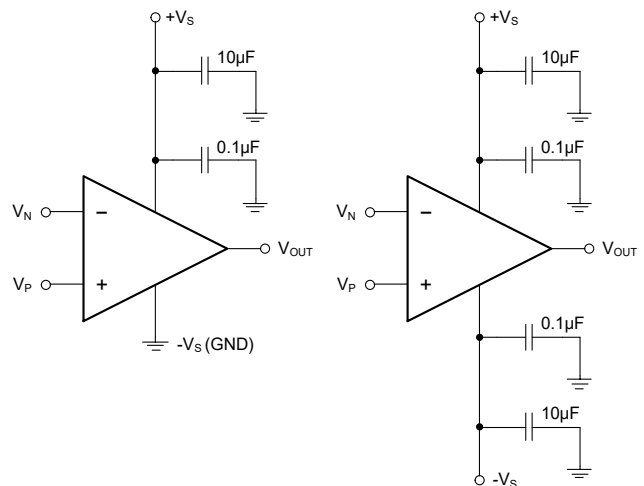

Figure 4. Amplifier Power Supply Bypassing

**APPLICATION INFORMATION (continued)**

**Grounding**

In low speed application, one node grounding technique is the simplest and most effective method to eliminate the noise generated by grounding. In high speed application, the general method to eliminate noise is to use a complete ground plane technique, and the whole ground plane will help distribute heat and reduce EMI noise pickup.

**Reduce Input-to-Output Coupling**

To reduce the input-to-output coupling, the input traces must be placed as far away from the power supply or output traces as possible. The sensitive trace must not be placed in parallel with the noisy trace in same layer. They must be placed perpendicularly in different layers to reduce the crosstalk. These PCB layout techniques will help to reduce unwanted positive feedback and noise.

**Typical Application Circuits**

**Difference Amplifier**

The circuit in Figure 5 is a design example of classical difference amplifier. If  $R_4/R_3 = R_2/R_1$ , then  $V_{OUT} = (V_P - V_N) \times R_2/R_1 + V_{REF}$ .

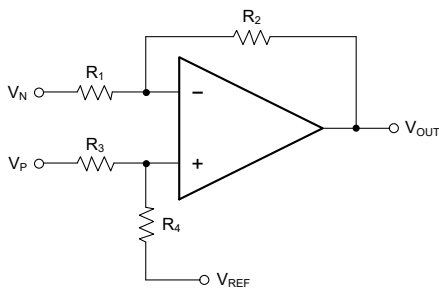

Figure 5. Difference Amplifier

**High Input Impedance Difference Amplifier**

The circuit in Figure 6 is a design example of high input impedance difference amplifier. The added amplifiers at

the input are used to increase the input impedance and eliminate drawback of low input impedance in Figure 5.

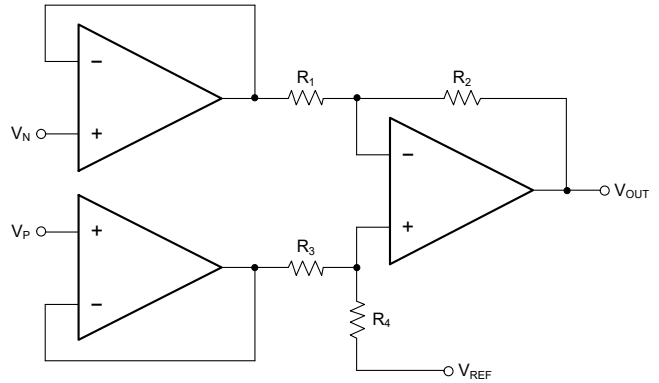

Figure 6. High Input Impedance Difference Amplifier

**Active Low-Pass Filter**

The circuit in Figure 7 is a design example of active low-pass filter, the DC gain is equal to  $-R_2/R_1$  and the -3dB corner frequency is equal to  $1/2\pi R_2 C$ . In this design, the filter bandwidth must be less than the bandwidth of the amplifier, and resistor values must be selected as low as possible to reduce ringing or oscillation generated by the parasitic parameters in PCB layout.

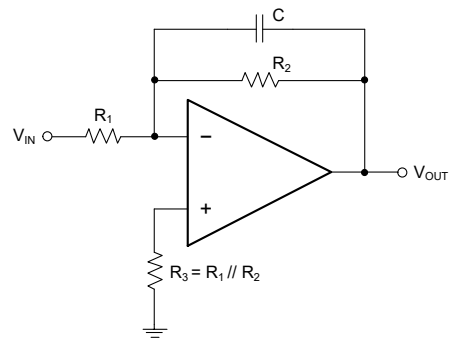

Figure 7. Active Low-Pass Filter

**REVISION HISTORY**

NOTE: Page numbers for previous revisions may differ from page numbers in the current version.

| Changes from Original (APRIL 2024) to REV.A          | Page |
|--|------|
| Changed from product preview to production data..... | All  |

# PACKAGE INFORMATION

## PACKAGE OUTLINE DIMENSIONS

### SOT-23-5

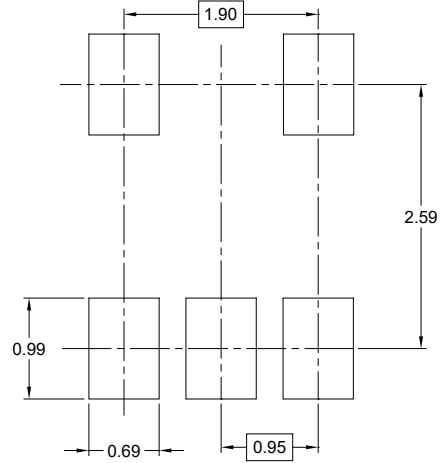
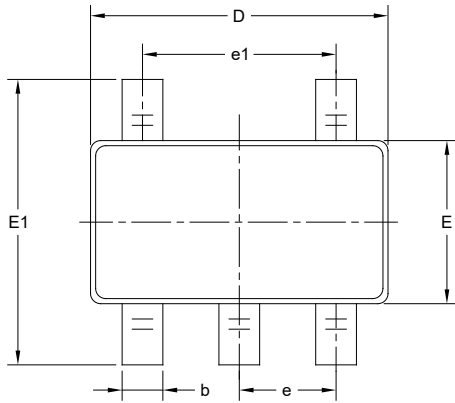

RECOMMENDED LAND PATTERN (Unit: mm)

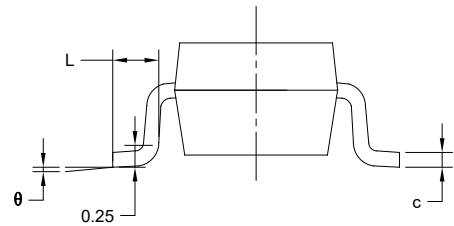
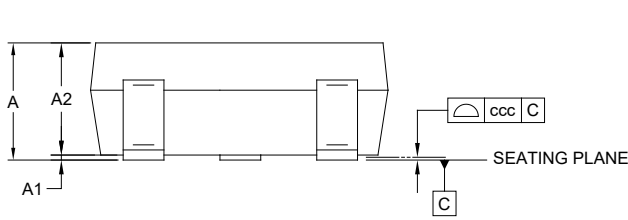

| Symbol   | Dimensions In Millimeters |     |       |
|----------|---------------------------|-----|-------|
|          | MIN                       | MOD | MAX   |
| A        | -                         | -   | 1.450 |
| A1       | 0.000                     | -   | 0.150 |
| A2       | 0.900                     | -   | 1.300 |
| b        | 0.300                     | -   | 0.500 |
| c        | 0.080                     | -   | 0.220 |
| D        | 2.750                     | -   | 3.050 |
| E        | 1.450                     | -   | 1.750 |
| E1       | 2.600                     | -   | 3.000 |
| e        | 0.950 BSC                 |     |       |
| e1       | 1.900 BSC                 |     |       |
| L        | 0.300                     | -   | 0.600 |
| $\theta$ | 0°                        | -   | 8°    |
| ccc      | 0.100                     |     |       |

NOTES:

1. This drawing is subject to change without notice.
2. The dimensions do not include mold flashes, protrusions or gate burrs.
3. Reference JEDEC MO-178.

# PACKAGE INFORMATION

## TAPE AND REEL INFORMATION

### REEL DIMENSIONS

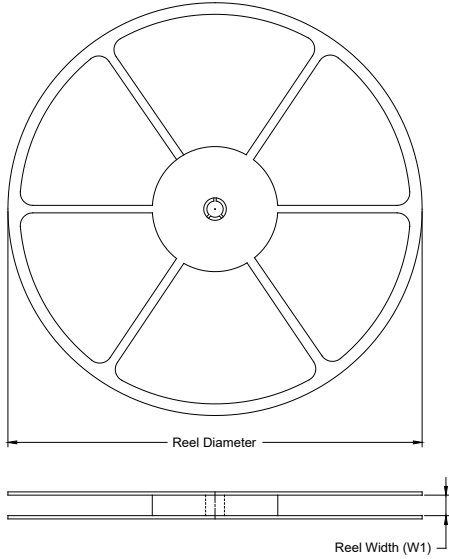

### TAPE DIMENSIONS



NOTE: The picture is only for reference. Please make the object as the standard.

### KEY PARAMETER LIST OF TAPE AND REEL

| Package Type | Reel Diameter | Reel Width W1 (mm) | A0 (mm) | B0 (mm) | K0 (mm) | P0 (mm) | P1 (mm) | P2 (mm) | W (mm) | Pin1 Quadrant |
|--------------|---------------|--------------------|---------|---------|---------|---------|---------|---------|--------|---------------|
| SOT-23-5     | 7"            | 9.5                | 3.20    | 3.20    | 1.40    | 4.0     | 4.0     | 2.0     | 8.0    | Q3            |

000001

# PACKAGE INFORMATION

## CARTON BOX DIMENSIONS



NOTE: The picture is only for reference. Please make the object as the standard.

## KEY PARAMETER LIST OF CARTON BOX

| Reel Type   | Length (mm) | Width (mm) | Height (mm) | Pizza/Carton |
|-------------|-------------|------------|-------------|--------------|
| 7" (Option) | 368         | 227        | 224         | 8            |
| 7"          | 442         | 410        | 224         | 18           |

DD0002