



SGMNQ40430

30V, Power, Single N-Channel, PDFN Package, MOSFET

GENERAL DESCRIPTION

The SGMNQ40430 is a power MOSFET with a low on-state resistance.

FEATURES

- Low On-State Resistance
- Low Total Gate Charge and Capacitance Losses
- Small Footprint (5×6 mm²) for Compact Design
- RoHS Compliant and Halogen Free

APPLICATIONS

- CPU Power Delivery
- DC/DC Converter
- Power Load Switch
- Notebook Battery Management

ABSOLUTE MAXIMUM RATINGS

PARAMETER	SYMBOL	VALUE	UNITS
Drain-to-Source Voltage	V_{DS}	30	V
Gate-to-Source Voltage	V_{GS}	±20	V
Continuous Drain Current (DC)	I_D	90	A
Continuous Drain Current (Pulse)	I_{DM}	170	A
Total Dissipation	P_D	27.7	W
Avalanche Current ⁽¹⁾	I_{AS}	38	A
Avalanche Energy ⁽¹⁾	E_{AS}	72.2	mJ
Junction Temperature	T_J	+150	°C
Storage Temperature Range	T_{STG}	-55 to +150	°C
Lead Temperature (Soldering, 10s)		+260	°C

Stresses beyond those listed in Absolute Maximum Ratings may cause permanent damage to the device. Exposure to absolute maximum rating conditions for extended periods may affect reliability.

NOTE: 1. Parts are 100% tested at $V_{GS} = 10V$, $I_L = 28A$, and $E_{AS} = 39.2mJ$.

PRODUCT SUMMARY

$R_{DS(ON)}$ (TYP)	$R_{DS(ON)}$ (MAX)	I_D (MAX)
2.6mΩ	3.5mΩ	90A

PIN CONFIGURATION

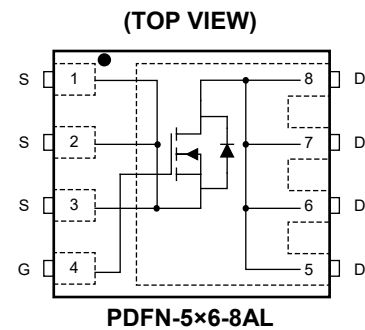

EQUIVALENT CIRCUIT

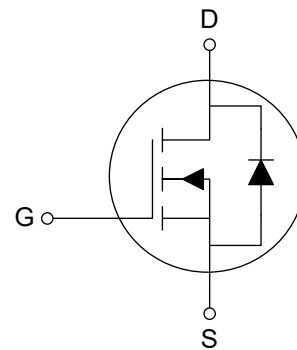

PACKAGE/ORDERING INFORMATION

MODEL	PACKAGE DESCRIPTION	SPECIFIED TEMPERATURE RANGE	ORDERING NUMBER	PACKAGE MARKING	PACKING OPTION
SGMNQ40430	PDFN-5x6-8AL	-55°C to +150°C	SGMNQ40430TPDA8G/TR	SGM40430 TPDA8 XXXXX	Tape and Reel, 4000

MARKING INFORMATION

NOTE: XXXXX = Date Code, Trace Code and Vendor Code.

XXXXX

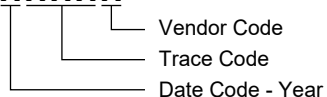

Green (RoHS & HF): SG Micro Corp defines "Green" to mean RoHS Compliant and Halogen Free.

DISCLAIMER

SG Micro Corp reserves the right to make any change in circuit design, or specifications without prior notice.

THERMAL RESISTANCE MAXIMUM RATINGS

PARAMETER	SYMBOL	VALUE	UNITS
Junction-to-Ambient Thermal Resistance	$R_{\theta JA}$	49	°C/W
Junction-to-Case Thermal Resistance	$R_{\theta JC}$	2.1	°C/W

ELECTRICAL CHARACTERISTICS

(T_A = +25°C, unless otherwise noted.)

PARAMETER	SYMBOL	CONDITIONS	MIN	TYP	MAX	UNITS
Static Off Characteristics						
Drain-to-Source Breakdown Voltage	V _{(BR)DSS}	I _D = 250μA, V _{GS} = 0V	30			V
Zero Gate Voltage Drain Current	I _{DSS}	V _{DS} = 24V, V _{GS} = 0V			1	μA
Gate-to-Source Leakage Current	I _{GSS}	V _{GS} = ±20V, V _{DS} = 0V			±100	nA
Static On Characteristics						
Gate-to-Source Threshold Voltage	V _{GS(TH)}	V _{GS} = V _{DS} , I _D = 250μA	1.2	1.6	2.2	V
Drain-to-Source On-State Resistance	R _{DS(ON)}	I _D = 30A, V _{GS} = 10V		2.6	3.5	mΩ
		I _D = 25A, V _{GS} = 4.5V		4.3	6.0	
Forward Transconductance	g _{FS}	V _{DS} = 1.5V, I _D = 15A		41		S
Gate Resistance	R _G	V _{GS} = 0V, V _{DS} = 0V, f = 1MHz		1		Ω
Diode Characteristics						
Diode Forward Voltage	V _{F(SD)}	V _{GS} = 0V, I _S = 10A		0.8	1.1	V
Reverse Recovery Time	t _{RR}	I _S = 30A, V _{GS} = 0V, di/dt = 100A/μs		38.8		ns
Reverse Recovery Charge	Q _{RR}				31.8	
Dynamic Characteristics						
Input Capacitance	C _{ISS}	V _{DS} = 15V, V _{GS} = 0V, f = 1MHz		971		pF
Output Capacitance	C _{OSS}			810		pF
Reverse Transfer Capacitance	C _{RSS}			73		pF
Total Gate Charge	Q _G	V _{DS} = 15V, I _D = 30A	V _{GS} = 10V	20.1		nC
			V _{GS} = 4.5V	9.9		
Gate-to-Source Charge	Q _{GS}	V _{DS} = 15V, V _{GS} = 4.5V, I _D = 30A		3.8		nC
Gate-to-Drain Charge	Q _{GD}			5		nC
Switch Characteristics						
Turn-On Delay Time	t _{D(ON)}	V _{DS} = 15V, V _{GS} = 10V, I _D = 15A, R _G = 3Ω		5.8		ns
Rise Time	t _R			25.6		ns
Turn-Off Delay Time	t _{D(OFF)}			15.5		ns
Fall Time	t _F			4		ns

TYPICAL PERFORMANCE CHARACTERISTICS

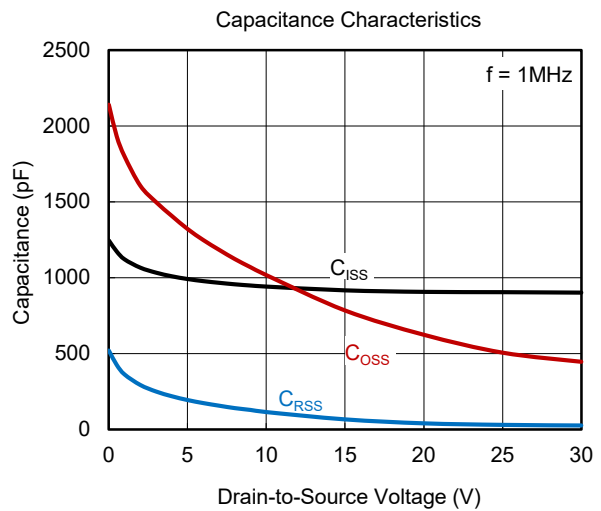
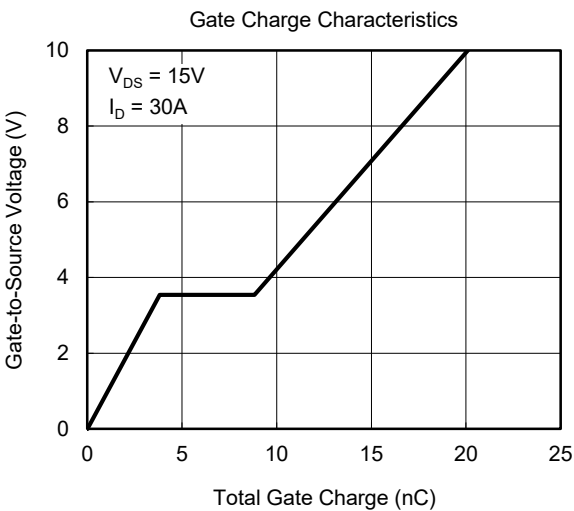
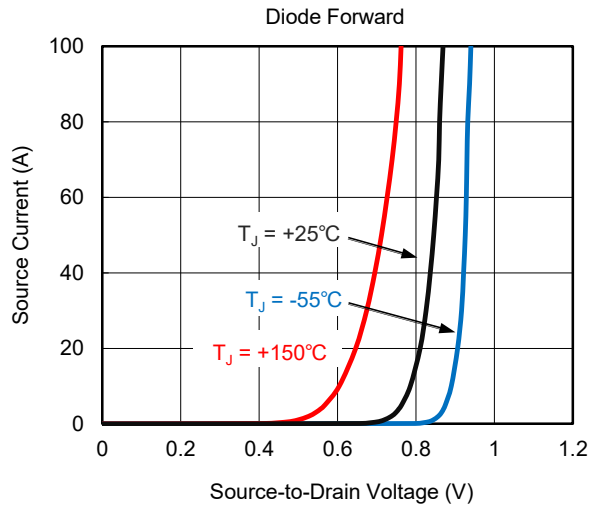
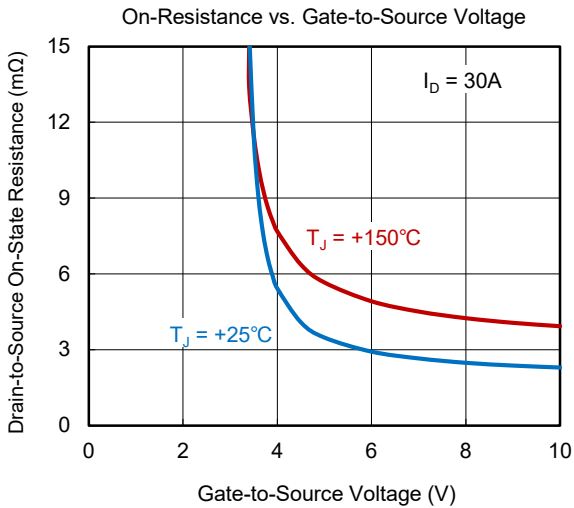
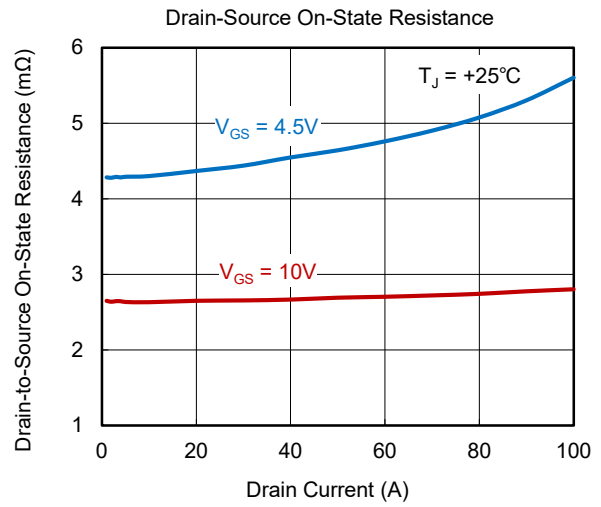
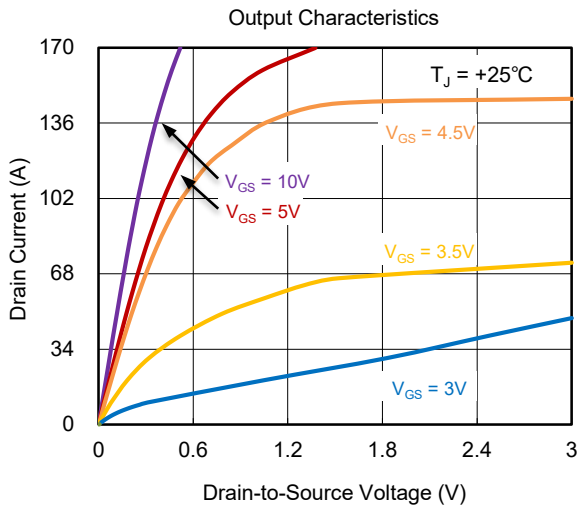

TYPICAL PERFORMANCE CHARACTERISTICS (continued)

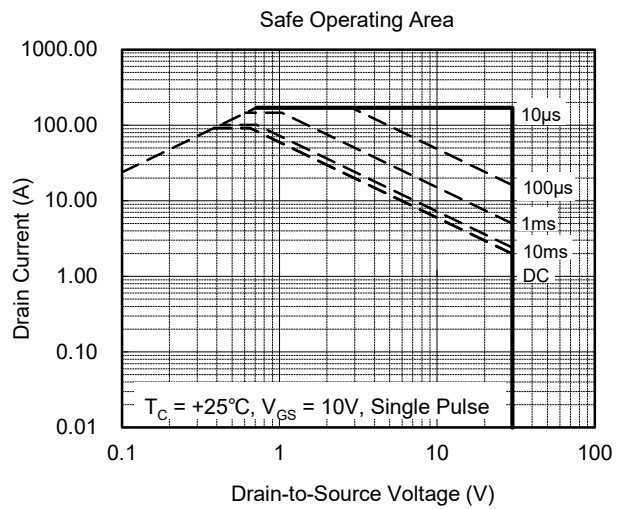
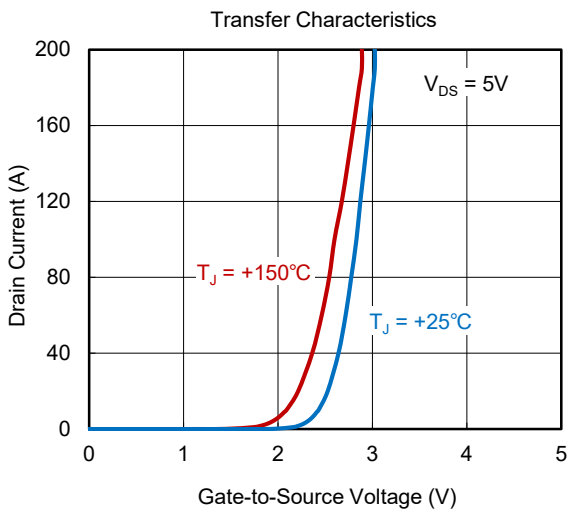
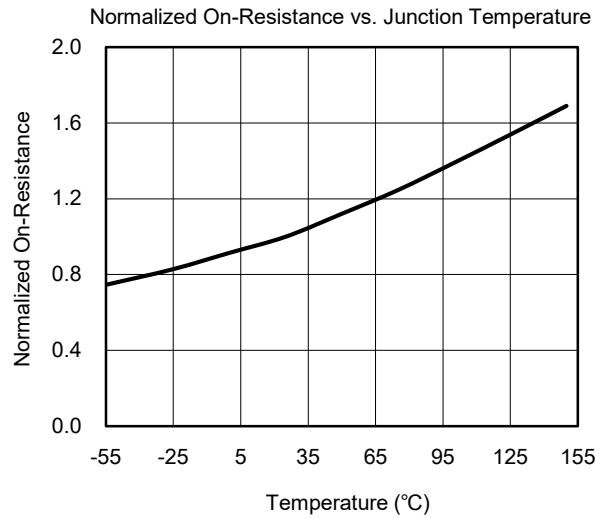
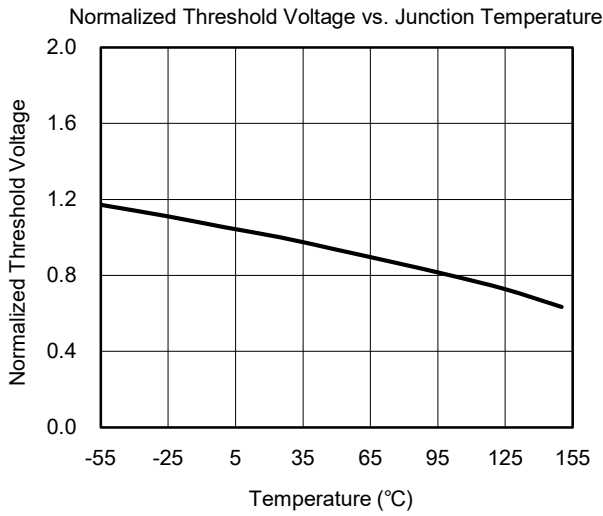

REVISION HISTORY

NOTE: Page numbers for previous revisions may differ from page numbers in the current version.

Changes from Original (OCTOBER 2023) to REV.A

Page

Changed from Product Preview to Production Data All

PACKAGE OUTLINE DIMENSIONS

PDFN-5x6-8AL

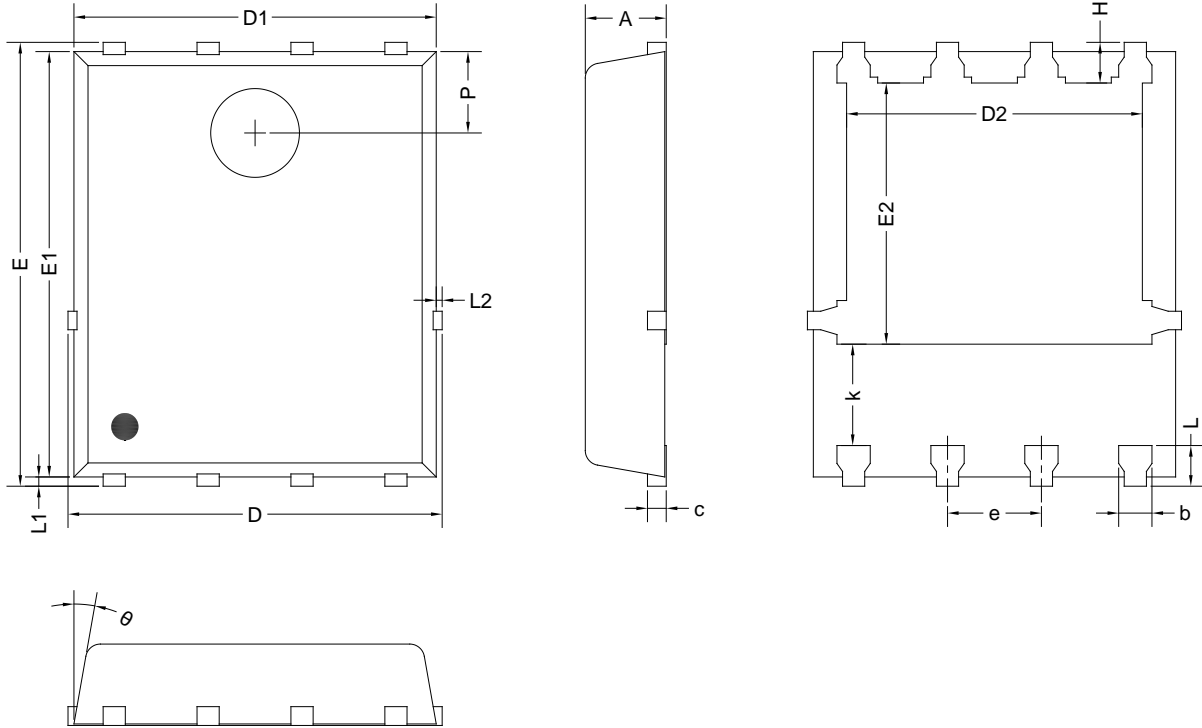

Symbol	Dimensions In Millimeters		
	MIN	MOD	MAX
A	1.000	1.100	1.200
b	0.340	0.450	0.540
c	0.210	0.250	0.340
D	4.800	5.000	5.100
D1	4.800	4.900	5.000
D2	3.900	4.000	4.100
E	5.900	6.000	6.100
E1	5.700	5.750	5.800
E2	3.430	3.530	3.630
e	1.270 BSC		
H	0.450	0.550	0.650
k	1.170	1.370	1.570
L	0.450	0.550	0.650
L1	0.000	0.130	0.200
L2	0.000	0.080	0.150
P	1.000	1.100	1.200
θ	8°	10°	12°

NOTE: This drawing is subject to change without notice.

TAPE AND REEL INFORMATION

REEL DIMENSIONS



TAPE DIMENSIONS



NOTE: The picture is only for reference. Please make the object as the standard.

KEY PARAMETER LIST OF TAPE AND REEL

Package Type	Reel Diameter	Reel Width W1 (mm)	A0 (mm)	B0 (mm)	K0 (mm)	P0 (mm)	P1 (mm)	P2 (mm)	W (mm)	Pin1 Quadrant
PDFN-5×6-8AL	13"	12.4	6.45	5.30	1.40	4.0	8.0	2.0	12.0	Q1

DD0001

PACKAGE INFORMATION

CARTON BOX DIMENSIONS



NOTE: The picture is only for reference. Please make the object as the standard.

KEY PARAMETER LIST OF CARTON BOX

Reel Type	Length (mm)	Width (mm)	Height (mm)	Pizza/Carton
13"	386	280	370	5

DD0002