

GENERAL DESCRIPTION

The SGM2593A and SGM2593AD are single channel power distribution switches. The switch controlled by the EN pin operates from 2.5V to 6V supply voltage. It can be used in USB power distribution applications.

The device has integrated programmable current limit function to protect the upstream power supply from damage during over-current or short-circuit condition. It also has the function of over-temperature protection.

The device is designed with soft-start circuit to cope with inrush currents when large capacitive loads are connected. The nFAULT output will be asserted to low level during over-current, over-temperature or reverse voltage condition.

The SGM2593AD further reduces the total solution size by integrating a 50Ω pull-down resistor for output discharge when the switch is shut down by EN.

The SGM2593A and SGM2593AD are available in Green TDFN-2×2-6AL and SOT-23-6 packages.

APPLICATIONS

- General Purpose Power Switching
- USB Bus/Self-Powered Hub
- USB Peripheral
- ACPI Power Distribution
- Smart Phone
- LCD TV

FEATURES

- High-side N-MOSFET
- On-Resistance:
 - ♦ TDFN-2×2-6AL: 60mΩ (TYP)
 - ♦ SOT-23-6: 65mΩ (TYP)
- Programmable Current Limit Range:
 - ♦ 0.1A to 3A
- Input Voltage Range: 2.5V to 6V
- Quiescent Current: 28μA (TYP)
- Shutdown Current: 0.3μA (TYP)
- Soft-Start Function
- Over-Temperature Protection
- Under-Voltage Lockout Protection for VIN
- No Reversed Leakage Current (Reverse Blocking)
- Fault Flag (nFAULT Pin)
- Quick Output Discharge
- 1.2MΩ Pull-Down Resistor at EN Pin
- Available in a Green TDFN-2×2-6AL and SOT-23-6 Packages

TYPICAL APPLICATION

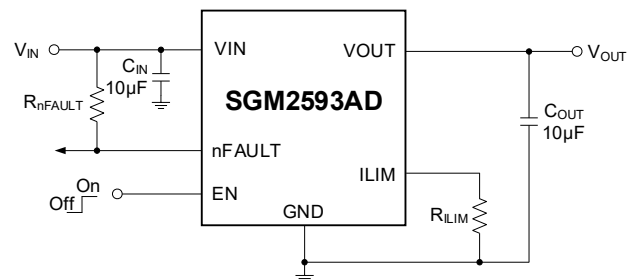

Figure 1. Typical Application Circuit

PACKAGE/ORDERING INFORMATION

MODEL	PACKAGE DESCRIPTION	SPECIFIED TEMPERATURE RANGE	ORDERING NUMBER	PACKAGE MARKING	PACKING OPTION
SGM2593A	TDFN-2x2-6AL	-40°C to +125°C	SGM2593AXTDI6G/TR	0RU XXXX	Tape and Reel, 3000
	SOT-23-6	-40°C to +125°C	SGM2593AXN6G/TR	0RVXX	Tape and Reel, 3000
SGM2593AD	TDFN-2x2-6AL	-40°C to +125°C	SGM2593ADXTDI6G/TR	0RS XXXX	Tape and Reel, 3000
	SOT-23-6	-40°C to +125°C	SGM2593ADNXN6G/TR	0RTXX	Tape and Reel, 3000

MARKING INFORMATION

NOTE: XXXX = Date Code, Trace Code and Vendor Code. XX = Date Code.

TDFN-2x2-6AL

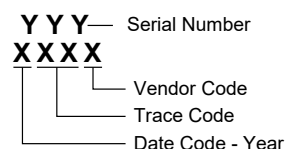

SOT-23-6

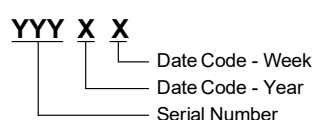

Green (RoHS & HSF): SG Micro Corp defines "Green" to mean Pb-Free (RoHS compatible) and free of halogen substances. If you have additional comments or questions, please contact your SGMICRO representative directly.

ABSOLUTE MAXIMUM RATINGS

VIN.....	6.5V
All Other Pins.....	6V
Package Thermal Resistance	
TDFN-2x2-6AL, θ_{JA}	65.1°C/W
TDFN-2x2-6AL, θ_{JB}	32°C/W
TDFN-2x2-6AL, $\theta_{JC (TOP)}$	84.8°C/W
TDFN-2x2-6AL, $\theta_{JC (BOT)}$	13.4°C/W
SOT-23-6, θ_{JA}	173°C/W
SOT-23-6, θ_{JB}	39.2°C/W
SOT-23-6, θ_{JC}	93.4°C/W
Junction Temperature.....	+150°C
Storage Temperature Range	-65°C to +150°C
Lead Temperature (Soldering, 10s).....	+260°C
ESD Susceptibility	
HBM.....	2000V
CDM	1000V

RECOMMENDED OPERATING CONDITIONS

Input Voltage Range	2.5V to 6V
EN Voltage Range	-0.3V to 5.5V
All Other Pins.....	0V to 5.5V
Operating Junction Temperature Range.....	-40°C to +125°C

OVERSTRESS CAUTION

Stresses beyond those listed in Absolute Maximum Ratings may cause permanent damage to the device. Exposure to absolute maximum rating conditions for extended periods may affect reliability. Functional operation of the device at any conditions beyond those indicated in the Recommended Operating Conditions section is not implied.

ESD SENSITIVITY CAUTION

This integrated circuit can be damaged if ESD protections are not considered carefully. SGMICRO recommends that all integrated circuits be handled with appropriate precautions. Failure to observe proper handling and installation procedures can cause damage. ESD damage can range from subtle performance degradation to complete device failure. Precision integrated circuits may be more susceptible to damage because even small parametric changes could cause the device not to meet the published specifications.

DISCLAIMER

SG Micro Corp reserves the right to make any change in circuit design, or specifications without prior notice.

PIN CONFIGURATIONS

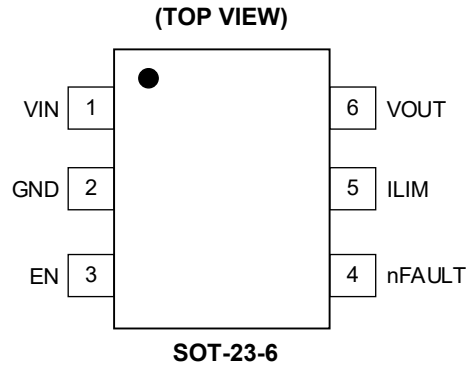
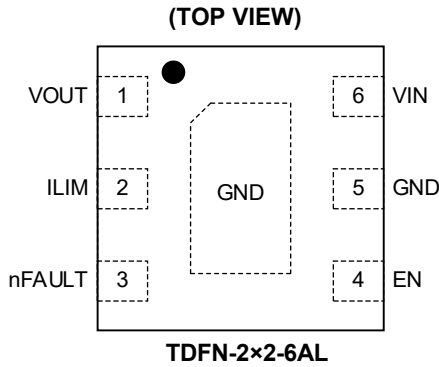

PIN DESCRIPTION

PIN		NAME	FUNCTION
TDFN-2x2-6AL	SOT-23-6		
1	6	VOUT	Output Voltage.
2	5	ILIM	Current Limit Programming Pin. Connect a resistor R_{ILIM} from this pin to GND to set the overload current limit threshold: $I_{LIM}(mA) = \frac{24114V}{R_{ILIM}^{0.977}k\Omega}$ If the ILIM pin is connected to GND directly, the current limit function is not available.
3	4	nFAULT	Active-Low Open-Drain Output. It is asserted during over-current, over-temperature or reverse voltage condition.
4	3	EN	Chip Enable. Active-high for SGM2593AD/SGM2593A. It has integrated a 1.2M Ω pull-down resistor at this pin.
5	2	GND	Ground.
6	1	VIN	Power Input Voltage.
Exposed Pad	-	GND	Device Ground. The exposed pad must be connected to ground.

ELECTRICAL CHARACTERISTICS

(T_J = -40°C to +125°C, typical values are at T_J = +25°C, V_{IN} = 5V, unless otherwise noted.)

PARAMETER	SYMBOL	CONDITIONS	MIN	TYP	MAX	UNITS	
Input Voltage Range	V _{IN}		2.5		6	V	
Under-Voltage Lockout Threshold	V _{UVLO}	V _{IN} rising		2.23	2.4	V	
	V _{UVLO_HYS}	V _{IN} falling		100		mV	
Quiescent Current	I _Q	Switch on, V _{OUT} = open		28	60	μA	
Shutdown Current	I _{SD}	Switch off, V _{OUT} = open		0.3	3	μA	
Output Leakage Current (SGM2593A Only)	I _{LEAKAGE}	Switch off, V _{OUT} = 6V, V _{IN} = 0V, T _J = -40°C to +85°C		0.2	1.5	μA	
		Switch off, V _{OUT} = 6V, V _{IN} = 0V, T _J = -40°C to +125°C		0.2	6		
Enable Input Threshold	V _{IH}		1.2			V	
	V _{IL}	T _J = -40°C to +85°C			0.4		
		T _J = -40°C to +125°C			0.3		
Pull-Down Resistor at EN Pin	R _{PULL_DOWN}			1.2		MΩ	
On-Resistance	R _{DSON}	I _{OUT} = 200mA	TDFN-2x2-6AL		60	100	mΩ
			SOT-23-6				
			T _J = -40°C to +85°C	65	98	mΩ	
			T _J = -40°C to +125°C	65	125		
Output Turn-On Delay Time	t _{ON}	R _L = 100Ω, C _{OUT} = 0.1μF		1		ms	
Output Turn-Off Delay Time	t _{OFF}	R _L = 100Ω, C _{OUT} = 0.1μF	SGM2593A	32		μs	
			SGM2593AD	27			
Output Turn-On Rise Time	t _R	R _L = 100Ω, C _{OUT} = 0.1μF		1.3		ms	
Output Turn-Off Fall Time	t _F	R _L = 100Ω, C _{OUT} = 0.1μF	SGM2593A	27		μs	
			SGM2593AD	13			
Over-Current nFAULT Response Delay Time	t _D	Force the chip into current limit mode		15		ms	
Current Limit Threshold	I _{LIM}	R _{LIM} = 8.2kΩ, T _J = +25°C	2865	3070	3270	mA	
		R _{LIM} = 8.2kΩ, T _J = -40°C to +125°C	2830	3070	3295		
		R _{LIM} = 10.2kΩ, T _J = +25°C	2320	2485	2655		
		R _{LIM} = 10.2kΩ, T _J = -40°C to +125°C	2280	2485	2675		
		R _{LIM} = 15kΩ, T _J = +25°C	1600	1715	1830		
		R _{LIM} = 15kΩ, T _J = -40°C to +125°C	1570	1715	1845		
		R _{LIM} = 17kΩ, T _J = +25°C	1420	1520	1620		
		R _{LIM} = 17kΩ, T _J = -40°C to +125°C	1395	1520	1635		
		R _{LIM} = 20kΩ, T _J = +25°C	1220	1300	1375		
		R _{LIM} = 20kΩ, T _J = -40°C to +125°C	1200	1300	1385		
		R _{LIM} = 50kΩ, T _J = +25°C	475	520	565		
		R _{LIM} = 50kΩ, T _J = -40°C to +125°C	470	520	565		
		R _{LIM} = 210kΩ, T _J = +25°C	95	130	170		
		R _{LIM} = 210kΩ, T _J = -40°C to +125°C	90	130	175		
Reverse Protection Threshold	V _{REV}	V _{OUT} rising	5	25	42	mV	
Reverse Protection Threshold Hysteresis	V _{REV_HYS}	V _{OUT} falling		15		mV	
nFAULT Output Resistance	R _{nFAULT}	nFAULT is low and I _{SINK} = 10mA		22		Ω	
nFAULT Leakage Current	I _{nFAULT}	nFAULT is high		4		nA	
V _{OUT} Shutdown Discharge Resistance (SGM2593AD Only)	R _{DIS}	Switch off, sink 2mA into OUT		50		Ω	
Thermal Shutdown Temperature	T _{SD}	T _J increasing		156		°C	
Thermal Shutdown Hysteresis	T _{HYS}			30		°C	

NOTE: The reverse nFAULT response delay time is 0.2ms.

TYPICAL PERFORMANCE CHARACTERISTICS

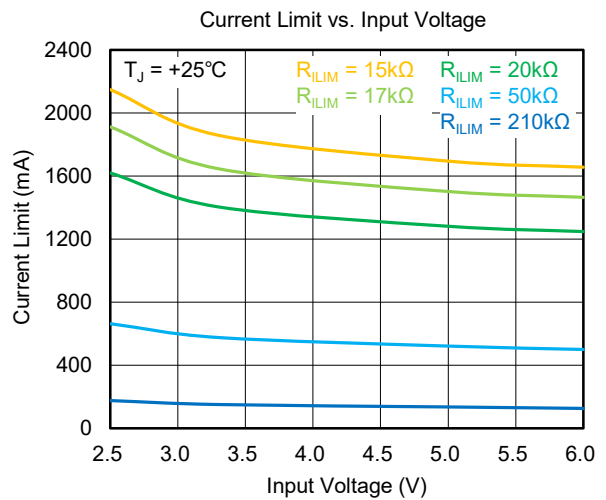
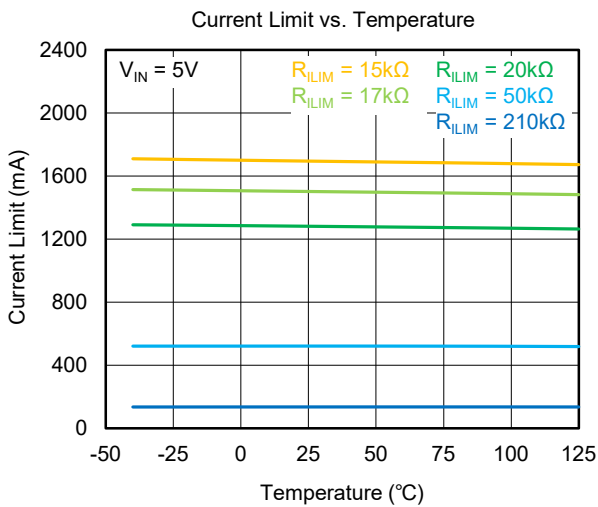
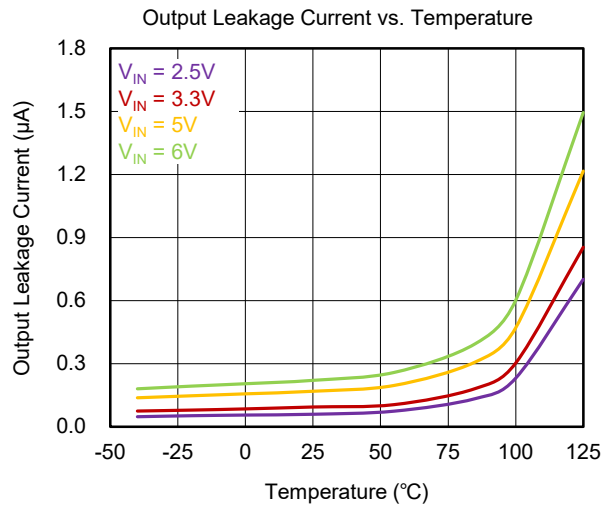
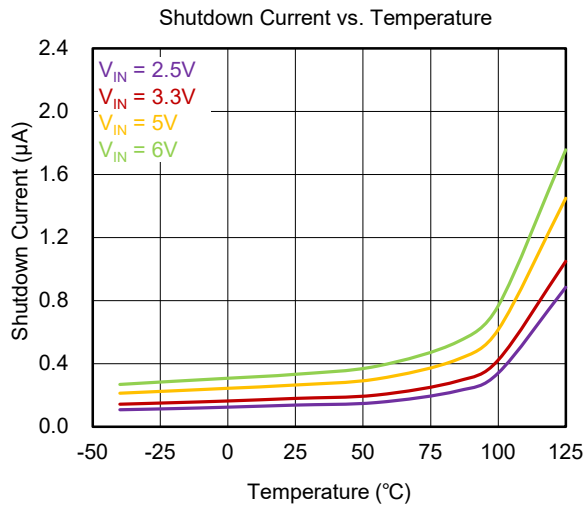
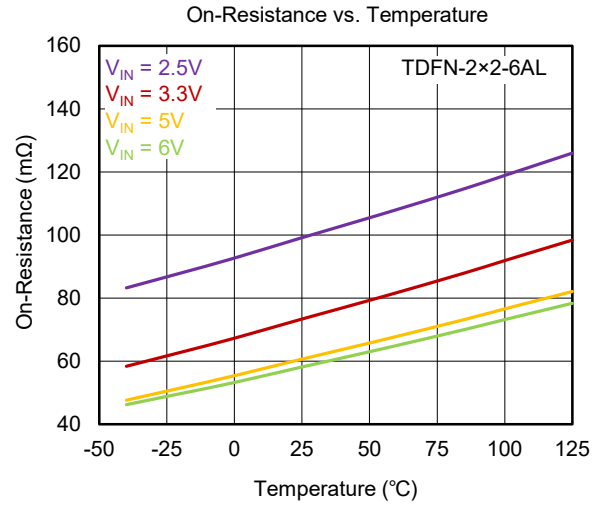
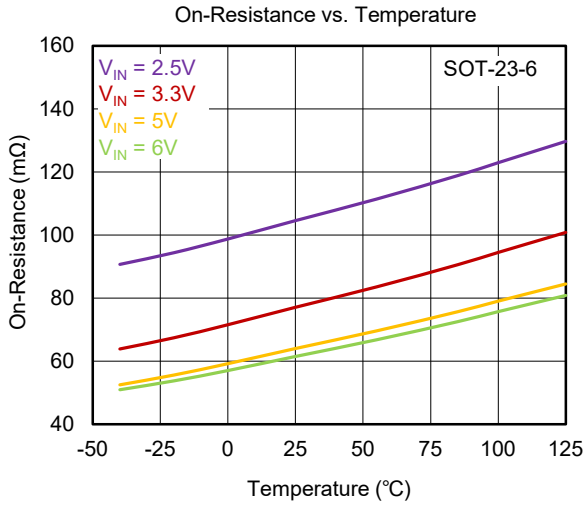

TYPICAL PERFORMANCE CHARACTERISTICS (continued)

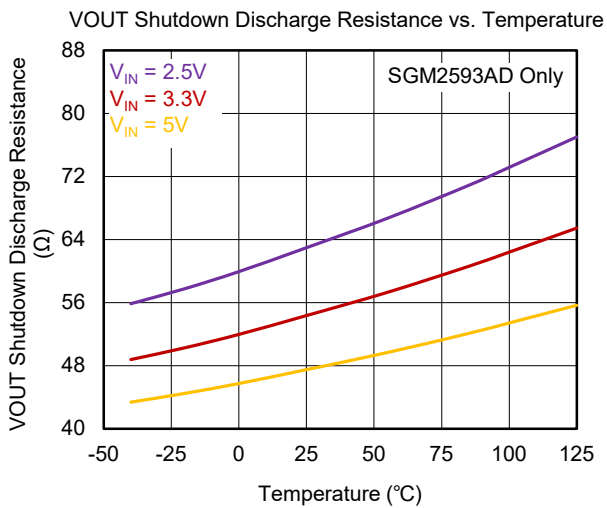
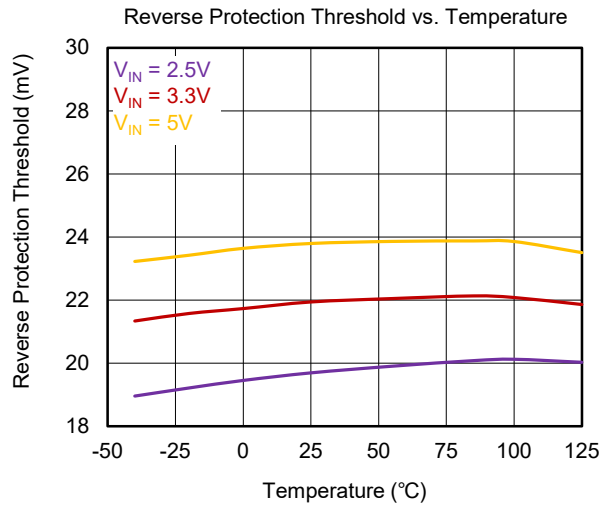
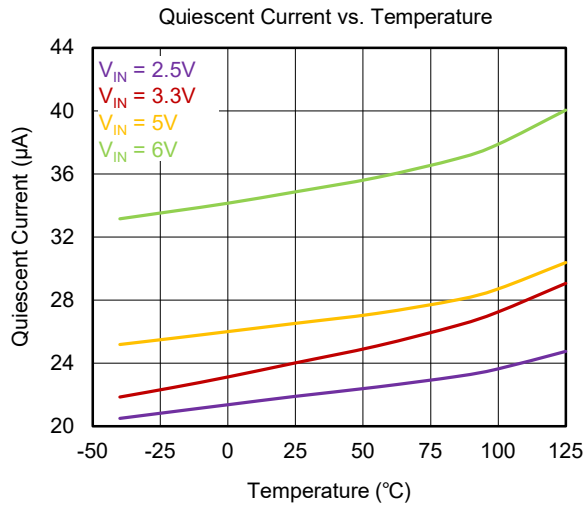

TYPICAL PERFORMANCE CHARACTERISTICS (continued)

Turn-On Delay and Rise Time

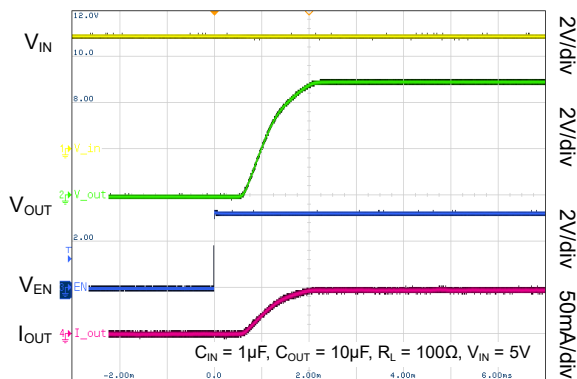

Time (1ms/div)

Turn-Off Delay and Fall Time

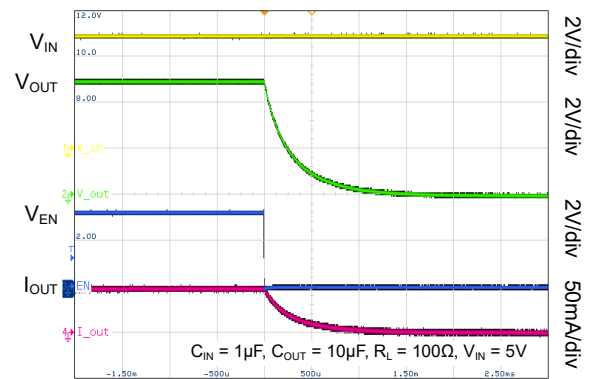

Time (500µs/div)

No Load to Output Short Transient Response

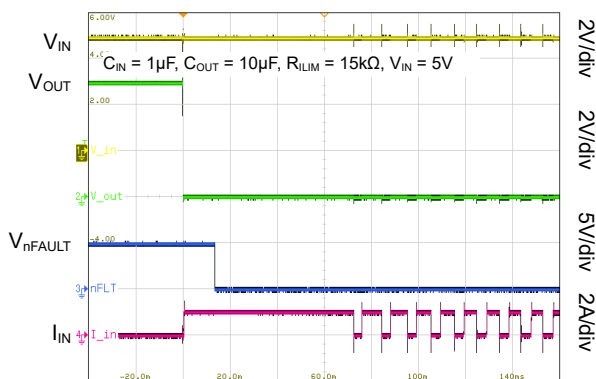

Time (20ms/div)

Output Short to No Load Recovery Response

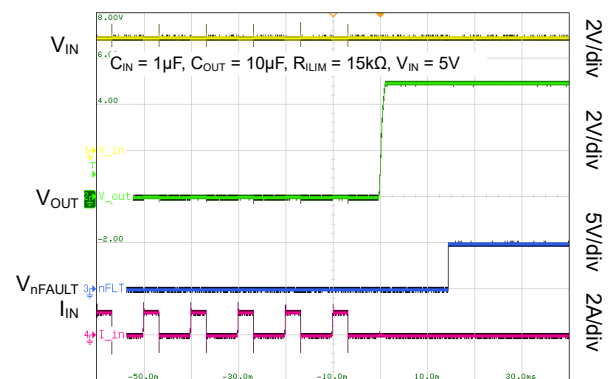

Time (10ms/div)

FUNCTIONAL BLOCK DIAGRAM

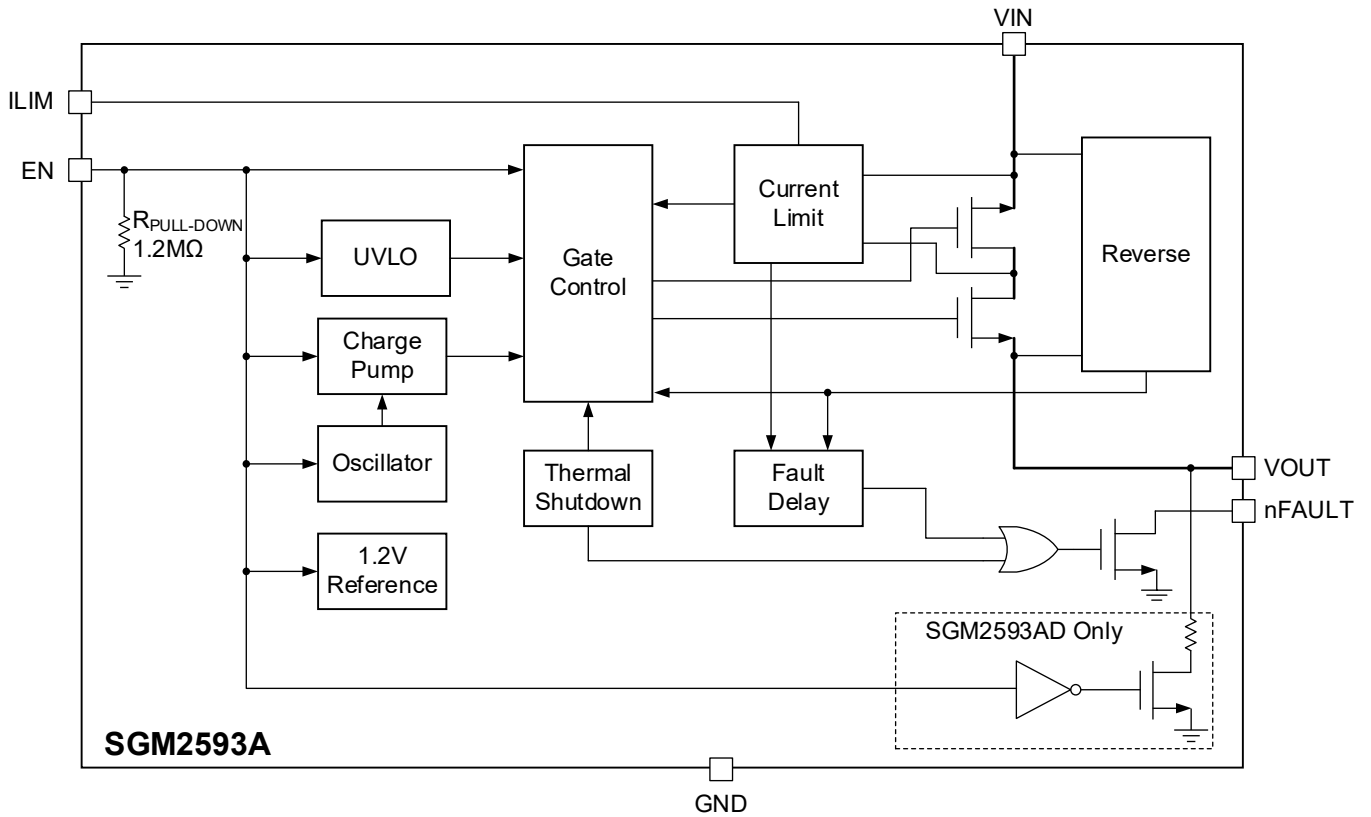

Figure 2. Block Diagram

TIMING DIAGRAMS

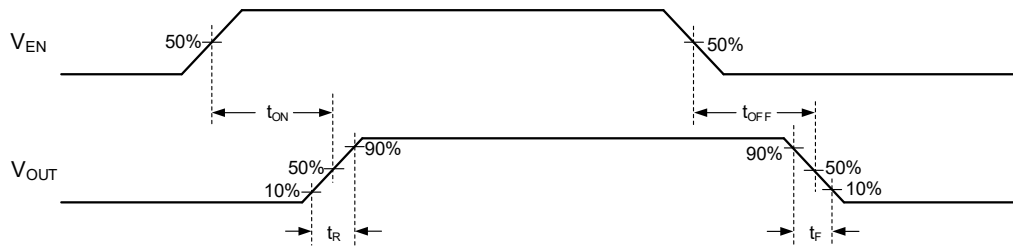

Figure 3. Switch Turn-On and Turn-Off Times

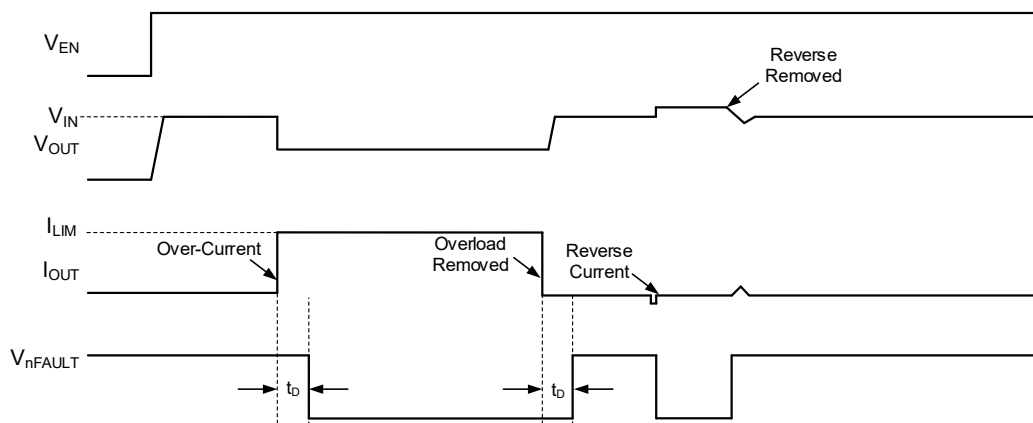

Figure 4. Fault Timing: Output Reset by Toggling EN

DETAILED DESCRIPTION

Input and Output

VIN should be connected to the power source that is the power supply of the internal logic circuitry and loads. Normally, load current flows from VIN to VOUT. The output MOSFET and driver circuit are designed to allow the voltage of VOUT is higher than VIN, when the device is turned off.

Thermal Shutdown (TSD)

The thermal shutdown threshold is +156°C with 30°C hysteresis.

Soft-Start

The soft-start feature is used to limit inrush current during startup or hot-plug events so that the device can cope with inrush current when connected to large capacitive loads.

Under-Voltage Lockout (UVLO)

If the voltage on VIN pin falls below its under-voltage lockout threshold, the device will be disabled. The device resumes operation when the power supply goes back above UVLO threshold.

Current Limit and Short-Circuit Protection

The current limit protection circuit is designed to protect the upstream power supply by limiting the output current to the current limit threshold set by the R_{ILIM} from ILIM to GND.

The current limit threshold is 40% discount of I_{LIM} in short-circuit state and the nFAULT pin will be asserted after the device enters short-circuit state for t_D (15ms).

If the short-circuit state persists, the device will cycle on and off under thermal protection as a result of power dissipation.

Fault Flag (nFAULT)

The device is designed to achieve delayed response via the internal delay "deglitch" circuit for over-current ($t_D = 15ms$, TYP) condition. The nFAULT pin indicates that the device enters and leaves over-current condition after the delay time (t_D). But nFAULT will be asserted to low level as soon as the over-temperature condition occurs.

The nFAULT is the structure of N-MOSFET open-drain that outputs low level when an over-current, over-temperature or reverse voltage condition occurs. Figure 4 depicts the typical timing.

When an over-current occurs, nFAULT will not be asserted until the over-current persists for a delay time (t_D). This ensures that nFAULT will not be asserted due to disturbances such as current jitter, thus avoids false fault reports.

Reverse Voltage Protection

When the output voltage exceeds the input voltage by 25mV (TYP), the device turns off the internal N-MOSFET to avoid the reverse current from the output to input. Its hysteresis voltage is 15mV (TYP).

Output Discharge

The SGM2593AD integrates the output discharge feature. When the EN pin is pulled low (below V_{IL}), a discharge resistance with a typical value of 50Ω is connected between the VOUT and GND. This resistance pulls down the output and prevents it from floating when the device is disabled.

APPLICATION INFORMATION

Current Limit Programming

An external resistor (R_{ILIM}) placed between the ILIM pin and GND sets the switch current limit threshold (I_{LIM}). The ILIM pin voltage is regulated by an internal control loop. The current limit threshold is proportional to the current pulled from the ILIM pin by the resistor. Use short trace routes for the R_{ILIM} on the PCB to minimize the impact of parasitics and noise on the accuracy of the current limit setting.

$$I_{LIM}(mA) = \frac{24114V}{R_{ILIM}^{0.977}k\Omega} \tag{1}$$

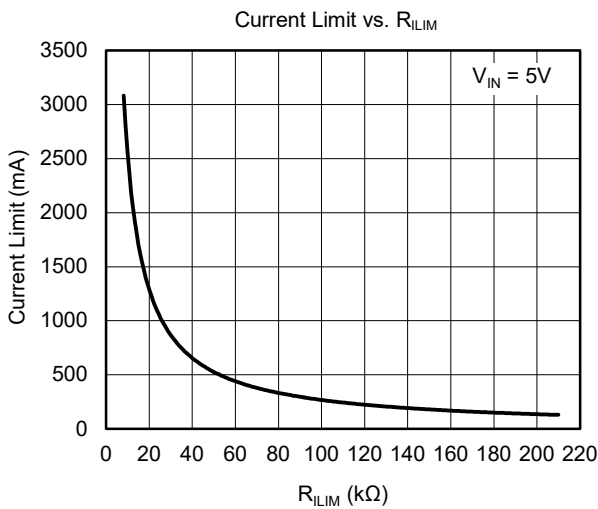

Figure 5. Current Limit Threshold (I_{LIM}) vs. Current Limit Programming Resistor (R_{ILIM})

Power Dissipation

Assuming a given ambient temperature and an output current, the maximum allowable power dissipation is calculated by:

$$P_{D(MAX)} = \frac{T_{J(MAX)} - T_A}{\theta_{JA}} \tag{2}$$

where:

- ♦ $P_{D(MAX)}$ is the maximum power dissipation.
- ♦ $T_{J(MAX)}$ is the maximum operating junction temperature.
- ♦ T_A is the operating ambient temperature.
- ♦ θ_{JA} is junction to air thermal impedance.

REVISION HISTORY

NOTE: Page numbers for previous revisions may differ from page numbers in the current version.

Changes from Original (JUNE 2024) to REV.A	Page
Changed from product preview to production data.....	All

Please note that the thermal vias are placed under the exposed pad of the device, thus allowing for thermal dissipation away from the device.

Supply Filter Capacitor

It is recommended to use a 10μF capacitor between VIN and GND close to the device pins. It can limit the voltage drop of the input supply. Larger C_{IN} can reduce voltage dip in high current applications. Without an input capacitor, short-circuit at the output will cause the input voltage to ring, which may destroy the chip's internal circuitry when the input transient voltage exceeds the absolute maximum supply voltage (6.5V).

Output Filter Capacitor

It is recommended to use a low-ESR 10μF ceramic capacitor between VOUT and GND standard bypass methods to reduce EMI, improve the transient performance, and minimize negative effects of resistance and inductance between the bypass capacitor and the downstream connector. If the output port is connected to the load through a long cable, the parasitic inductance of the cable may cause voltage to ring, whose negative ringing may damage the chip, so an anti-parallel Schottky diode such as BAT54 is recommended to connect in parallel with the output.

PCB Layout Guidelines

A reasonable PCB layout is critical to the stable performance of the device. For best results, follow the guidelines below.

- ♦ Keep the power traces as short and wide as possible, and use at least 2 ounces of copper.
- ♦ Placing a ground plane under all circuits to reduce resistance and inductance will improve DC and transient performances.
- ♦ Ensure that the input decoupling capacitors on VIN have a minimal trace length to VIN and GND.
- ♦ Place the output capacitors as close to the device as possible to minimize the effect of PCB parasitic inductance.

PACKAGE OUTLINE DIMENSIONS

TDFN-2x2-6AL

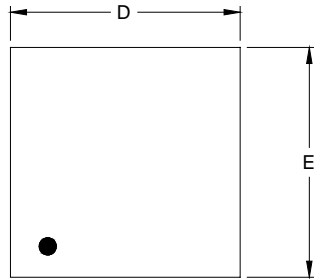

TOP VIEW

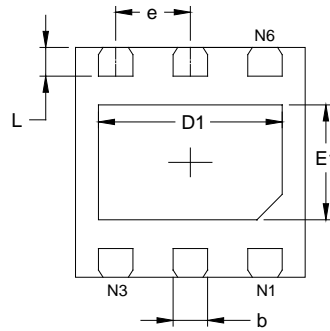

BOTTOM VIEW

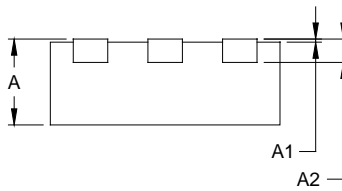

SIDE VIEW

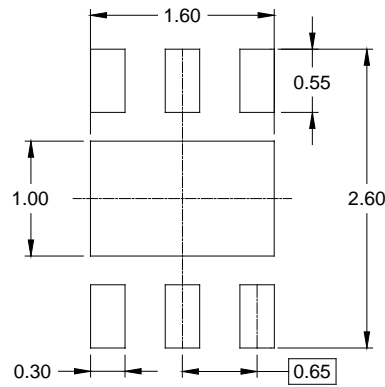

RECOMMENDED LAND PATTERN (Unit: mm)

Symbol	Dimensions In Millimeters		Dimensions In Inches	
	MIN	MAX	MIN	MAX
A	0.700	0.800	0.028	0.031
A1	0.000	0.050	0.000	0.002
A2	0.203 REF		0.008 REF	
D	1.900	2.100	0.075	0.083
D1	1.500	1.700	0.059	0.067
E	1.900	2.100	0.075	0.083
E1	0.900	1.100	0.035	0.043
b	0.250	0.350	0.010	0.014
e	0.650 BSC		0.026 BSC	
L	0.174	0.326	0.007	0.013

NOTE: This drawing is subject to change without notice.

PACKAGE OUTLINE DIMENSIONS

SOT-23-6

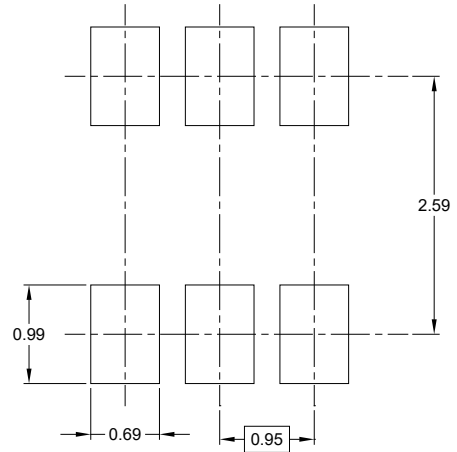
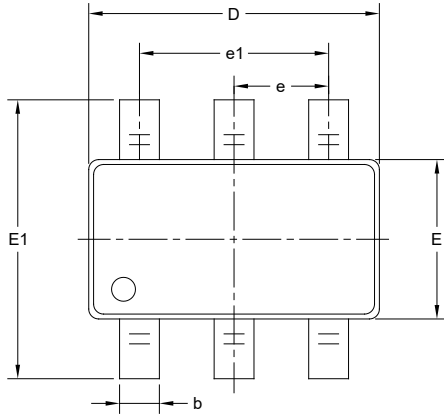

RECOMMENDED LAND PATTERN (Unit: mm)

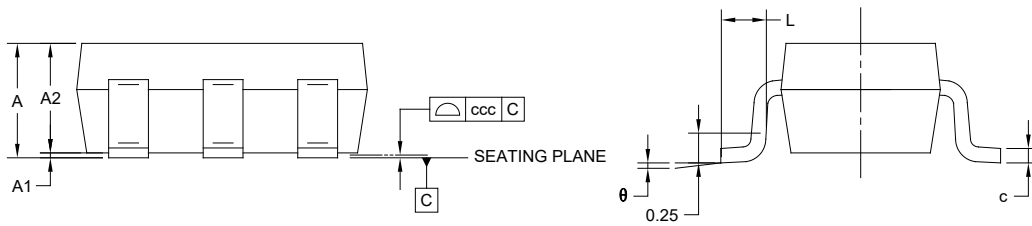

Symbol	Dimensions In Millimeters		
	MIN	MOD	MAX
A	-	-	1.450
A1	0.000	-	0.150
A2	0.900	-	1.300
b	0.300	-	0.500
c	0.080	-	0.220
D	2.750	-	3.050
E	1.450	-	1.750
E1	2.600	-	3.000
e	0.950 BSC		
e1	1.900 BSC		
L	0.300	-	0.600
θ	0°	-	8°
ccc	0.100		

NOTES:

1. This drawing is subject to change without notice.
2. The dimensions do not include mold flashes, protrusions or gate burrs.
3. Reference JEDEC MO-178.

TAPE AND REEL INFORMATION

REEL DIMENSIONS



TAPE DIMENSIONS



NOTE: The picture is only for reference. Please make the object as the standard.

KEY PARAMETER LIST OF TAPE AND REEL

Package Type	Reel Diameter	Reel Width W1 (mm)	A0 (mm)	B0 (mm)	K0 (mm)	P0 (mm)	P1 (mm)	P2 (mm)	W (mm)	Pin1 Quadrant
TDFN-2×2-6AL	7"	9.5	2.30	2.30	1.10	4.0	4.0	2.0	8.0	Q2
SOT-23-6	7"	9.5	3.23	3.17	1.37	4.0	4.0	2.0	8.0	Q3

000001

PACKAGE INFORMATION

CARTON BOX DIMENSIONS



NOTE: The picture is only for reference. Please make the object as the standard.

KEY PARAMETER LIST OF CARTON BOX

Reel Type	Length (mm)	Width (mm)	Height (mm)	Pizza/Carton
7" (Option)	368	227	224	8
7"	442	410	224	18

DD0002