

GENERAL DESCRIPTION

The SGM4565 is a SIM card interface level translator between host controller and SIM card. It provides the high-speed level shifting function between host's 1.08V to 1.98V logic level and SIM card's 1.62V to 3.6V logic level. The signals include Data, CLK and Reset.

The SGM4565 is available in a Green UTQFN-1.8×1.4-10L package.

APPLICATIONS

- Smart Phone
- SIM Card Terminals
- POS Machine

FEATURES

- Support 1.62V to 3.6V SIM Card Supply Voltage
- Support 1.08V to 1.98V Host Microcontroller Supply Voltage
- Support up to 10MHz Clock Frequency
- Automatic Level Translation of Data, Reset and CLK Signals between Host and SIM Card
- Support Automatic Enable and Disable by V_{CCB}
- Integrated Pull-Up and Pull-Down Resistors
- Integrated EMI Filters
- Available in a Green UTQFN-1.8×1.4-10L Package

TYPICAL APPLICATION

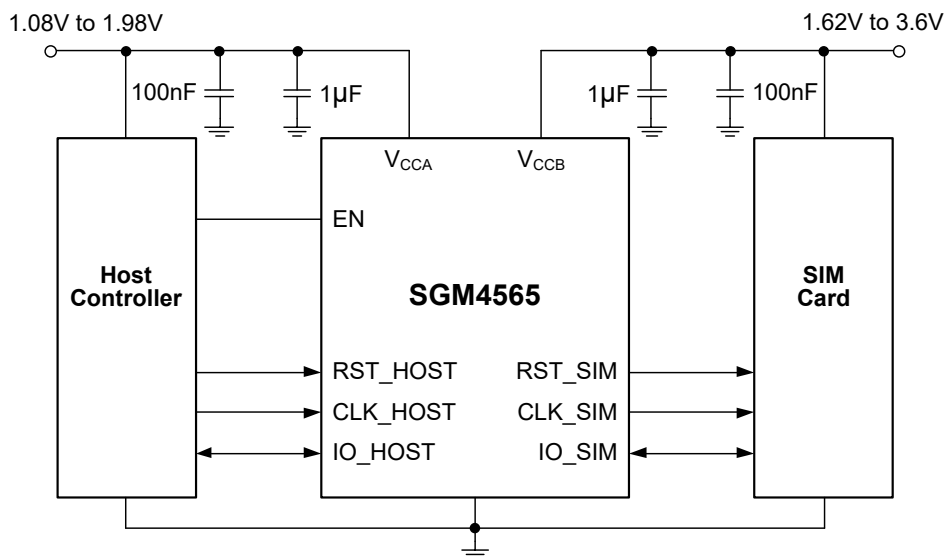

Figure 1. Typical Application Circuit

PACKAGE/ORDERING INFORMATION

MODEL	PACKAGE DESCRIPTION	SPECIFIED TEMPERATURE RANGE	ORDERING NUMBER	PACKAGE MARKING	PACKING OPTION
SGM4565	UTQFN-1.8×1.4-10L	-40°C to +125°C	SGM4565XUWQ10G/TR	07F XXX	Tape and Reel, 3000

MARKING INFORMATION

NOTE: XXX = Date Code and Trace Code.

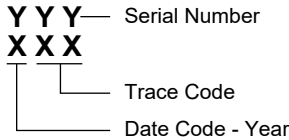

Green (RoHS & HSF): SG Micro Corp defines "Green" to mean Pb-Free (RoHS compatible) and free of halogen substances. If you have additional comments or questions, please contact your SGMICRO representative directly.

ABSOLUTE MAXIMUM RATINGS

- Supply Voltage Range
 - Host Supply, V_{CCA} -0.5V to 4.6V
 - SIM Supply, V_{CCB} -0.5V to 4.6V
- Input/Output Voltage Range (Host Side)
 - CLK_HOST, $V_{I(CLK_HOST)}$ -0.5V to MIN (4.6V, $V_{CCA} + 0.3V$)
 - RST_HOST, $V_{I(RST_HOST)}$ -0.5V to MIN (4.6V, $V_{CCA} + 0.3V$)
 - IO_HOST, $V_{I(IO_HOST)}$ -0.5V to MIN (4.6V, $V_{CCA} + 0.3V$)
 - EN, $V_{I(EN)}$ -0.5V to 4.6V
- Input/Output Voltage Range (SIM Side)
 - CLK_SIM, $V_{I(CLK_SIM)}$ -0.5V to MIN (4.6V, $V_{CCB} + 0.3V$)
 - RST_SIM, $V_{I(RST_SIM)}$ -0.5V to MIN (4.6V, $V_{CCB} + 0.3V$)
 - IO_SIM, $V_{I(IO_SIM)}$ -0.5V to MIN (4.6V, $V_{CCB} + 0.3V$)
- Junction Temperature +150°C
- Storage Temperature Range -65°C to +150°C
- Lead Temperature (Soldering, 10s) +260°C
- ESD Susceptibility
 - HBM 8000V
 - CDM 1000V

OVERSTRESS CAUTION

Stresses beyond those listed in Absolute Maximum Ratings may cause permanent damage to the device. Exposure to absolute maximum rating conditions for extended periods may affect reliability. Functional operation of the device at any conditions beyond those indicated in the Recommended Operating Conditions section is not implied.

ESD SENSITIVITY CAUTION

This integrated circuit can be damaged if ESD protections are not considered carefully. SGMICRO recommends that all integrated circuits be handled with appropriate precautions. Failure to observe proper handling and installation procedures can cause damage. ESD damage can range from subtle performance degradation to complete device failure. Precision integrated circuits may be more susceptible to damage because even small parametric changes could cause the device not to meet the published specifications.

RECOMMENDED OPERATING CONDITIONS

- Supply Voltage Range
 - Host Supply, V_{CCA} 1.08V to 1.98V
 - SIM Supply, V_{CCB} 1.62V to 3.6V
- Input/Output Voltage Range (Host Side)
 - CLK_HOST, $V_{I(CLK_HOST)}$ 0V to V_{CCA}
 - RST_HOST, $V_{I(RST_HOST)}$ 0V to V_{CCA}
 - IO_HOST, $V_{I(IO_HOST)}$ 0V to V_{CCA}
 - EN, $V_{I(EN)}$ 0V to 3.6V
- Input/Output Voltage Range (SIM Side)
 - CLK_SIM, $V_{I(CLK_SIM)}$ 0V to V_{CCB}
 - RST_SIM, $V_{I(RST_SIM)}$ 0V to V_{CCB}
 - IO_SIM, $V_{I(IO_SIM)}$ 0V to V_{CCB}
- Operating Temperature Range -40°C to +125°C

DISCLAIMER

SG Micro Corp reserves the right to make any change in circuit design, or specifications without prior notice.

PIN CONFIGURATION

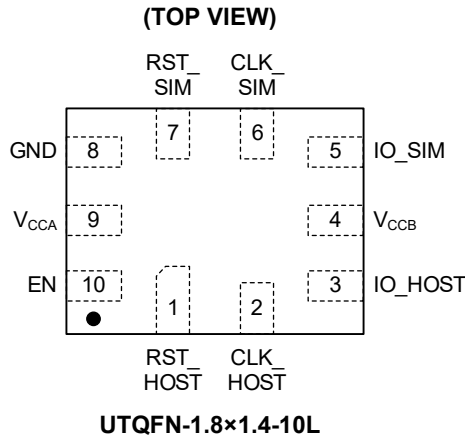

PIN DESCRIPTION

PIN	NAME	FUNCTION
1	RST_HOST	Host Controller Reset Input Pin.
2	CLK_HOST	Host Controller Clock Input Pin.
3	IO_HOST	Host Side Bidirectional Data Input/Output Pin. The output of the host must be on an open-drain driver.
4	VCCB	SIM Card Supply Voltage. When $V_{CCB} < V_{CCB_DIS}$, the chip is disabled. 100nF and 1μF ceramic capacitors should be placed as close as possible to VCCB pin.
5	IO_SIM	SIM Card Side Bidirectional Data Input/Output Pin. The output of the SIM card must be on an open-drain driver.
6	CLK_SIM	SIM Card Clock Output Pin.
7	RST_SIM	SIM Card Reset Output Pin.
8	GND	Ground Pin.
9	VCCA	Host Controller Supply Voltage for the Input/Output Pins (CLK_HOST, RST_HOST, IO_HOST, EN). 100nF and 1μF ceramic capacitors should be placed as close as possible to VCCA pin.
10	EN	Host Controller Driven Enable Pin. A logic low reduces the supply current. Connect to VCCA for normal operation.

PACKAGE OUTLINE DIMENSIONS

UTQFN-1.8x1.4-10L

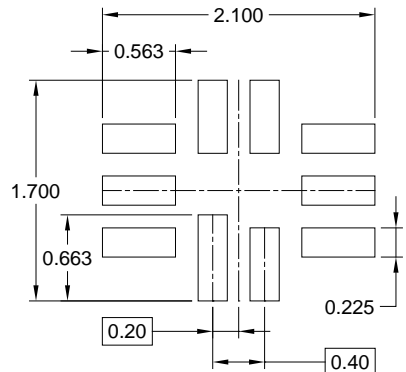
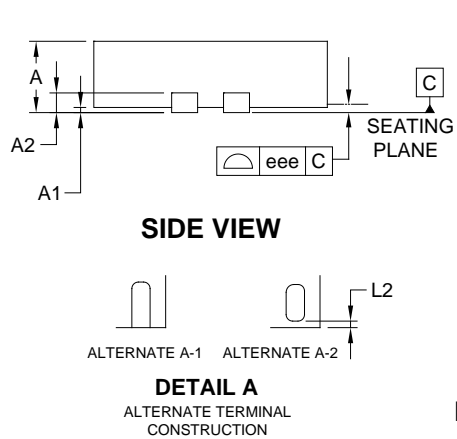
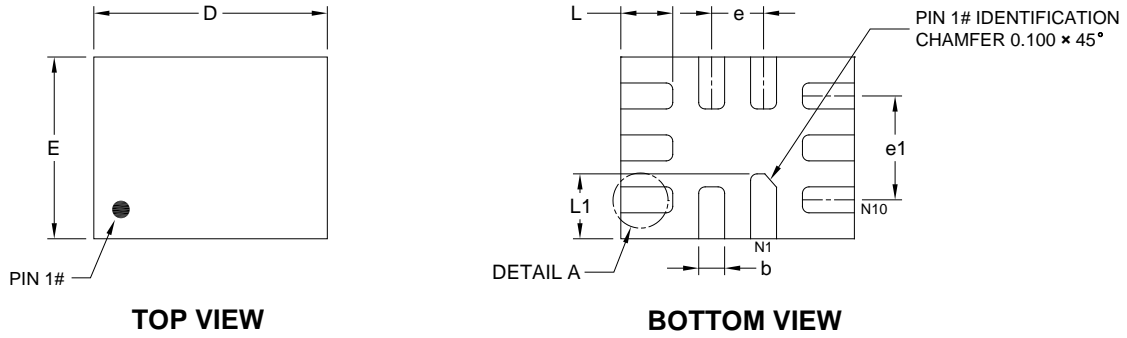

RECOMMENDED LAND PATTERN (Unit: mm)

Symbol	Dimensions In Millimeters		
	MIN	MOD	MAX
A	0.450	-	0.600
A1	0.000	-	0.050
A2	0.152 REF		
b	0.150	0.200	0.250
D	1.750	1.800	1.850
E	1.350	1.400	1.450
e	0.400 TYP		
e1	0.800 REF		
L	0.350	0.400	0.450
L1	0.450	0.500	0.550
L2	0.000	-	0.100
eee	-	0.080	-

NOTE: This drawing is subject to change without notice.

PACKAGE INFORMATION

TAPE AND REEL INFORMATION

REEL DIMENSIONS



TAPE DIMENSIONS



NOTE: The picture is only for reference. Please make the object as the standard.

KEY PARAMETER LIST OF TAPE AND REEL

Package Type	Reel Diameter	Reel Width W1 (mm)	A0 (mm)	B0 (mm)	K0 (mm)	P0 (mm)	P1 (mm)	P2 (mm)	W (mm)	Pin1 Quadrant
UTQFN-1.8×1.4-10L	7"	9.0	1.75	2.10	0.70	4.0	4.0	2.0	8.0	Q1

000001

PACKAGE INFORMATION

CARTON BOX DIMENSIONS



NOTE: The picture is only for reference. Please make the object as the standard.

KEY PARAMETER LIST OF CARTON BOX

Reel Type	Length (mm)	Width (mm)	Height (mm)	Pizza/Carton
7" (Option)	368	227	224	8
7"	442	410	224	18

DD0002