

GENERAL DESCRIPTION

The SGM41291 provides DC bias for the laser diode, EA bias, and MPD bias monitor circuits.

This chip supports I²C interface and other features such as laser diode (LD) open/short monitor, EAM short monitor, GPIO, over-temperature alert, over-temperature protection and so on.

The SGM41291 is available in a Green WLCSP-1.25×1.65-12B package.

APPLICATIONS

EML Fiber Modules
AOC and Transponders for Telecom and Data Center Interconnection

FEATURES

- Digitally Programmable EAM Bias and LD Driving Current Source
- Voltage Sources for EAM Bias (-0.2V to -4.08V, 16mV/Step) with 100mA Maximum Loading Current
- Current Sources for LD (0mA to 239.5mA, 0.5mA/Step or 0mA to 119.75mA, 0.25mA/Step)
- Backside MPD Current Monitoring (0mA to 3mA)
- Support I²C Interface and up to 1MHz I²C Clock Frequency
- LD Short/Open and EAM Short Monitoring
- +140°C Over-Temperature Alert Bit
- +165°C Over-Temperature Shutdown
- Available in a Green WLCSP-1.25×1.65-12B Package

TYPICAL APPLICATION

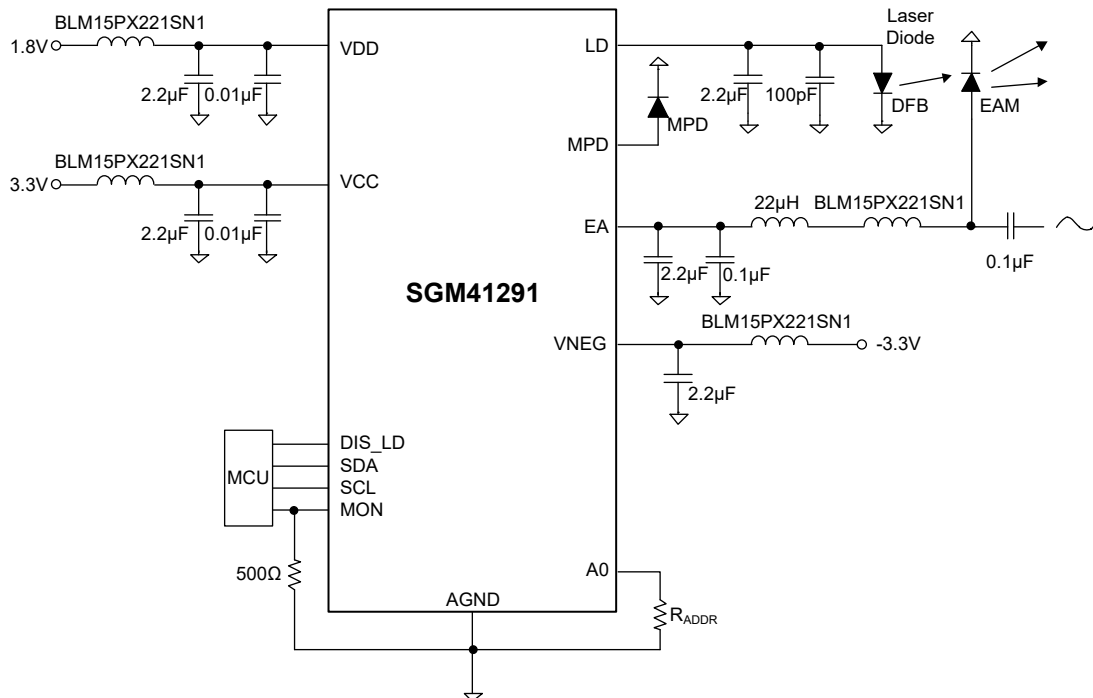

Figure 1. Typical Application Circuit

PACKAGE/ORDERING INFORMATION

MODEL	PACKAGE DESCRIPTION	SPECIFIED TEMPERATURE RANGE	ORDERING NUMBER	PACKAGE MARKING	PACKING OPTION
SGM41291	WLCSP-1.25×1.65-12B	-40°C to +125°C	SGM41291XG/TR	41291 XXXXXX XX#XX	Tape and Reel, 3000

MARKING INFORMATION

NOTE: XXXXX = Date Code, Trace Code and Vendor Code. XX#XX = Coordinate Information and Wafer ID Number.

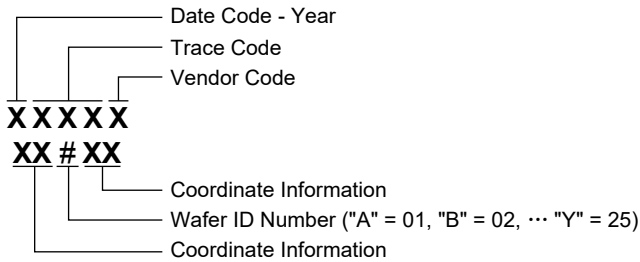

Green (RoHS & HSF): SG Micro Corp defines "Green" to mean Pb-Free (RoHS compatible) and free of halogen substances. If you have additional comments or questions, please contact your SGMICRO representative directly.

ABSOLUTE MAXIMUM RATINGS

V _{CC} , V _{DD} , SDA, SCL.....	-0.3V to 6V
V _{NEG}	-6V to 0.3V
MON, DIS_LD, A0.....	-0.3V to V _{CC} + 0.3V
MPD, V _{EA}	V _{NEG} - 0.3V to 0.3V
LD.....	-0.3V to V _{DD} + 0.3V
Typical Thermal Resistance	
WLCSP-1.25×1.65-12B, θ _{JA}	104°C/W
Junction Temperature.....	+150°C
Storage Temperature Range.....	-65°C to +150°C
Lead Temperature (Soldering, 10s).....	+260°C
ESD Susceptibility	
HBM.....	4000V
CDM.....	1000V

RECOMMENDED OPERATING CONDITIONS

V _{CC}	2.85V to 5.5V
V _{DD}	1.5V to 5.5V
V _{NEG}	-5.0V to -1.5V
MON Current Output Range.....	0mA to 3mA
MON Voltage Output Range.....	0V to 3.3V
SCL, SDA Pull-Up Voltage.....	2.5V (MIN)
Operating Ambient Temperature Range.....	-40°C to +125°C
Operating Junction Temperature Range.....	-40°C to +125°C

OVERSTRESS CAUTION

Stresses beyond those listed in Absolute Maximum Ratings may cause permanent damage to the device. Exposure to absolute maximum rating conditions for extended periods may affect reliability. Functional operation of the device at any conditions beyond those indicated in the Recommended Operating Conditions section is not implied.

ESD SENSITIVITY CAUTION

This integrated circuit can be damaged by ESD if you don't pay attention to ESD protection. SGMICRO recommends that all integrated circuits be handled with appropriate precautions. Failure to observe proper handling and installation procedures can cause damage. ESD damage can range from subtle performance degradation to complete device failure. Precision integrated circuits may be more susceptible to damage because very small parametric changes could cause the device not to meet its published specifications.

DISCLAIMER

SG Micro Corp reserves the right to make any change in circuit design, or specifications without prior notice.

PIN CONFIGURATION

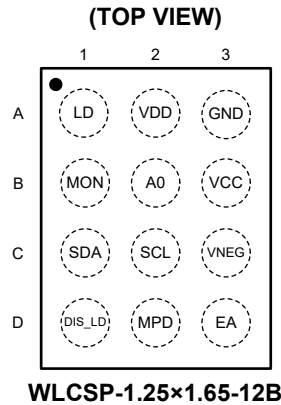

PIN DESCRIPTION

PIN	NAME	TYPE	FUNCTION
A1	LD	O	Laser Biasing Output. The current of LD is programmable via the I ² C interface.
A2	VDD	P	Power Supply for Laser Diode Current Source.
A3	GND	G	Ground.
B1	MON	O	Multiplexed Monitor Output. There are three monitor signals selected via I ² C interface.
B2	A0	O	Slave Address Programming. To program the address, a resistor is connected between this pin and ground.
B3	VCC	P	Power Supply for the Chip.
C1	SDA	I/O	Data for the I ² C Compatible Interface.
C2	SCL	I/O	Clock for the I ² C Compatible Interface.
C3	VNEG	I	Negative Power Rail Input.
D1	DIS_LD	I	Laser Bias Disable. Logic high disables the laser bias only (not EAM bias). Logic low enables the laser bias. Don't leave it floating.
D2	MPD	I	MPD Current Monitor Input. Cathode of MPD is connected to ground and anode of MPD is connected to this pin.
D3	EA	O	EAM Biasing Output. The output voltage of EA is programmable via the I ² C interface.

NOTE: I: input, O: output, I/O: input or output, G: ground, P: power for the circuit.

PACKAGE OUTLINE DIMENSIONS

WLCSP-1.25x1.65-12B

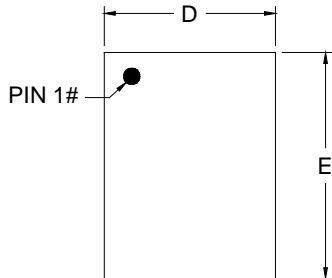

TOP VIEW

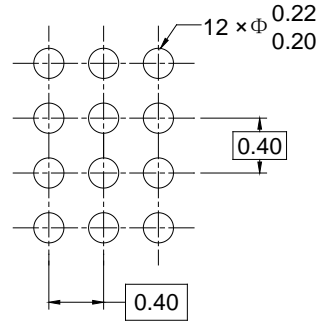

RECOMMENDED LAND PATTERN (Unit: mm)

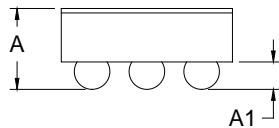

SIDE VIEW

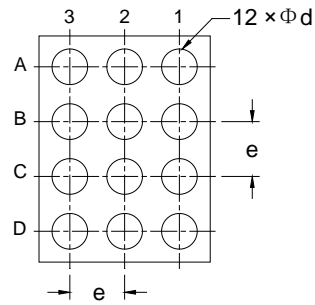

BOTTOM VIEW

Symbol	Dimensions In Millimeters		
	MIN	MOD	MAX
A	0.545	0.590	0.635
A1	0.180	0.200	0.220
D	1.220	1.250	1.280
E	1.620	1.650	1.680
d	0.240	0.260	0.280
e	0.400 BSC		

NOTE: This drawing is subject to change without notice.

PACKAGE INFORMATION

TAPE AND REEL INFORMATION

REEL DIMENSIONS



TAPE DIMENSIONS



NOTE: The picture is only for reference. Please make the object as the standard.

KEY PARAMETER LIST OF TAPE AND REEL

Package Type	Reel Diameter	Reel Width W1 (mm)	A0 (mm)	B0 (mm)	K0 (mm)	P0 (mm)	P1 (mm)	P2 (mm)	W (mm)	Pin1 Quadrant
WLCSP-1.25×1.65-12B	7"	9.5	1.38	1.78	0.78	4.0	4.0	2.0	8.0	Q1

000001

PACKAGE INFORMATION

CARTON BOX DIMENSIONS



NOTE: The picture is only for reference. Please make the object as the standard.

KEY PARAMETER LIST OF CARTON BOX

Reel Type	Length (mm)	Width (mm)	Height (mm)	Pizza/Carton
7" (Option)	368	227	224	8
7"	442	410	224	18

DD0002