

GENERAL DESCRIPTION

The SGM13003A is a low noise amplifier (LNA) for GLONASS Galileo, Beidou and GPS applications. The device delivers 17.4dB gain at an extremely low noise figure of 1.00dB. It also features high gain and excellent linearity performance that operates from 1160MHz to 1300MHz and 1550MHz to 1615MHz.

The device requires 2.2mA from a single 1.5V to 3.6V supply, dropping to below 1µA in power down mode.

No external DC blocking capacitors are required on the RF paths as long as no external DC voltage is applied, which can save PCB area and cost.

The SGM13003A is available in a Green UTDFN-1.1 ×0.7-6L package.

APPLICATIONS

- GPS Chip Module
- Personal Navigation Device (PND)
- Cell Phone with GPS
- MID/PAD with GPS

FEATURES

- **High Gain:**
 - ♦ 17.0dB at 1176.45MHz
 - ♦ 18.0dB at 1227.60MHz
 - ♦ 17.4dB at 1575.42MHz
- **Low Noise Figure:**
 - ♦ 0.96dB at 1176.45MHz
 - ♦ 0.93dB at 1227.60MHz
 - ♦ 1.00dB at 1575.42MHz
- **Low Operation Current: 2.2mA**
- **Current Less than 1µA in Power Down Mode**
- **Operating Frequency Range:**
 - ♦ 1160MHz to 1300MHz
 - ♦ 1550MHz to 1615MHz
- **Single Supply Voltage Range: 1.5V to 3.6V**
- **Low Cost BOM**
- **Lead-Free and RoHS Compliant**
- **Available in a Green UTDFN-1.1×0.7-6L Package**

BLOCK DIAGRAM

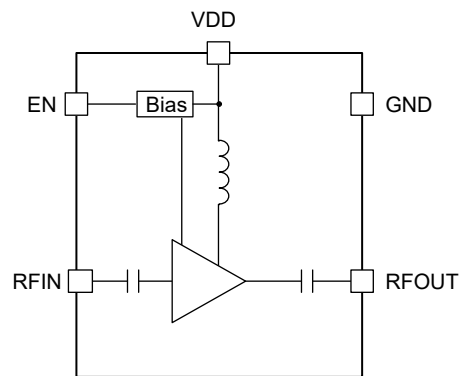

Figure 1. SGM13003A Block Diagram

PACKAGE/ORDERING INFORMATION

MODEL	PACKAGE DESCRIPTION	SPECIFIED TEMPERATURE RANGE	ORDERING NUMBER	PACKAGE MARKING	PACKING OPTION
SGM13003A	UTDFN-1.1×0.7-6L	-40°C to +85°C	SGM13003AYUEC6G/TR	00	Tape and Reel, 10000

MARKING INFORMATION

NOTE: Fixed character for 00.

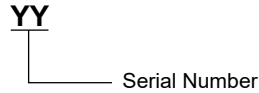

Green (RoHS & HSF): SG Micro Corp defines "Green" to mean Pb-Free (RoHS compatible) and free of halogen substances. If you have additional comments or questions, please contact your SGMICRO representative directly.

ABSOLUTE MAXIMUM RATINGS

- Supply Voltage, V_{DD} -0.3V to 4.0V
- EN to GND..... -0.3V to 4.0V
- RFIN, RFOUT to GND -0.3V to 0.3V
- RF Input Power, P_{IN} 10dBm
- Junction Temperature..... +150°C
- Storage Temperature Range -55°C to +150°C
- Lead Temperature (Soldering, 10s)..... +260°C
- ESD Susceptibility
- HBM..... 1000V
- CDM 2000V

RECOMMENDED OPERATING CONDITIONS

- Operating Temperature Range -40°C to +85°C
- Supply Voltage, V_{DD} 1.5V to 3.6V
- Operating Frequency Range,
- f_0 1160MHz to 1300MHz
- f_0' 1550MHz to 1615MHz
- Control Voltage High, V_{CTL_H} 1.35V to V_{DD}
- Control Voltage Low, V_{CTL_L} 0V to 0.45V

OVERSTRESS CAUTION

Stresses beyond those listed in Absolute Maximum Ratings may cause permanent damage to the device. Exposure to absolute maximum rating conditions for extended periods may affect reliability. Functional operation of the device at any conditions beyond those indicated in the Recommended Operating Conditions section is not implied.

ESD SENSITIVITY CAUTION

This integrated circuit can be damaged if ESD protections are not considered carefully. SGMICRO recommends that all integrated circuits be handled with appropriate precautions. Failure to observe proper handling and installation procedures can cause damage. ESD damage can range from subtle performance degradation to complete device failure. Precision integrated circuits may be more susceptible to damage because even small parametric changes could cause the device not to meet the published specifications.

DISCLAIMER

SG Micro Corp reserves the right to make any change in circuit design, or specifications without prior notice.

PIN CONFIGURATION

(TOP VIEW)

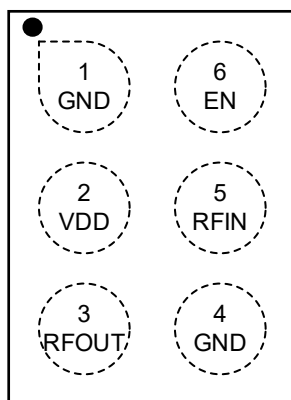

UTDFN-1.1×0.7-6L

PIN DESCRIPTION

PIN	NAME	FUNCTION
1, 4	GND	Ground.
2	VDD	Power Supply.
3	RFOUT	LNA Output.
5	RFIN	LNA Input from Antenna.
6	EN	Active High Enable Input for the Device. Pull high enable, pull low into power down mode.

PACKAGE INFORMATION

PACKAGE OUTLINE DIMENSIONS

UTDFN-1.1x0.7-6L

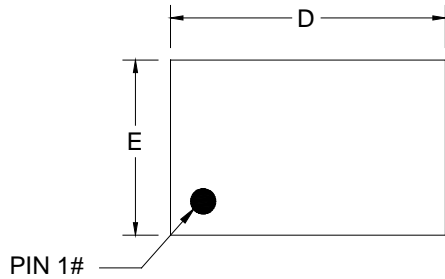

TOP VIEW

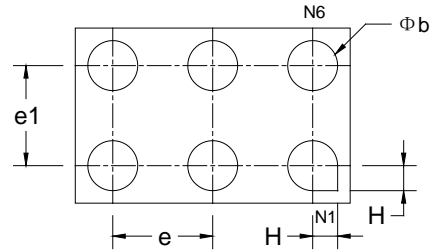

BOTTOM VIEW

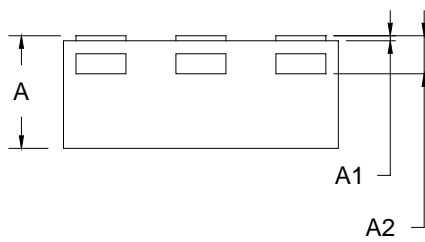

SIDE VIEW

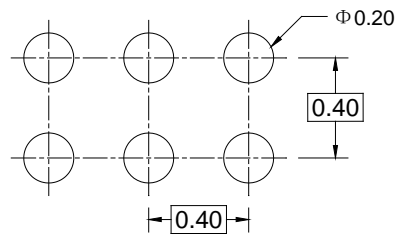

RECOMMENDED LAND PATTERN (Unit: mm)

Symbol	Dimensions In Millimeters		
	MIN	MOD	MAX
A	0.400	0.450	0.500
A1	0.000	0.020	0.050
A2	0.152 REF		
D	1.050	1.100	1.150
E	0.650	0.700	0.750
b	0.150	0.200	0.250
e	0.300	0.400	0.500
e1	0.300	0.400	0.500
H	0.100 REF		

NOTE: This drawing is subject to change without notice.

PACKAGE INFORMATION

TAPE AND REEL INFORMATION

REEL DIMENSIONS

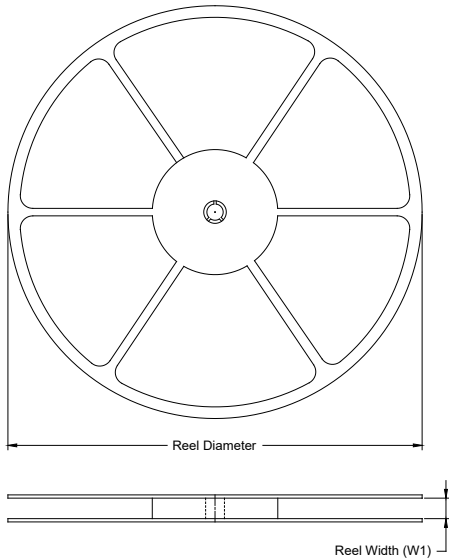

TAPE DIMENSIONS

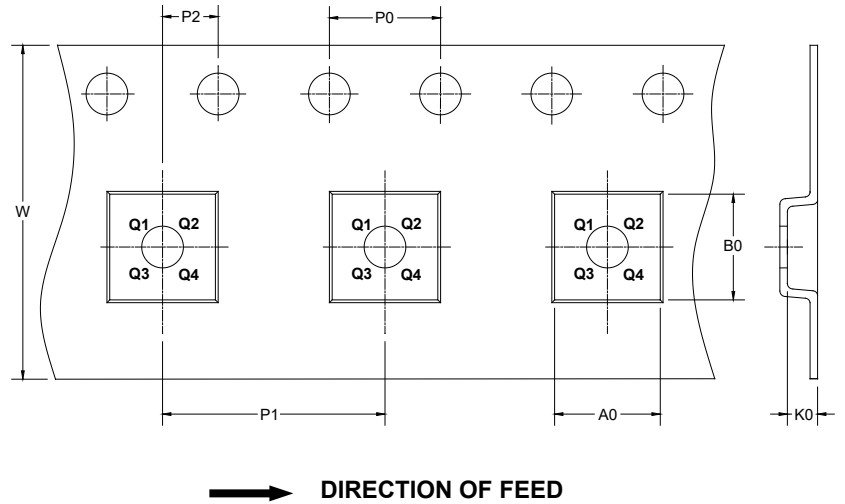

NOTE: The picture is only for reference. Please make the object as the standard.

KEY PARAMETER LIST OF TAPE AND REEL

Package Type	Reel Diameter	Reel Width W1 (mm)	A0 (mm)	B0 (mm)	K0 (mm)	P0 (mm)	P1 (mm)	P2 (mm)	W (mm)	Pin1 Quadrant
UTDFN-1.1×0.7-6L	7"	9.5	0.80	1.20	0.55	4.0	2.0	2.0	8.0	Q1

DD00001

PACKAGE INFORMATION

CARTON BOX DIMENSIONS



NOTE: The picture is only for reference. Please make the object as the standard.

KEY PARAMETER LIST OF CARTON BOX

Reel Type	Length (mm)	Width (mm)	Height (mm)	Pizza/Carton
7" (Option)	368	227	224	8
7"	442	410	224	18

DD0002