

GENERAL DESCRIPTION

The SGM823S is a complete microprocessor supervisory device which combines reset, watchdog and manual reset functions in a SOT-23-5 package. System reliability is significantly improved by such integration compared to the designs with individual ICs or discrete components. The SGM823S also features an excellent transient immunity to ignore fast V_{CC} transients.

This device has an active-low push-pull reset output (nRESET) that is activated by a logic low on the manual reset input (nMR), a watchdog expiry event or due to a low V_{CC} voltage. The nRESET output can still be in the correct logic state even if V_{CC} is 1V. The SGM823S is offered in seven fixed V_{CC} reset threshold voltages.

The SGM823S is available in a Green SOT-23-5 package. It operates over a junction temperature range of -40°C to $+125^{\circ}\text{C}$.

TYPICAL APPLICATION

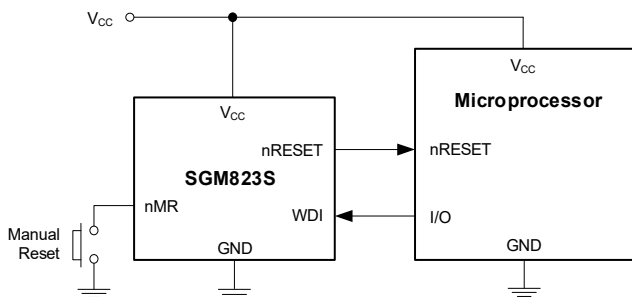

Figure 1. Typical Application Circuit Example

FEATURES

- Ultra-Low Supply Current: $0.8\mu\text{A}$ (TYP)
- Precision Supply-Voltage Monitor
 - ◆ 4.63V for SGM823S-L
 - ◆ 3.08V for SGM823S-T
 - ◆ 2.93V for SGM823S-S
 - ◆ 2.63V for SGM823S-R
 - ◆ 2.19V for SGM823S-Y
 - ◆ 1.67V for SGM823S-W
 - ◆ 1.58V for SGM823S-V
- Guaranteed nRESET Valid at $V_{CC} = 1\text{V}$
- Push-Pull nRESET Output
- Reset Pulse Width: 220ms (TYP)
- Debounced TTL/CMOS-Compatible
- Manual Reset Input
- Watchdog Timer with 1.75s (TYP) Timeout
- Fully Specified over Temperature
- Power-Supply Transient Immunity
- Without External Components
- -40°C to $+125^{\circ}\text{C}$ Operating Temperature Range
- Available in a Green SOT-23-5 Package

APPLICATIONS

- Computers
- Portable Equipment
- Automotive Equipment
- Intelligent Instruments
- Critical μP Power Monitoring

PIN CONFIGURATION

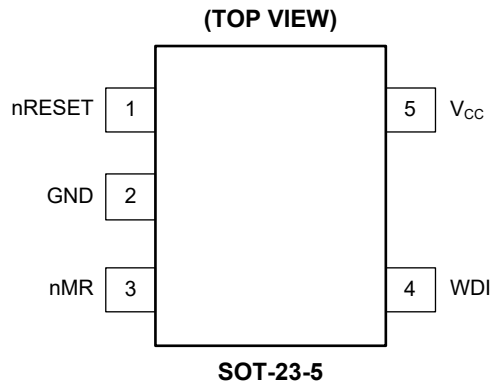

PIN DESCRIPTION

PIN	NAME	I/O	FUNCTION
1	nRESET	O	Active-Low Reset Output Pin. It delivers a 220ms (TYP) low pulse when activated. nRESET remains low if V _{CC} is below the reset threshold or nMR is logic low. It remains low for 220ms after any of the following events: V _{CC} rises above the reset threshold, a watchdog expiry triggers a reset, or the nMR input goes from low to high.
2	GND	–	Ground.
3	nMR	I	Manual Reset Input Pin. nRESET keeps low when nMR is low. When nMR is high, nRESET becomes high after a 220ms timeout period. It is an active-low reset input with an internal 60kΩ pull-up resistor. nMR can be driven by a CMOS/TTL logic or by a switch shorting to GND. If not used, leave it open or connect it to V _{CC} .
4	WDI	I	Watchdog Input Pin. If the high or low state of WDI exceeds the watchdog timeout period, the internal watchdog timer is expired and a reset is triggered. The internal watchdog timer is clear while a reset is asserted. The timer is also cleared if the WDI input is changed (on rising or falling edges). The watchdog feature is disabled if the WDI is left open or if it is connected to a three-stated buffer output.
5	V _{CC}	I	Supply Voltage Pin.

NOTE: I: input; O: output.

ELECTRICAL CHARACTERISTICS

(V_{CC} = 4.775V to 5.5V for SGM823S-L, V_{CC} = 3.175V to 5.5V for SGM823S-T, V_{CC} = 3.020V to 5.5V for SGM823S-S, V_{CC} = 2.710V to 5.5V for SGM823S-R, V_{CC} = 2.260V to 2.75V for SGM823S-Y, V_{CC} = 1.720V to 2.0V for SGM823S-W, V_{CC} = 1.630V to 5.5V for SGM823S-V, T_J = -40°C to +125°C, typical values are measured at T_J = +25°C, unless otherwise noted.)

PARAMETER	SYMBOL	CONDITIONS	MIN	TYP	MAX	UNITS	
Operating Voltage Range	V _{CC}		1		5.5	V	
VCC Absolute Current				1.12	2.19	μA	
nMR Absolute Current				0.003	0.5	μA	
WDI Absolute Current				0.018	0.5	μA	
Supply Current	I _{SUPPLY}	V _{CC} = 3.6V		0.8	1.7	μA	
		V _{CC} = 5.5V		1.00	2.00		
Reset							
nRESET Threshold	V _{nRST}	SGM823S-L	T _J = +25°C	4.505	4.63	4.755	V
			T _J = -40°C to +125°C	4.465		4.775	
		SGM823S-T	T _J = +25°C	2.995	3.08	3.165	
			T _J = -40°C to +125°C	2.955		3.175	
		SGM823S-S	T _J = +25°C	2.855	2.93	3.005	
			T _J = -40°C to +125°C	2.830		3.020	
		SGM823S-R	T _J = +25°C	2.560	2.63	2.700	
			T _J = -40°C to +125°C	2.540		2.710	
		SGM823S-Y	T _J = +25°C	2.130	2.19	2.250	
			T _J = -40°C to +125°C	2.110		2.260	
		SGM823S-W	T _J = +25°C	1.625	1.67	1.715	
			T _J = -40°C to +125°C	1.610		1.720	
		SGM823S-V	T _J = +25°C	1.535	1.58	1.625	
			T _J = -40°C to +125°C	1.520		1.630	
nRESET Threshold Hysteresis	V _{HYS}	SGM823S-L		22		mV	
		SGM823S-T		14			
		SGM823S-S		14			
		SGM823S-R		12			
		SGM823S-Y		10			
		SGM823S-W		8			
		SGM823S-V		7			
nRESET Threshold Temperature Coefficient			40	250	ppm/°C		
nRESET Pulse Width	t _{RP}		75	220	360	ms	
nRESET High-Level Output Voltage	V _{OH}	V _{CC} ≥ 3.15V, I _{SOURCE} = 500μA, reset not asserted	0.7 × V _{CC}			V	
		V _{CC} ≥ 4.75V, I _{SOURCE} = 800μA, reset not asserted	0.7 × V _{CC}				
nRESET Low-Level Output Voltage	V _{OL}	V _{CC} ≥ 1.0V, I _{SINK} = 50μA, reset asserted			0.3	V	
		V _{CC} ≥ 1.2V, I _{SINK} = 100μA, reset asserted			0.3		
		V _{CC} ≥ 2.55V, I _{SINK} = 1.2mA, reset asserted			0.3		
		V _{CC} ≥ 4.25V, I _{SINK} = 3.2mA, reset asserted			0.4		
nRESET Output Short-Circuit Current	I _{SOURCE}	nRESET = 0V, V _{CC} = 5.5V		24	32	mA	
V _{CC} to Reset Delay	t _{RD}	V _{nRST} - V _{CC} = 500mV		12		μs	

ELECTRICAL CHARACTERISTICS (continued)

($V_{CC} = 4.775V$ to $5.5V$ for SGM823S-L, $V_{CC} = 3.175V$ to $5.5V$ for SGM823S-T, $V_{CC} = 3.020V$ to $5.5V$ for SGM823S-S, $V_{CC} = 2.710V$ to $5.5V$ for SGM823S-R, $V_{CC} = 2.260V$ to $2.75V$ for SGM823S-Y, $V_{CC} = 1.720V$ to $2.0V$ for SGM823S-W, $V_{CC} = 1.630V$ to $5.5V$ for SGM823S-V, $T_J = -40^{\circ}C$ to $+125^{\circ}C$, typical values are at $T_J = +25^{\circ}C$, unless otherwise noted.)

PARAMETER	SYMBOL	CONDITIONS	MIN	TYP	MAX	UNITS
Watchdog						
Watchdog Timeout Period	t_{WD}		0.6	1.75	2.9	s
WDI Pulse Width	t_{WP}	$V_{IL} = 0V, V_{IH} = V_{CC}$	90			ns
WDI Low-Level Input Voltage	V_{IL_WDI}	$V_{nRST_MAX} < V_{CC} < 5V$			0.6	V
WDI High-Level Input Voltage	V_{IH_WDI}	$V_{nRST_MAX} < V_{CC} < 5V$	$0.7 \times V_{CC}$			V
WDI Input Current		WDI = V_{CC}		0.003	0.5	μA
		WDI = 0V	-0.5	-0.004		
Manuel Reset						
nMR Low-Level Input Voltage	V_{IL_nMR}				0.6	V
nMR High-Level Input Voltage	V_{IH_nMR}		2			V
nMR Pulse Width	t_{MR}		400			ns
nMR Noise Immunity (Pulse Width with No Reset)				200		ns
nMR to nRESET Out Delay	t_{MD}				470	ns
nMR Pull-Up Resistance (Internal)		$V_{CC} = 5V$	20	60	100	k Ω

TYPICAL PERFORMANCE CHARACTERISTICS

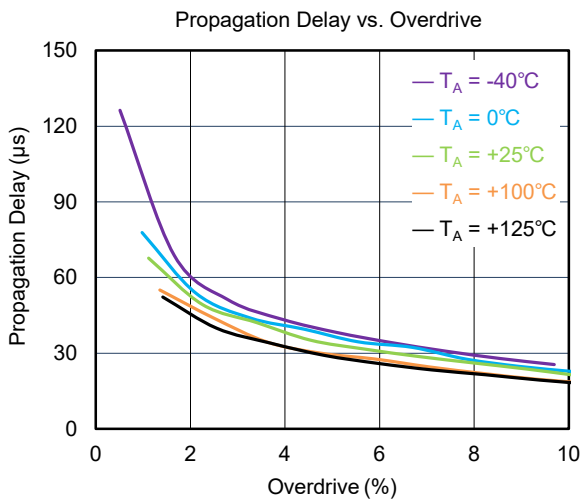
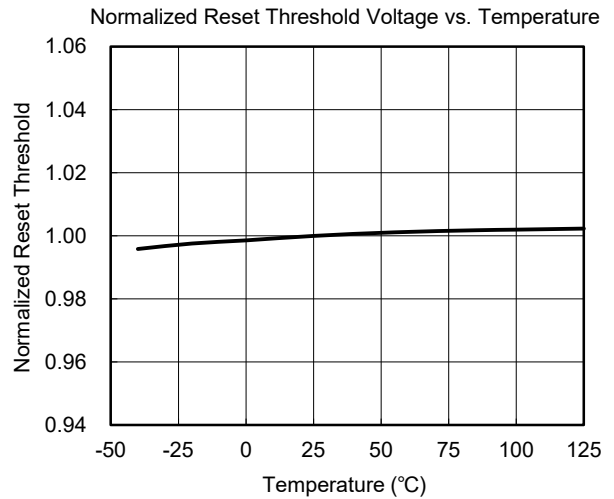
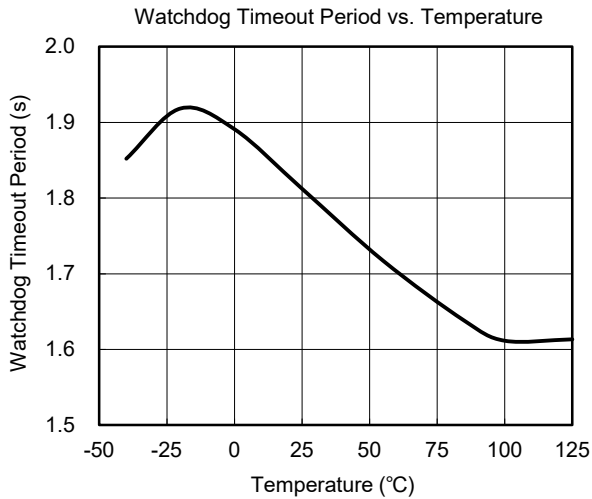
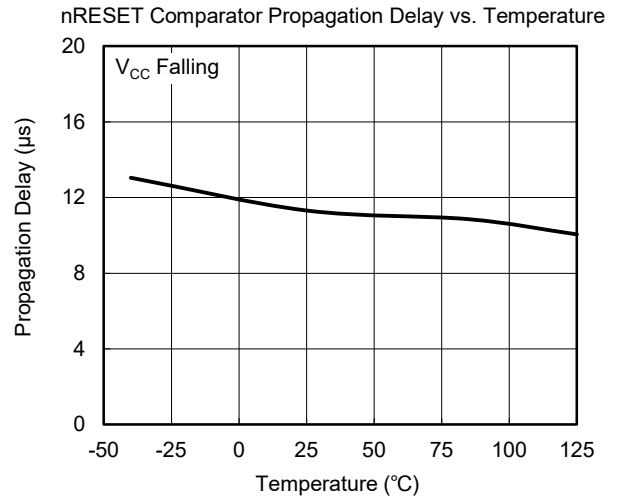
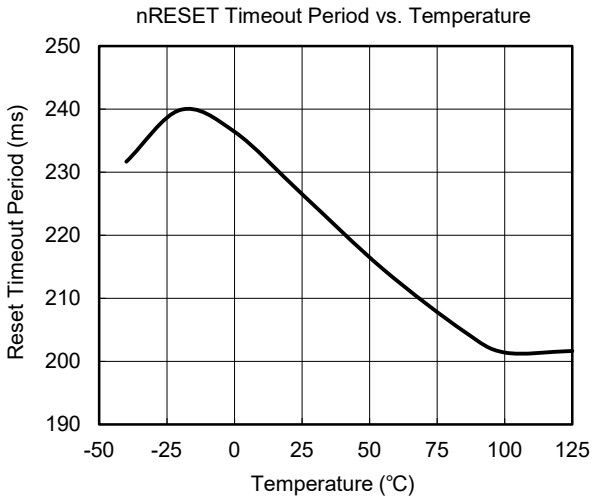

FUNCTIONAL BLOCK DIAGRAM

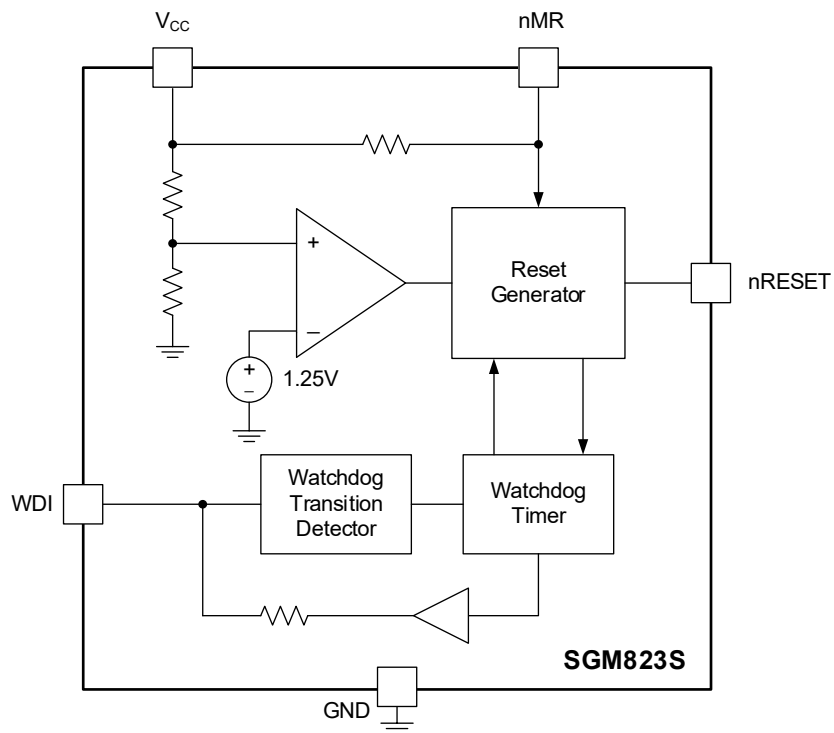

Figure 2. Block Diagram

DETAILED DESCRIPTION

nRESET Output

The reset input of a microprocessor (μP) initiates it to a known state. The SGM823S supervisory circuit asserts a reset to the supervised μP to prevent the code-execution errors that may occur due to power-up, power-down, brownout conditions or other transients. The nRESET output is still in the correct logic state even if V_{CC} is lower than 1V. During power-up, when V_{CC} exceeds the rising threshold voltage ($V_{nRST} + V_{HYS}$), an internal timer keeps nRESET in low state for the reset timeout period (t_{RP}) before nRESET returns to the high state (Figure 3).

If V_{CC} drops below the falling threshold voltage (V_{nRST}) (a brownout condition occurs), a reset is asserted and nRESET goes low. In general, nRESET remains low for the t_{RP} (220ms, TYP) period every time after the last event. So, if during the low period of nRESET, V_{CC} goes up and dips below V_{nRST} again, the internal timer will restart for a new t_{RP} period. The nRESET output can source and sink current.

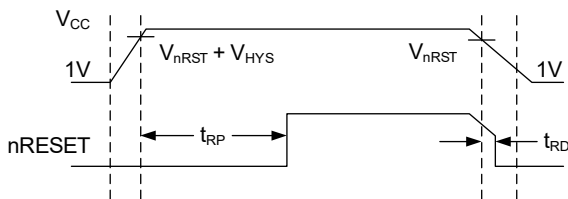

Figure 3. nRESET Timing Diagram

Manual Reset Input

Many μP -based products need manual-reset capability to let the operator or an external logic reset the μP . For the SGM823S, applying a logic low to the nMR input, asserts a reset (nRESET = low). nRESET remains low while nMR is low, and will stay low for the t_{RP} (220ms, TYP) period after nMR returns to high state. The nMR input is internally pulled up by a 60k Ω resistor and can be left floating if not used. It can be driven by a CMOS/TTL logic or by a switch shorting to GND. A normally open momentary switch connected between nMR and GND pins can be used as a manual reset. Switch debouncing is not needed. However, if long cables are used to drive the nMR input or if the environment is noisy, connect a 0.1 μF capacitor between nMR and GND to immune the additional noise.

Watchdog Input

The internal watchdog circuit monitors the μP 's activity by checking the WDI input. If the μP does not toggle the WDI within the watchdog t_{WD} (1.75s, TYP) period, nRESET will send a low pulse to reset the μP . So, the code should be written such that successive toggles on WDI occur in periods not longer than the lowest t_{WD} time to reset the internal watchdog timer and prevent μP reset when the code is running normally. The watchdog timer is cleared by either toggling WDI or by a pulse with a duration as short as 90ns. While the reset is asserted and nRESET is low, the watchdog timer is cleared and timer does not count. It starts counting when the reset is released and nRESET goes high (Figure 4).

To disable the watchdog function, leave the WDI pin open. If WDI is driven by a 3-state buffer, set it to the Hi-Z state. In this case the buffer leakage current should not exceed 10 μA . The maximum capacitance seen on the WDI pin should be less than 200pF to assure that watchdog remains disabled. The watchdog input is internally oscillating when it is left open to clear the watchdog timer and prevent it from generating a reset. It is driven low during the first 7/8 of the watchdog timeout period and driven high in the last 1/8 of that. For example if WDI input is open and the watchdog timeout is 1.75s, the watchdog timer will automatically clear every 1.53s and reset will not occur.

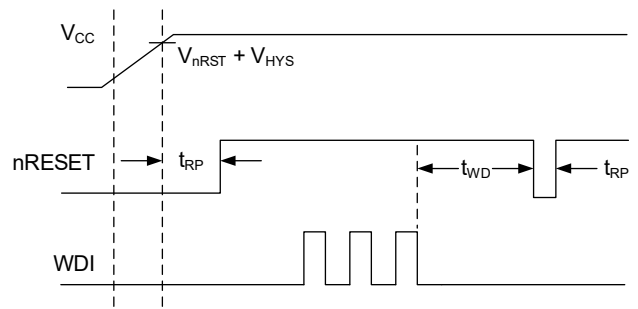

Figure 4. Watchdog Timing Relationship

APPLICATION INFORMATION

Using SGM823S with Microprocessors with Bidirectional Reset Pins

Some microprocessors can internally force their reset pins low to assert a reset (bidirectional reset pins). The low pull-up current of the SGM823S allows using of them along with the microprocessors with bidirectional resets like the 68HC11. The microprocessor can force nRESET low when nRESET is pulled high by the SGM823S with no issues (Figure 5).

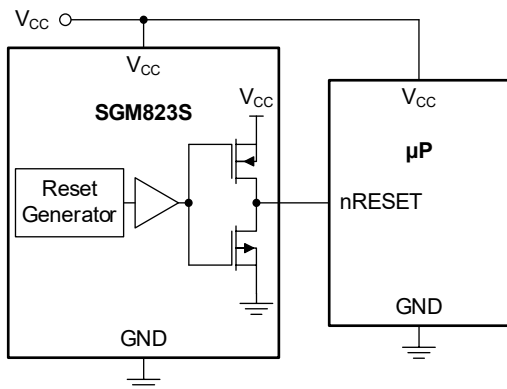

Figure 5. Interfacing to µP with Bidirectional Resets

Negative-Going V_{CC} Transient Immunity

The SGM823S has the ability to immune short time and negative V_{CC} transients or even glitches. It does not need to shut down the entire system. Resets are applied to the microprocessor during power-up, power-down and brownout conditions and not when an insignificant V_{CC} transient occurs.

A 0.1µF ceramic capacitor is recommended between the V_{CC} and GND pin to reduce the input supply noise.

Watchdog Input Current

The WDI input is internally driven by a buffer and series resistor from an internal counter chain stage of the watchdog. Therefore, when WDI is open, the watchdog timer is automatically cleared before timeout (by an internal low-high-low pulse).

To get the minimum WDI input current (minimum power loss), keep WDI low for the majority of the timeout period and send a high pulse at the first 7/8 of the timeout period for clearing the watchdog timer.

Watchdog Software Considerations

To have a more effective watchdog in software monitoring, rather than generating pulses by a code segment, set and reset the WDI input at different points of the program code. For example, set it in the main program and reset it in a periodic timing interrupt. For example if WDI is toggled within an unwanted infinite loop, it will continuously reset watchdog as a normal condition and the processor is not reset.

An example of a watchdog flow is shown in Figure 6. The WDI is set high at the start of the program, and is set low at the start of every subroutine or loop, then is set high again when the program returns to the start. If the processor hangs in any subroutine, the WDI toggling will not occur and the watchdog will reset the processor and correct the situation.

The nRESET output may also be connected to an interrupt input of the µP for a corrective action if preferred.

Note that such watchdog control schemes may not be optimal if the total power consumption is critical as discussed in the watchdog input current section.

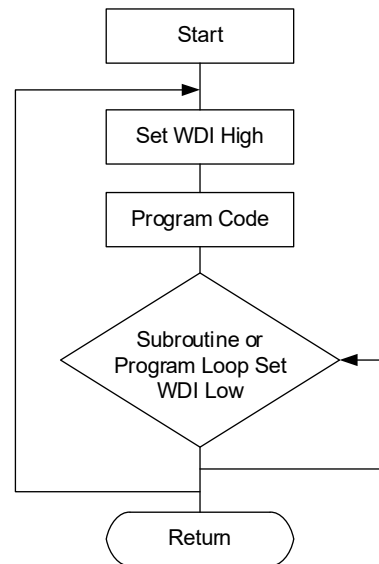

Figure 6. Watchdog Flow Diagram

REVISION HISTORY

NOTE: Page numbers for previous revisions may differ from page numbers in the current version.

OCTOBER 2023 – REV.A to REV.A.1	Page
Updated Package/Ordering Information section.....	2
Changed Electrical Characteristics section	4, 5

Changes from Original (AUGUST 2023) to REV.A	Page
Changed from product preview to production data.....	All

PACKAGE INFORMATION

PACKAGE OUTLINE DIMENSIONS

SOT-23-5

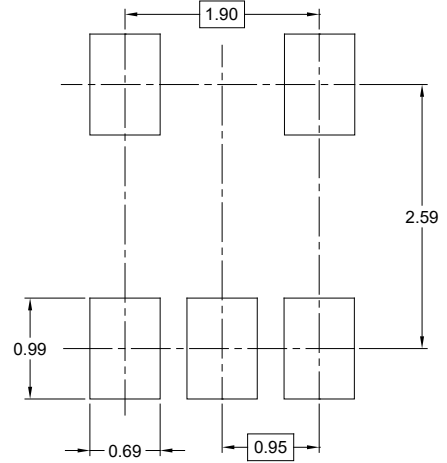
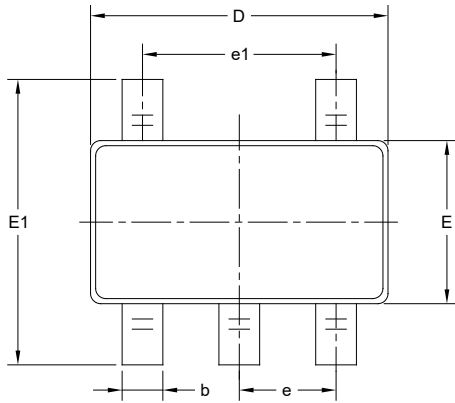

RECOMMENDED LAND PATTERN (Unit: mm)

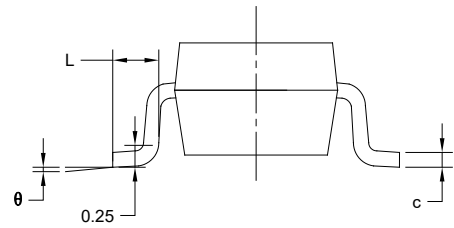
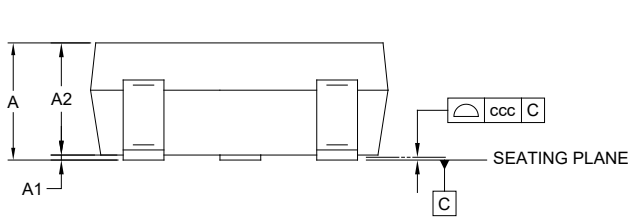

Symbol	Dimensions In Millimeters		
	MIN	MOD	MAX
A	-	-	1.450
A1	0.000	-	0.150
A2	0.900	-	1.300
b	0.300	-	0.500
c	0.080	-	0.220
D	2.750	-	3.050
E	1.450	-	1.750
E1	2.600	-	3.000
e	0.950 BSC		
e1	1.900 BSC		
L	0.300	-	0.600
θ	0°	-	8°
ccc	0.100		

NOTES:

1. This drawing is subject to change without notice.
2. The dimensions do not include mold flashes, protrusions or gate burrs.
3. Reference JEDEC MO-178.

PACKAGE INFORMATION

TAPE AND REEL INFORMATION

REEL DIMENSIONS

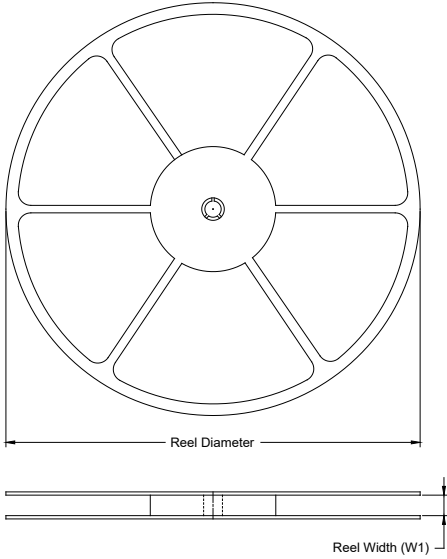

TAPE DIMENSIONS



NOTE: The picture is only for reference. Please make the object as the standard.

KEY PARAMETER LIST OF TAPE AND REEL

Package Type	Reel Diameter	Reel Width W1 (mm)	A0 (mm)	B0 (mm)	K0 (mm)	P0 (mm)	P1 (mm)	P2 (mm)	W (mm)	Pin1 Quadrant
SOT-23-5	7"	9.5	3.20	3.20	1.40	4.0	4.0	2.0	8.0	Q3

000001

PACKAGE INFORMATION

CARTON BOX DIMENSIONS



NOTE: The picture is only for reference. Please make the object as the standard.

KEY PARAMETER LIST OF CARTON BOX

Reel Type	Length (mm)	Width (mm)	Height (mm)	Pizza/Carton
7" (Option)	368	227	224	8
7"	442	410	224	18

DD0002